



1-2-3 KVC AD

DOMESTIC CONSTANT PRESSURE BOOSTER SETS
WITH ACTIVE DRIVER



1-2-3 KVC AD

DOMESTIC CONSTANT PRESSURE BOOSTER SETS WITH ACTIVE DRIVER



TECHNICAL DATA

Operating range: from 0,5 to 36 m³/h.

Pumped liquid: clean, free of solids and abrasives, non viscous, non aggressive, non crystallised and chemically neutral, with properties similar to water.

Pumped liquid temperature range: from 0 °C to +40 °C

Maximum ambient temperature: +40 °C.

Maximum operating pressure: PN12.

Special executions on request: up to 4 pumps

Protection class: IP44.

All the domestic units with Active Driver Plus have 1 8-litre expansion vessel and delivery and suction manifolds in AISI 304 stainless steel.



APPLICATIONS

1-2-3 KVC A.D. are **variable speed** pressurization sets with 1, 2 or 3 vertical multistage centrifugal pumps particularly suited for domestic use and small civil or industrial use systems. Thanks to the use of the Active Driver Plus inverter, they ensure performance levels capable of automatically adapting to the different system requirements, meeting the need for constant pressure of the modern system technology. The constant pressure adjustment is a requirement in the most varied sectors: Water pipelines, Irrigation, Industry, Hotel, Residential building, Spas.

Their main features are reliability, simple operation, and minimum maintenance requirements.

CONSTRUCTION FEATURES

HYDRAULIC SECTION

1 to 3 KVC vertical multistage electric pumps (version with up to 4 pumps available on request)

Galvanized sheet steel base complete with 4 rubber anti-vibration feet.

Suction and delivery manifolds in stainless steel.

1 x 8-litre expansion vessel per set (18 litres for the 85/120 size)

Check valves both at the suction and the delivery and non-return valve at the delivery included

ELECTRICAL SECTION

1 to 3 Active Driver Plus inverters on the delivery of each pump

1 protection control unit for 2 and 3 pump sets

MULTI INVERTER SYSTEM WITH ACTIVE DRIVER

The inverter provides constant control of the rotation speed of the electric pump, ensuring constant pressure despite flow rate variations.

The other electric pumps, also with variable speed, are activated in cascade after the first one has reached maximum speed. Through modulation, they compensate the pressure fluctuations of the system.

For every operating cycle, it is possible to switch the restart to a different pump, therefore ensuring even use of all electric pumps.

It is possible to set operation times for each individual pump, switching to another pump after such set times.

The „SP“ pressure can be adjusted by the user using two „+“ and „-“ keys on the A.D. (as a rule, all the pumps are set to the same pressure value).

MATERIALS

N°	PARTS*	MATERIALS
1	PUMP BODY	TECHNOPOLYMER A
4	IMPELLER	TECHNOPOLYMER B
6	DIFFUSER	TECHNOPOLYMER B
7	SHAFT WITH ROTOR	AISI 303 STAINLESS STEEL X10 CrNi 1089 UNI 6900/71
16	MECHANICAL SEAL	SILICON CARBIDE/SILICON
28	OR RING	EPDM RUBBER
36	SEAL HOLDING DISC	AISI 304 STAINLESS STEEL X5 CrNi 1810 UNI 6900/71
57a	INTERMEDIATE STAGE	TECHNOPOLYMER B
69	LINER	AISI 304 STAINLESS STEEL X5 CrNi 1810 UNI 6900/71
98	DIFFUSER BODY	TECHNOPOLYMER B
271	CENTERING BUSHING	BRONZE B14
304	CONVEYOR	TECHNOPOLYMER B
8	DNM (standard for KVCX only)	

* In contact with the liquid.

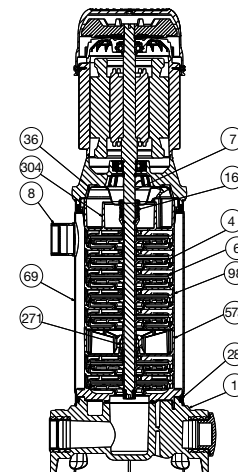

1-2-3 KVC AD

DOMESTIC CONSTANT PRESSURE BOOSTER SETS WITH ACTIVE DRIVER

PERFORMANCE RANGE

The performance curves are based on kinematic viscosity values = 1 mm²/s and density equal to 1000 kg/m³. Curve tolerance according to ISO 9906.

GRAPHIC SELECTION TABLE

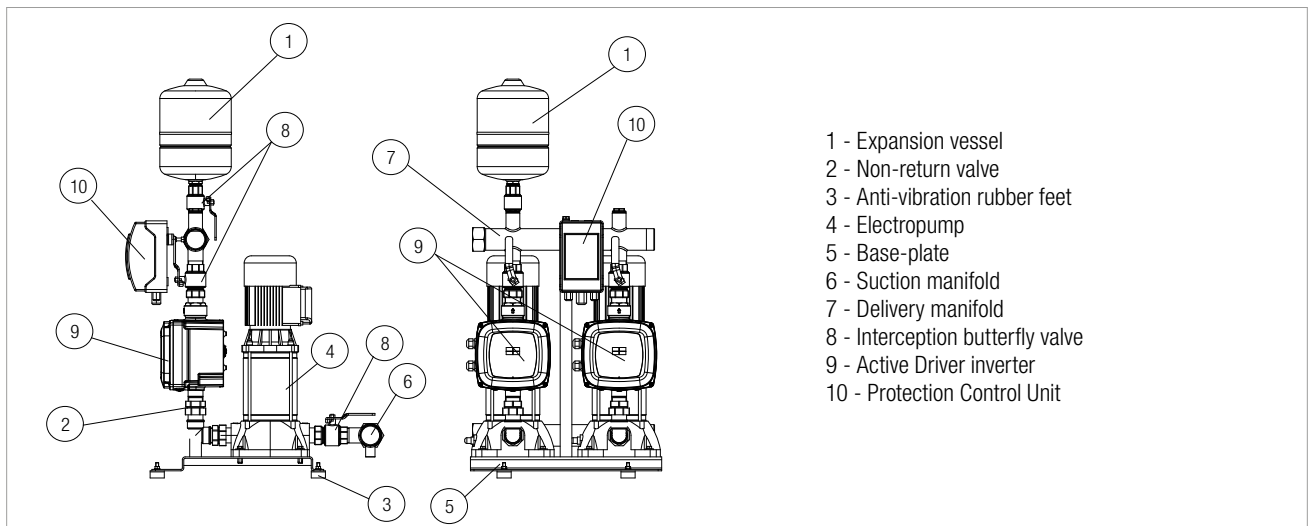
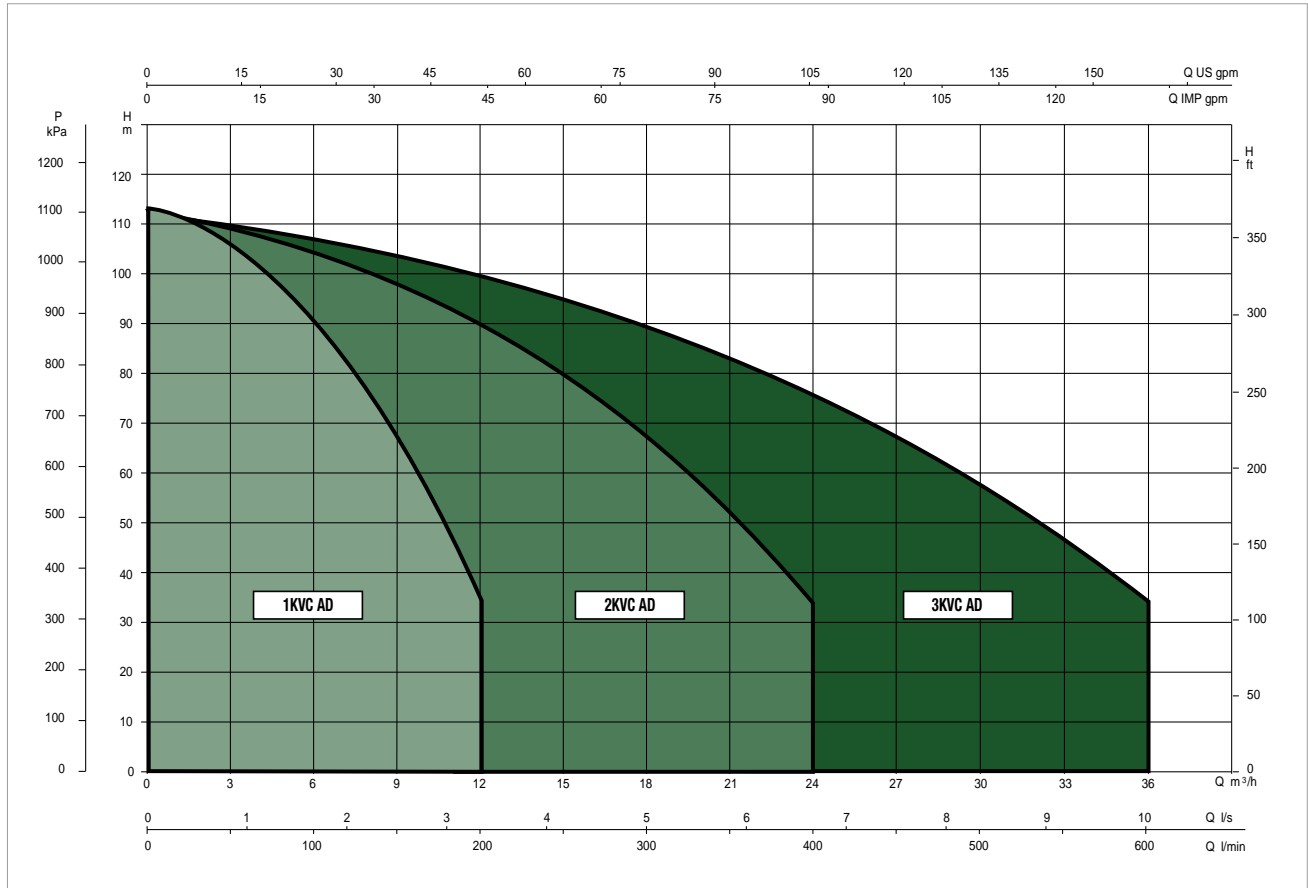

1 KVC AD - DOMESTIC PRESSURE BOOSTER SETS

Pumped liquid temperature range: from 0°C to +35°C (for domestic use) / from 0°C to +40°C (for other uses)

Maximum ambient temperature: +40°C - Max flow rate: 12 m³/h

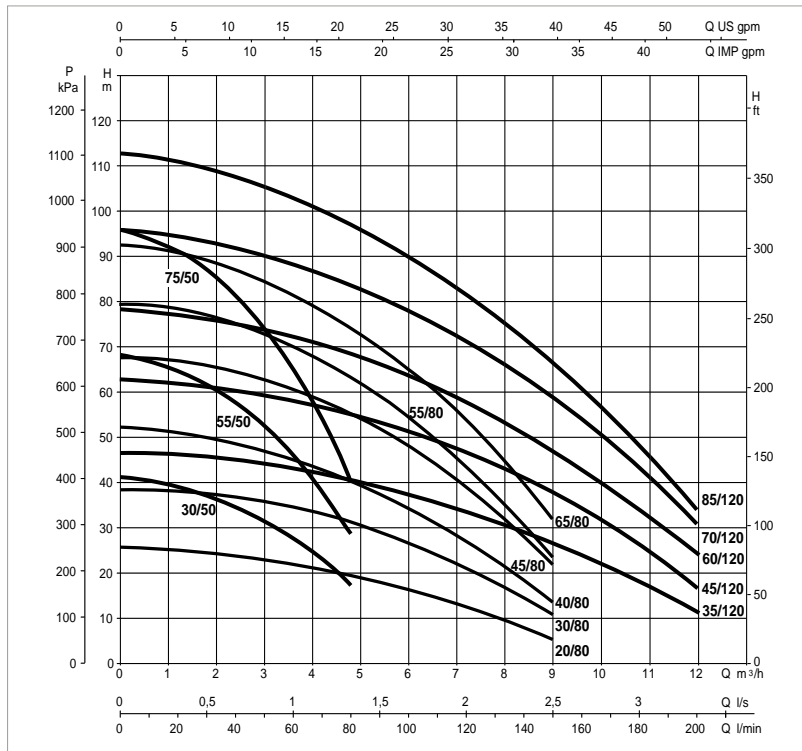
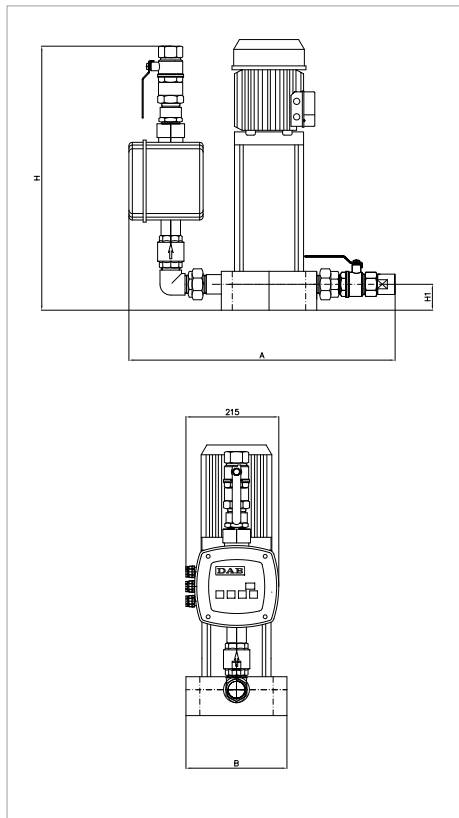

The performance curves are based on kinematic viscosity values = 1 mm²/s and density equivalent to 1000 kg/m³

Curve tolerance according to ISO 9906.

The performance results of sets with smaller pumps (e.g. KVC AD 30/50) are obtained through simple calibration of the AD module

MODEL	POWER INPUT 50 Hz	P2 NOMINAL		In (set) A	ACTIVE DRIVER PLUS MODEL	FLOW m ³ /h	MAX PRESSURE BAR	STANDARD PRESSURE BAR
		KW	HP					
1 KVC AD 30/50	1x220-240 V~	0,55	0,75	4,1	MT 1,0	0,5 - 4,8	4,0	3,5
1 KVC AD 55/50	1x220-240 V~	1	1,36	7,6	MT 1,0	0,5 - 4,8	6,5	5,5
1 KVC AD 75/50	1x220-240 V~	1,5	2	10,7	MT 2,2	0,5 - 4,8	9,5	8,0
1 KVC AD 20/80	1x220-240V ~	0,55	0,75	4,8	MT 1,0	0,7 - 9,0	2,5	2,0
1 KVC AD 30/80	1x220-240 V~	0,9	1,2	6,5	MT 1,0	0,7 - 9,0	4,0	3,5
1 KVC AD 40/80	1x220-240 V~	1,1	1,5	7,7	MT 1,0	0,7 - 9,0	5,0	4,5
1 KVC AD 45/80	1x220-240 V~	1,5	2	9,6	MT 2,2	0,7 - 9,0	6,5	5,5
1 KVC AD 55/80	1x220-240 V~	1,85	2,5	11,2	MT 2,2	0,7 - 9,0	8,0	7,5
1 KVC AD 65/80	1x220-240 V~	2,2	3	12	MT 2,2	0,7 - 9,0	9,0	8,0
1 KVC AD 35/120	1x220-240 V~	1,1	1,5	10,4	MT 2,2	1,2 - 12	4,5	3,5
1 KVC AD 45/120	1x220-240 V~	1,85	2,50	13,6	MT 2,2	1,2 - 12	6,0	5,0
1 KVC AD 60/120	3x400 V~	2,2	3	5,4	T/T 3,0	1,2 - 12	7,5	6,5
1 KVC AD 70/120	3x400 V~	3	4	6,8	T/T 3,0	1,2 - 12	9,5	7,5
1 KVC AD 85/120	3x400 V~	3	4	7,8	T/T 5,5	1,2 - 12	11,0	8,5

MODEL	A	B	H	H1	DNA	DNM	PACKING DIMENSIONS			VOLUME m ³	WEIGHT kg
							L/A	L/B	H		
1 KVC AD 30/50	530	250	620	60	1" 1/4	1" 1/4	850	610	1000	0,52	32
1 KVC AD 55/50	530	250	620	60	1" 1/4	1" 1/4	850	610	1000	0,52	35
1 KVC AD 75/50	530	250	620	60	1" 1/4	1" 1/4	850	610	1000	0,52	39
1 KVC AD 20/80	530	250	620	60	1" 1/4	1" 1/4	850	610	1000	0,52	32
1 KVC AD 30/80	530	250	620	60	1" 1/4	1" 1/4	850	610	1000	0,52	34
1 KVC AD 40/80	530	250	620	60	1" 1/4	1" 1/4	850	610	1000	0,52	36
1 KVC AD 45/80	530	250	620	60	1" 1/4	1" 1/4	850	610	1000	0,52	38
1 KVC AD 55/80	530	250	620	60	1" 1/4	1" 1/4	850	610	1000	0,52	39
1 KVC AD 65/80	530	250	620	60	1" 1/4	1" 1/4	850	610	1000	0,52	40
1 KVC AD 35/120	530	250	620	60	1" 1/4	1" 1/4	850	610	1000	0,52	34
1 KVC AD 45/120	530	250	620	60	1" 1/4	1" 1/4	850	610	1000	0,52	37
1 KVC AD 60/120	530	250	620	60	1" 1/4	1" 1/4	850	610	1000	0,52	39
1 KVC AD 70/120	530	250	620	60	1" 1/4	1" 1/4	850	610	1000	0,52	40
1 KVC AD 85/120	530	250	620	60	1" 1/4	1" 1/4	850	610	1000	0,52	42

I gruppi vengono forniti completi di un robusto imballo di cartone con paletta di legno e libretto istruzioni di installazione / manutenzione.

2 KVC AD - DOMESTIC PRESSURE BOOSTER SETS

Pumped liquid temperature range: from 0°C to +35°C (for domestic use) / from 0°C to +40°C (for other uses)

Maximum ambient temperature: +40°C - Max flow rate: 24 m³/h

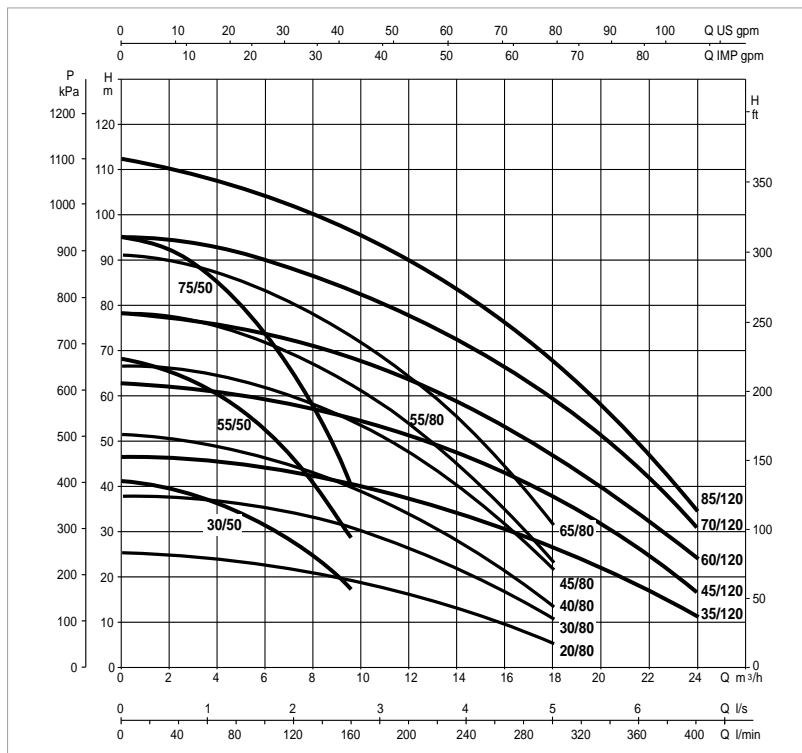
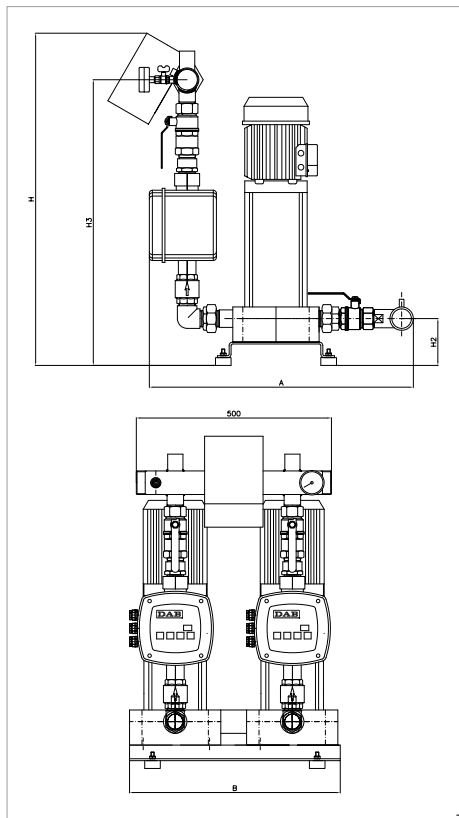

The performance curves are based on kinematic viscosity values = 1 mm²/s and density equivalent to 1000 kg/m³
 Curve tolerance according to ISO 9906. **Overall performance taking into account TWO pumps working at the same time.**
 The performance results of sets with smaller pumps (e.g. 2 KVC 20/50) are obtained through simple calibration of the AD module

MODEL	POWER INPUT 50 Hz	P2 NOMINAL		In (set) A	ACTIVE DRIVER PLUS MODEL	FLOW m ³ /h	MAX PRESSURE BAR	STANDARD PRESSURE BAR
		KW	HP					
2 KVC AD 30/50	1x220-240 V~	2x0,55	2x0,75	2 x 4,1	M/T 1,0	0,5 - 9,6	4,0	3,5
2 KVC AD 55/50	1x220-240 V~	2x1	2x1,36	2 x 7,6	M/T 1,0	0,5 - 9,6	6,5	5,5
2 KVC AD 75/50	3x400 V~ + N *	2x1,5	2x2	2 x 10,7	M/T 2,2	0,5 - 9,6	9,5	8,0
2 KVC AD 20/80	1x220-240V ~	2x0,55	2x0,75	2 x 4,8	M/T 1,0	0,7 - 18,0	2,5	2,0
2 KVC AD 30/80	1x220-240 V~	2x0,9	2x1,2	2 x 6,5	M/T 1,0	0,7 - 18,0	4,0	3,5
2 KVC AD 40/80	1x220-240 V~	2x1,1	2x1,5	2 x 7,7	M/T 1,0	0,7 - 18,0	5,0	4,5
2 KVC AD 45/80	1x220-240 V~	2x1,5	2x2	2 x 9,6	M/T 2,2	0,7 - 18,0	6,5	5,5
2 KVC AD 55/80	1x220-240 V~	2x 1,85	2x2,5	2 x 11,2	M/T2,2	0,7 - 18,0	8,0	7,5
2 KVC AD 65/80	3x400 V~ + N *	2x2,2	2x3	2 x 12,0	M/T 2,2	0,7 - 18,0	9,0	8,0
2 KVC AD 35/120	1x220-240V~	2x1,1	2x1,5	2 x 10,4	M/T 2,2	1,2 - 24	4,5	3,5
2 KVC AD 45/120	1x220-240 V~	2x1,85	2x2,50	2 x 13,6	M/T 2,2	1,2 - 24	6,0	5,0
2 KVC AD 60/120	3x400 V~	2x2,2	2x3	2 x 5,4	T/T 3,0	1,2 - 24	7,5	6,5
2 KVC AD 70/120	3x400 V~	2x3,0	2x4	2 x 6,8	T/T 3,0	1,2 - 24	9,5	7,5
2 KVC AD 85/120	3x400 V~	2x3,0	2x4	2 x 7,8	T/T 5,5	1,2 - 24	11,0	8,5

* Single phase power input also available on request (1x220-240 V~).

MODEL	A	B	H	H2	H3	DNA	DNM	PACKING DIMENSIONS			VOLUME m ³	WEIGHT kg
								L/A	L/B	H		
2 KVC AD 30/50	660	550	830	100	710	2"	2"	1000	610	1000	0,61	76
2 KVC AD 55/50	660	550	830	100	710	2"	2"	1000	610	1000	0,61	83
2 KVC AD 75/50	660	550	830	100	710	2"	2"	1000	610	1000	0,61	91
2 KVC AD 20/80	660	550	830	100	710	2"	2"	1000	610	1000	0,61	78
2 KVC AD 30/80	660	550	830	100	710	2"	2"	1000	610	1000	0,61	80
2 KVC AD 40/80	660	550	830	100	710	2"	2"	1000	610	1000	0,61	85
2 KVC AD 45/80	660	550	830	100	710	2"	2"	1000	610	1000	0,61	89
2 KVC AD 55/80	660	550	830	100	710	2"	2"	1000	610	1000	0,61	90
2 KVC AD 65/80	660	550	830	100	710	2"	2"	1000	610	1000	0,61	93
2 KVC AD 35/120	660	550	830	100	710	2"	2"	1000	610	1000	0,61	81
2 KVC AD 45/120	660	550	830	100	710	2"	2"	1000	610	1000	0,61	83
2 KVC AD 60/120	660	550	830	100	710	2"	2"	1000	610	1000	0,61	89
2 KVC AD 70/120	660	550	830	100	710	2"	2"	1000	610	1000	0,61	95
2 KVC AD 85/120	660	550	830	100	710	2"	2"	1000	610	1000	0,61	97

The sets are supplied in a sturdy cardboard packaging on wooden pallet and installation / maintenance manual.

3 KVC AD - DOMESTIC PRESSURE BOOSTER SETS

Pumped liquid temperature range: from 0°C to +35°C (for domestic use) / from 0°C to +40°C (for other uses)

Maximum ambient temperature: +40°C - Max flow rate: 36 m³/h

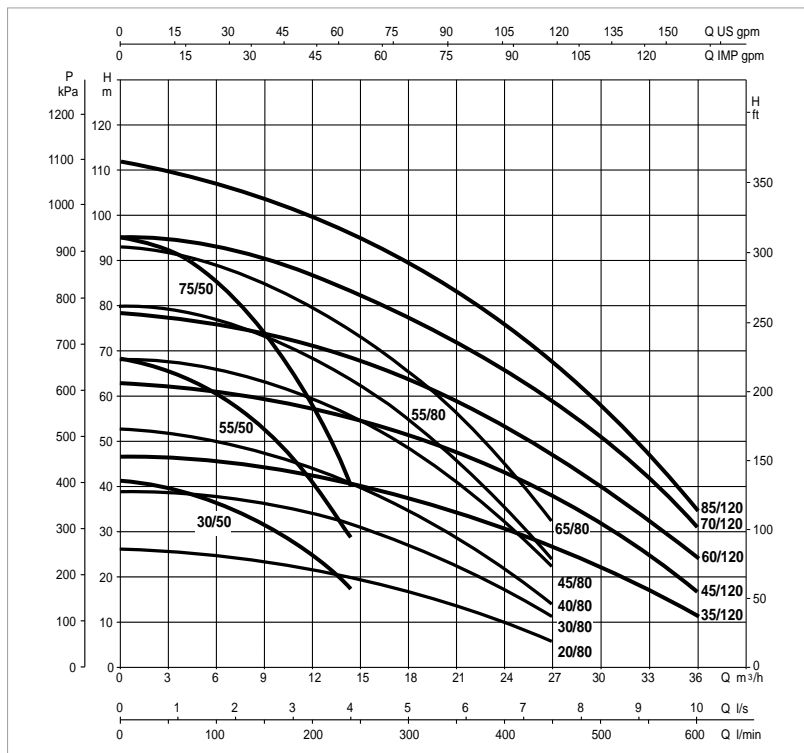
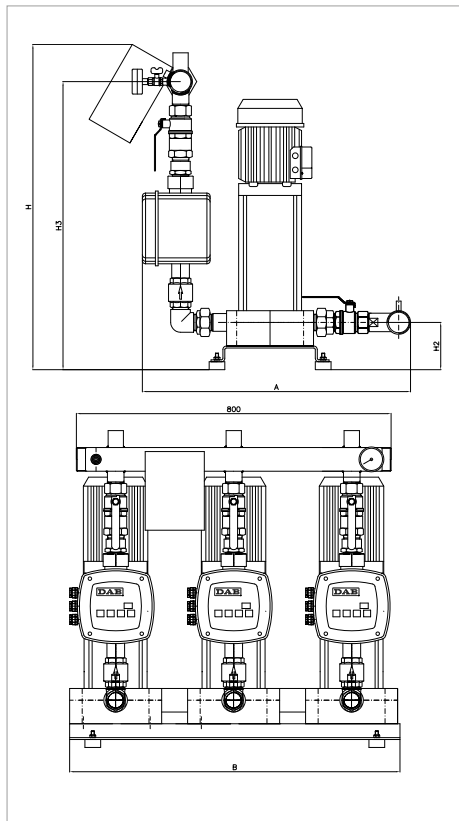

The performance curves are based on kinematic viscosity values = 1 mm²/s and density equivalent to 1000 kg/m³
Curve tolerance according to ISO 9906. **Overall performance taking into account THREE pumps working at the same time.**
The performance results of sets with smaller pumps (e.g. 3 KVC 20/50) are obtained through simple calibration of the AD

MODEL	POWER INPUT 50 Hz	P2 NOMINAL		In (set) A	ACTIVE DRIVER PLUS MODEL	FLOW m³/h	MAX PRESSURE BAR	STANDARD PRESSURE BAR
		KW	HP					
3 KVC AD 30/50	1x220-240 V~	3x0,55	3x0,75	3 x 4,1	MT 1,0	1,0 - 14,4	4,0	3,5
3 KVC AD 55/50	3x400 V~ + N *	3x1	3x1,36	3 x 7,6	MT 1,0	1,0 - 14,4	6,5	5,5
3 KVC AD 75/50	3x400 V~ + N *	3x1,5	3x2	3 x 10,7	MT 2,2	1,0 - 14,4	9,5	8,0
3 KVC AD 20/80	1x220-240V ~	3x0,55	3x0,75	3 x 4,8	MT 1,0	1,5 - 27,0	2,5	2,0
3 KVC AD 30/80	3x400 V~ + N *	3x0,9	3x1,2	3 x 6,5	MT 1,0	1,5 - 27,0	4,0	3,5
3 KVC AD 40/80	3x400 V~ + N *	3x1,1	3x1,5	3 x 7,7	MT 1,0	1,5 - 27,0	5,0	4,5
3 KVC AD 45/80	3x400 V~ + N *	3x1,5	3x2	3 x 9,6	MT 2,2	1,5 - 27,0	6,5	5,5
3 KVC AD 55/80	3x400 V~ + N *	3x1,85	3x2,5	3 x 11,2	MT 2,2	1,5 - 27,0	8,0	7,5
3 KVC AD 65/80	3x400 V~ + N *	3x2,2	3x3	3 x 12,0	MT 2,2	1,5 - 27,0	9,0	8,0
3 KVC AD 35/120	3x400 V~ + N *	3x1,1	3x1,5	3 x 10,4	MT 2,2	2,0 - 36	4,5	3,5
3 KVC AD 45/120	3x400 V~ + N *	3x1,85	3x2,5	3 x 13,6	MT 2,2	2,0 - 36	6,0	5,0
3 KVC AD 60/120	3x400 V	3x2,2	3x3	3 x 5,4	T/T 3,0	2,0 - 36	7,5	6,5
3 KVC AD 70/120	3x400 V	3x3,0	3x4	3 x 6,8	T/T 3,0	2,0 - 36	9,5	7,5
3 KVC AD 85/120	3x400 V	3x3,0	3x4	3 x 7,8	T/T 5,5	2,0 - 36	11,0	8,5

* Single phase power input also available on request (1x220-240 V~).

MODEL	A	B	H	H2	H3	DNA	DNM	PACKING DIMENSIONS			VOLUME m³	WEIGHT kg
								L/A	L/B	H		
3 KVC AD 30/50	750	900	740	100	710	2" 1/2	2" 1/2	1000	800	1400	1,2	131
3 KVC AD 55/50	750	900	740	100	710	2" 1/2	2" 1/2	1000	800	1400	1,2	141
3 KVC AD 75/50	750	900	740	100	710	2" 1/2	2" 1/2	1000	800	1400	1,2	150
3 KVC AD 20/80	750	900	740	100	710	2" 1/2	2" 1/2	1000	800	1400	1,2	132
3 KVC AD 30/80	750	900	740	100	710	2" 1/2	2" 1/2	1000	800	1400	1,2	136
3 KVC AD 40/80	750	900	740	100	710	2" 1/2	2" 1/2	1000	800	1400	1,2	145
3 KVC AD 45/80	750	900	740	100	710	2" 1/2	2" 1/2	1000	800	1400	1,2	150
3 KVC AD 55/80	750	900	740	100	710	2" 1/2	2" 1/2	1000	800	1400	1,2	152
3 KVC AD 65/80	750	900	740	100	710	2" 1/2	2" 1/2	1000	800	1400	1,2	156
3 KVC AD 35/120	750	900	740	100	710	2" 1/2	2" 1/2	1000	800	1400	1,2	150
3 KVC AD 45/120	750	900	740	100	710	2" 1/2	2" 1/2	1000	800	1400	1,2	156
3 KVC AD 60/120	750	900	740	100	710	2" 1/2	2" 1/2	1000	800	1400	1,2	162
3 KVC AD 70/120	750	900	740	100	710	2" 1/2	2" 1/2	1000	800	1400	1,2	168
3 KVC AD 85/120	750	900	740	100	710	2" 1/2	2" 1/2	1000	800	1400	1,2	170

The sets are supplied in a sturdy cardboard packaging on wooden pallet and installation / maintenance manual.



TECHNICAL DATA

Line voltage: 115V e 230V single phase. 400V three-phase.
Electric pump voltage: 115V e 230V single phase, 230V e 400V three-phase.
Frequency: 50 Hz - 60 Hz.
Installation: vertical or horizontal (for M/M e M/T).
Massima temperatura del liquido: 50°C.
Max. Liquid temperature: 50°C.
Portata max: 18m³/h.
Max. pressure: 13 bar.
Pressure regulation range: from 1 to 13 bar.
Aspiration diameter (DNA): 1 1/4" male.
Discharge diameter (DNM): 1 1/2" female.
Protection rating: IP55.
Communication interface for sets: Yes, an Active Driver per pump.

APPLICATIONS

The units with Active Driver were designed and manufactured to meet the needs for **constant pressure required** by modern plumbing systems. Constant pressure regulation is applicable to many sectors: Water supply for irrigation, industry, hotels, housing construction, thermal baths. The basic concept that guided our Engineers in the development of these units was to manufacture a system that is **simple, flexible and reliable**.

ADVANTAGES

Constant pressure - Quiet operation - Economical - Reduced water consumption - Smaller footprint (Expansion tanks not required) Less maintenance - Dry-running protection - Complete protection of the pump from faults.

ACTIVE DRIVER NOTES

The Active Driver inverter is a pump control device that includes the connections to the hydraulic system, a pressure sensor, a flow sensor, and an electronic frequency inverter. Active Driver is applied on the delivery of **each electric pump**, and regulates the rotation speed of the pump it is connected to, so that the **pressure is kept constant** in spite of variations in the required flow rate. The water flowing through the Active Driver Plus connections also contributes to **eliminating the heat** produced by the internal electric components.

OPERATION

Active Driver orders the pump to start as soon as it detects a request of water. The speed of the pump is (consistently) regulated at the minimum value that meets the request of the user. This ensures important energy savings. In this set, the second and third pump are activated in cascade when the first pump reaches the maximum rotation speed. The pump pressure may be adjusted by the user using the + and - buttons on Active Driver (usually all of the pumps are set at the same pressure level).

The pumps stop automatically when there is:

Pump overload - dry-running - low voltage - Maximum pressure exceeded (adjustable) - Active Driver electronics overheating.

ACTIVE DRIVER FUNCTIONS DISPLAYED

Pump operational frequency (Hz) - Real-time pressure (bar) - Amperes absorbed by the pump - Alarms.

ACTIVE DRIVER EXTERNAL CONNECTIONS (models M/T 2.2 - T/T 3.0 - T/T 5.5)

Inputs: pump disabling, pressure switch, float against dry operation, second pressure setpoint.

Outputs: two terminals with no potential for signaling alarms, pump stop, pump running.

MATERIALS

N°	PARTS*	MATERIALS
1	ACTIVE DRIVER PLUS BODY	VERPLEN
2	THREADED BRASS INSERT - 1-1/2 AS	BRASS
3	VNR HOUSING	NORYL
4 - 10 - 12 - 15 - 16 - 19	O-RING	NBR
5 - 20	O-RING	EPDM 70 WRAS
6	VNR GUIDE	NORYL
7	VNR BODY	NORYL
8	MAGNET	FERRITE + PARYLENE
9	VNR COVER	NORYL
11	O-RING	SILORPREN
13	SPRING SP1	STAINLESS STEEL
14	SCREW	STAINLESS STEEL
17	INSERT - 3/8" GAS	PPE 20GF
18	PRESSURE SENSOR	STAINLESS STEEL
21	HEAT DISPERSER	BRASS

* In contact with the liquid.

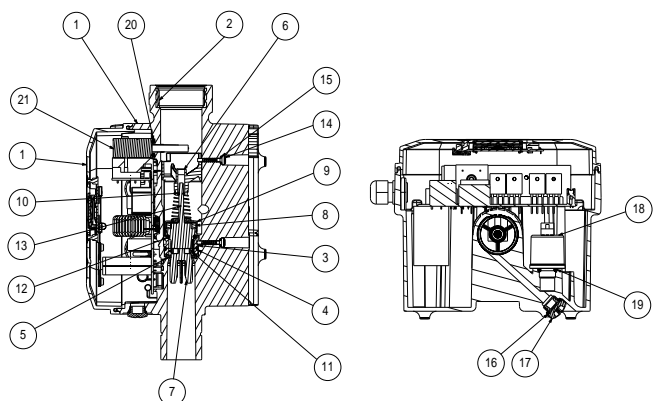

DNA[®]

PUMPS SELECTOR



On-line product selection



DAB PUMPS LTD.

Unit 4 and 5, Stortford Hall Industrial Park,
Dunmow Road,
Bishops Stortford,
Herts
CM23 5GZ - UK
salesuk@dwtgroup.com
Tel. +44 1279 652 776
Fax +44 1279 657 727



DAB PUMPS IBERICA S.L.

Calle Verano 18-20-22
28850 - Torrejón de Ardoz - Madrid
Spain
Info.spain@dwtgroup.com
Tel. +34 91 6569545
Fax: + 34 91 6569676



DAB PUMPS SOUTH AFRICA

Twenty One industrial Estate,
16 Purlin Street, Unit B, Warehouse 4
Olifantsfontein -1666 - South Africa
info.sa@dwtgroup.com
Tel. +27 12 361 3997



DAB PUMPS B.V.

Brusselstraat 150
B-1702 Groot-Bijgaarden - Belgium
info.belgium@dwtgroup.com
Tel. +32 2 4668353
Fax +32 2 4669218



DAB PUMPS HUNGARY KFT.

H-8800
Nagykanizsa, Buda Ernő u.5
Hungary
Tel. +36 93501700



DAB PUMPS (QINGDAO) CO. LTD.

No.40 Kaituo Road, Qingdao Economic & Technological
Development Zone
Qingdao City, Shandong Province - China
PC: 266500
sales.cn@dwtgroup.com
Tel. +86 400 186 8280
Fax +86 53286812210



DAB PUMPS POLAND Sp. z o.o.

Ul. Janka Muzykanta 60
02-188 Warszawa - Poland
polska@dabpumps.com.pl



DAB PUMPS B.V.

Albert Einsteinweg, 4
5151 DL Drunen - Nederland
info.netherlands@dwtgroup.com
Tel. +31 416 387280
Fax +31 416 387299



OOO DAB PUMPS

Novgorodskaya str. 1, block G
office 308, 127247, Moscow - Russia
info.russia@dwtgroup.com
Tel. +7 495 122 0035
Fax +7 495 122 0036



DAB PUMPS DE MÉXICO, S.A. DE C.V.

Av Amsterdam 101 Local 4
Col. Hipódromo Condesa,
Del. Cuauhtémoc CP 06170
Ciudad de México
Tel. +52 55 6719 0493



DAB PUMPEN DEUTSCHLAND GmbH

Tackweg 11
D - 47918 Tönisvorst - Germany
info.germany@dwtgroup.com
Tel. +49 2151 82136-0
Fax +49 2151 82136-36



DAB PUMPS INC.

3226 Benchmark Drive
Ladson, SC 29456 - USA
info.usa@dwtgroup.com
Tel. 1- 843-797-5002
Fax 1-843-797-3366



DAB PUMPS OCEANIA PTY LTD

426 South Gippsland Hwy,
Dandenong South VIC 3175 - Australia
info.oceania@dwtgroup.com
Tel. +61 1300 373 677