

01284 658770

sales@automatedenvironmentalsystems.co.uk

Commercial Swimming Pool Heat Pump

- Installation and Service Manual -
(Inverter Type)



BP700R

TABLE OF CONTENT

INTRODUCTION	3
General information	3
Items inside product box	3
SAFETY PRECAUTIONS	4
Warning	4
Caution.....	5
OVERVIEW OF THE UNIT	7
External view:	
BP700R	7
Exploded view:	
BP700R	8
OPERATING THE UNIT	9
Features and function.....	9
USER INTERFACE	10
PARAMETER CHECKIN	13
Error Code	14
WIRING DIAGRAM	15
INSTALLATION OF THE UNIT	16
Installation guidelines	16
Precautions for selecting the location	16
Selecting a location in cold climates	16
Installation space	17
Mounting the unit	17
Water pipe work	17
Checking the water circuit	17
Connecting the water circuit	18
Charging water	19
Piping insulation	19
Field wiring	19
Pre-operation Checks	20
Checks before initial start-up	20
MAINTENANCE	21
PLUMBING CONNECTIONS	22
TROUBLESHOOTING	24
Environmental liformation	26
Disposal requirements	26
WIFI / APP APPLICATION	27

INTRODUCTION

This manual includes the necessary information about the unit. Please read this manual carefully before you install, operate and maintain the unit.

General information

The heat pump water heater is one of the most economical systems to heat the water for family domestic use. Using free renewable energy form the air, the unit is highly efficient with low running costs. Its efficiency can be up to 5-6 times more than conventional gas boiler or electrical heater.

It can offer hot water all year around. Also it can be compatible with the existing geyser in household.

Items inside product box

Thank you for choosing the heat pump water heater.

Before starting installation, please make sure that all parts are found inside the product box.

The Unit Box		
Item	Image	Quantity
Heat pump unit		1
Installation and Service Manual		1
Controller		1

SAFETY PRECAUTIONS

To prevent injury to the user, other people, or property damage, the following instructions must be followed. Incorrect operation due to ignoring of instructions may cause harm or damage.

Install the unit only when it complies with local regulations, by-laws and standards. Check the main voltage and frequency. This unit is only suitable for earthed sockets.

The following safety precautions should always be taken into account:

- Be sure to read the following WARNING before installing the unit.
- Be sure to observe the cautions specified here as they include important items related to safety.
- After reading these instructions, be sure to keep it together with the manual in a handy place for future reference.



Do not install the unit yourself.

Incorrect installation could cause injury due to fire, electric shock, the unit falling or leakage of water. Consult the dealer from whom you purchased the unit or a specialized installer.

Install the unit securely in a place.

When insufficiently installed, the unit could fall causing injury. When installing the unit in a small room, please take measures (like sufficient ventilation) to prevent the asphyxia caused by the leakage of refrigerant.

Use the specified electrical wires and attach the wires firmly to the terminal board (connection in such a way that the stress of the wires is not applied to the sections).

Incorrect connection and fixing could cause a fire.

Be sure to use the provided or specified parts for the installation work.

The use of defective parts could cause an injury due to possible fire, electric shocks, the unit falling etc.

Perform the installation securely and please refer to the installation instructions.

Incorrect installation could cause an injury due to possible fire, electric shocks, the unit falling, leakage of water etc.

Perform electrical work according to the installation manual and be sure to use a dedicated section.

If the capacity of the power circuit is insufficient or there is an incomplete electrical circuit, it could result in a fire or an electric shock.

The unit must always have an earthed connection.

If the power supply is not earthed, you may not connect the unit.

Never use an extension cable to connect the unit to the electric power supply.

If there is no suitable, earthed wall socket available, have one installed by a recognized electrician.

Do not move/repair the unit yourself.

Improper movement or repair on the unit could lead to water leakage, electrical shock, injury or fire. Have any repairs and/or maintenance only carried out by a recognized service engineer.

Do not plug or unplug the power supply during operation

There is a risk of fire or an electric shock

Do not touch/operate the unit with wet hands

There is a risk of fire or an electric shock

Do not place a heater or other appliances near the power cable

There is a risk of fire or an electric shock

Be cautious that water could not be poured to the product directly, do not allow water to run into electric parts

There is a risk of fire or an electric shock



IF THE PRODUCT IS NOT USED FOR A LONG TIME, WE STRONGLY RECOMMEND NOT TO SWITCH 'OFF' THE POWER SUPPLY OF THE UNIT.



IF THE POWER IS NOT SUPPLIED, SOME SPECIAL PRODUCT-PROTECTING ACTIONS (SUCH AS ANTI-FREEZE) WILL NOT BE PERFORMED.



CAUTION

Do not install the unit in a place where there is a chance of flammable gas leaks.

If there is a gas leak and gas accumulates in the area surrounding the unit, it could cause an explosion.

Perform the drainage/piping work according to the installation instruction.

If there is a defect in the drainage/piping work, water could leak from the unit and household goods could get wet and be damaged.

Do not clean the unit when the power is 'on'.

Always shut 'off' the power when cleaning or servicing the unit. If not, it could cause an injury due to the high speed running fan or an electrical shock.

Do not continue to run the unit when there is something wrong or there is a strange smell.

The power supply needs to be shut 'off' to stop the unit; otherwise this may cause an electrical shock or fire.

Be cautious when unpacking and installing the product.

Sharp edges could cause injury. Especially watch the edges and the fins on the heat exchanger of the product.

Always check for gas (refrigerant) leakage after installation or repair of product.

Low refrigerant levels may cause failure of the product.

Keep level even when installing the product.

This is to avoid vibration or water leakage.

Do not put your fingers or others into the fan, or evaporator.

The ventilator runs at high speed, this could cause serious injury.

OVERVIEW OF THE UNIT

External view: BP700R

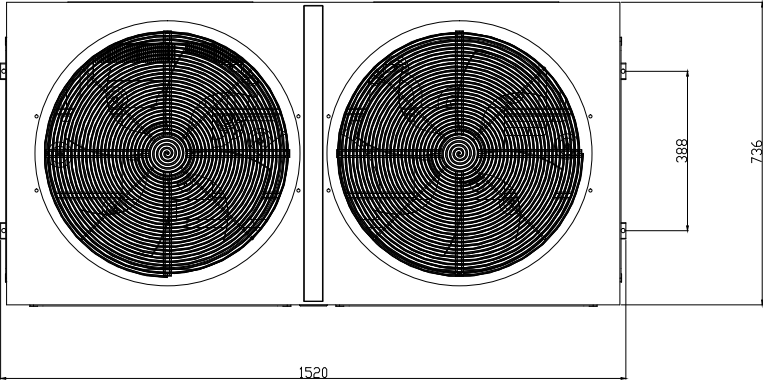
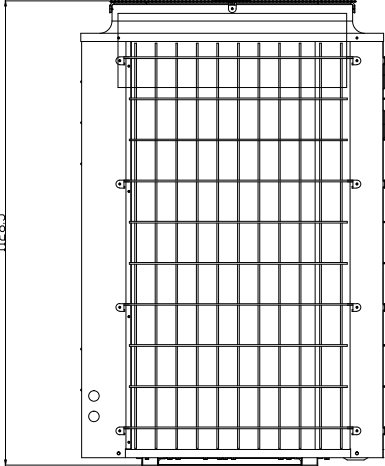
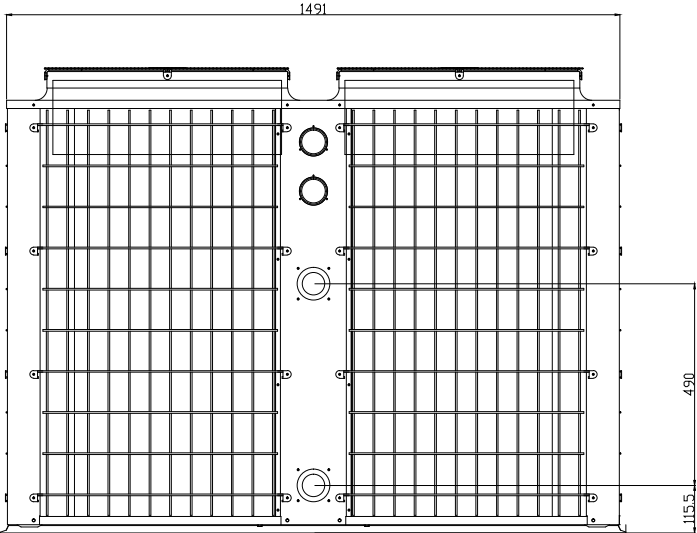

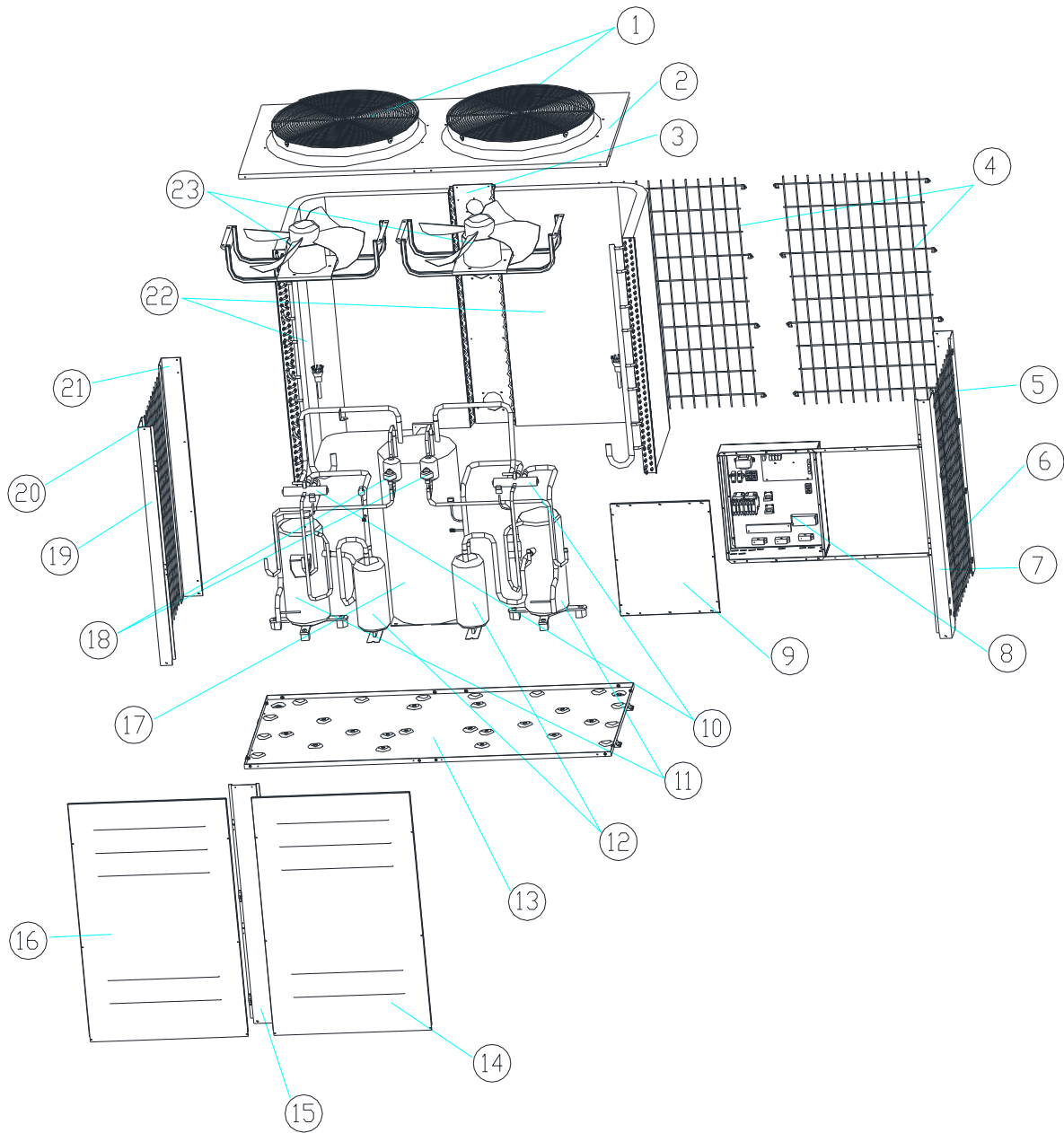

Exploded view: BP700R



Item	Description	Item	Description
1	Top grill	13	Bottom plate assembly
2	Top cover	14	Front right panel
3	Rear middle pillar	15	Front middle pillar
4	Rear grill	16	Front left panel
5	Rear right pillar	17	Titanium heat exchanger
6	Right grill	18	EEV assembly
7	Front right pillar	19	Front left pillar
8	Electrical control assembly	20	Left grill
9	Electrical control box cover	21	Rear left pillar
10	4-way valve assembly	22	Evaporator assembly
11	Compressor	23	Fan assembly
12	Reservoir		

OPERATING THE UNIT

Operating the unit comes down to operating the digital controller.

-  NEVER LET THE DIGITAL CONTROLLER GET WET. THIS MAY CAUSE AN ELECTRIC SHOCK OR FIRE.
-  NEVER PRESS THE BUTTONS OF THE DIGITAL CONTROLLER WITH A HARD, POINTED OBJECT. THIS MAY DAMAGE THE DIGITAL CONTROLLER.
-  NEVER INSPECT OR SERVICE THE DIGITAL CONTROLLER YOURSELF, ASK A QUALIFIED SERVICE PERSON TO DO THIS.

Features and functions

Basic controller functions

The basic controller functions are:





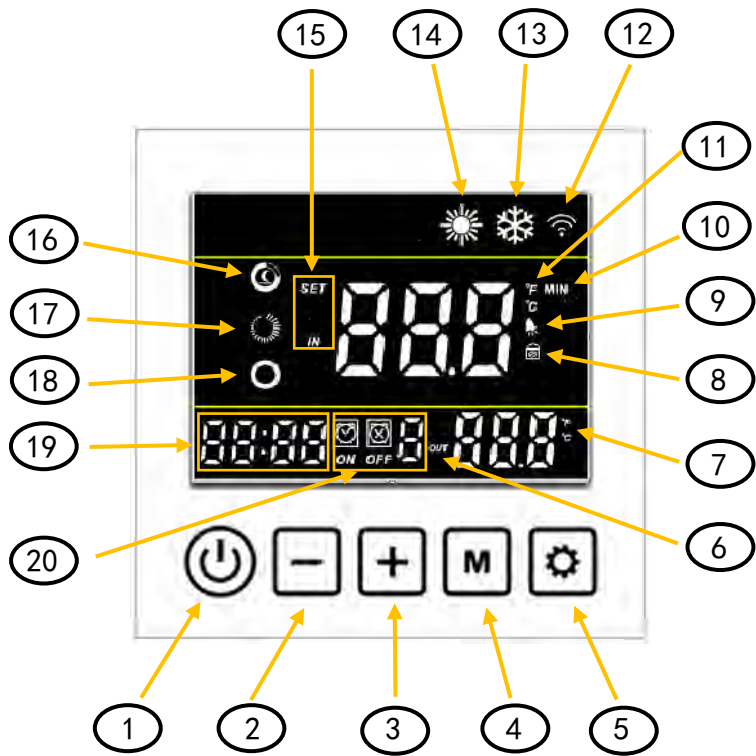



- Turning the heat pump 'ON'/'OFF'.
- 24 hours real time clock.
- Timer 'ON' and timer 'OFF'.
- Parameter adjustment

USER INTERFACE





1	ON/OFF	2	DOWN	3	UP	4	Mode
5	Setup	6	Outlet water temp	7	Temperature(°F/°C)	8	Lock Screen
9	Alarm Display	10	Time (MIN)	11	Temperature (°F/°C)	12	WIFI Indicator
13	Cooling mode	14	Heating Mode	15	IN-- Inlet water temp , SET- Setting parameters		
16	Silent mode	17	Smart mode	18	Boost mode	19	Clock
20	ON-- Timer ON , OFF-- Timer OFF ,  -- Timer number						

Icon Introduction:

1. Heating mode, display symbol 
2. Cooling mode, display symbols 
3. Silent mode  Intelligent mode  Boost mode 
4.  This icon will show when defrost is running.
5. When the Wi-Fi connection is successful, the  will remain on for a long time, and will flash when there is no connection or during the connection.
6.  This icon will show when screen is locked.
7.  flashes when a fault is reported.

Key operation instructions

1. “” ON/OFF

Short press “” as Exit Key to return to main interface, press and hold the “” key for 3 seconds to turn the unit ON or OFF.

2. “” Mode





When the unit is ON, long press “” for 3 seconds to switch different working modes: Heating mode and Cooling mode.

3. “” key

On the main operation interface, click “” to adjust setting temperature of current mode.













4. “” Key

On the main interface, click “” to adjust current mode setting temperature.

On the main operation interface, press and hold “” key for 3 seconds to enter Unit Running Status Parameter Query, and use the “”、“” keys to navigate different parameters, press the “” key to exit. **(SEE PAGE 13)**.





5. “” Setup key







Clock settings:

Press and hold “”和“” for 3 seconds before entering the clock setting state. First, the hour bit flashes, indicating that the hour value of the current time can be adjusted using the “”、“” keys. Each time the “” key is pressed, the hour is increased by one, and each time the “” key is pressed, the hour is decreased by one. If you hold down the “” or “” key for a long time, the hours will automatically increase or decrease. After setting the hour value, press the “” key again. At this time, the minute bit flashes, indicating that the minute value of the current time can be adjusted using the “”、“” key. After setting the minute value, press the “” key again to end.

Timer settings:

Press and hold the  key for 3 seconds to enter Timer setting:

"Timer On 1" "Hour" flashes. With 、，you can set the hour; Press  key again to switch to the Timer "minute", and use the 、 keys to set the Timer minute;

Press the  key again to switch to the "Timing Off 1" "Hour" flashes. With 、，you can set the hour; Press  key again to switch to the Timer "minute", and use 、 keys to set the Timer minute;



Other Timer settings are same as above.

Press  to exit or confirm. After returning to the main operation interface, it will display Timer numbers.

To cancel the Timer setting:

When settings of Timer ON and Timer OFF are same, this Timer will be cancelled.

6. Forced defrosting:



Press the  and  keys to enter the forced defrosting mode.

When entering defrosting, the "  " will flash.

7. Frequency mode switching

When the unit is ON, press  to switch different frequency modes: Silent, Smart, and Boost modes.

8. Celsius/Fahrenheit switching

When the unit is OFF, long press  and  on the main interface for 3 seconds to switch between Celsius and Fahrenheit.





9. Unlock/lock screen operation

On the main operation interface, press and hold the  and  keys for 3 seconds to unlock/lock the screen.

10. Manual electric heating function:





Press and hold  for 3 seconds on the main interface to manually turn on/off the electric heating function.

11. Restore factory settings

When the unit is OFF, press and hold the  +  +  +  for 3 seconds to restore the factory settings. At this time, the buzzer will sound twice continuously, and all parameter values will change back to the default values.

PARAMETER CHECKING

Unit running status table

On the main operation interface, press and hold “” key for 3 seconds to enter Unit Running Status Parameter Query, and use the “”、“” keys to navigate different parameters, press the “” key to exit.

© Unit Running Status Query Table: Long press “”Key

Code	Parameter Name	Display Range
A01	Inlet water temperature	-20~99°C
A02	Outlet water temperature	-20~99°C
A03	Ambient temperature	-20~99°C
A04	Exhaust gas temperature	0~125°C
A05	Suction gas temperature	-30~99°C
A06	Outer coil tube temperature	-30~99°C
A07	Inter coil tube temperature	-30~99°C
A08	Main expansion valve opening angle	
A09	Enthalpy expansion valve opening angle	
A10	Compressor current	
A11	Heatsink temperature	
A12	DC bus voltage value	
A13	Actual compressor speed	
A14	1# DC fan speed	
A15	2# DC fan speed	
A16	Exhaust gas temperature 2	0~125°C
A17	Suction gas temperature 2	-30~99°C
A18	Heating coil 2 temperature	-30~99°C
A19	Cooling coil 2 temperature	-30~99°C
A20	Main valve 2 opening angle	
A21	Compressor current 2	
A22	Heatsink 2 temperature	
A23	Voltage value of DC bus 2	
A24	Actual rotation speed of compressor 2	
A25	DC fan 1 speed (module 2)	
A26	DC fan 2 speed (module 2)	

Error Code

Error codes	Fault description	Marks
Er 03	Water flow fault	
Er 04	Antifreeze in winter	
Er 05	High pressure fault	
Er 06	Low pressure fault	
Er 09	Communication failure	
Er 10	Communication failure of inverter module (Alarm activated when communication between PCB and IPM board is disconnected.)	
Er 12	High exhaust gas temperature protection	
Er 15	Inlet water temperature fault	
Er 16	Outer coil temperature fault	
Er 18	Exhaust gas temperature fault	
Er 19	1# DC fan fault	
Er 20	Abnormal inverter module protection	
Er 21	Ambient temperature fault	
Er 23	Cooling mode low outlet water temperature protection	
Er 22	2# DC fan fault	
Er 27	Outlet water temperature fault	
Er 28	CT overcurrent protection	
Er 29	Suction gas temperature fault	
Er 32	Heating mode high outlet water temperature protection	
Er 33	Outdoor coil high temperature protection	
Er 42	Inner coil temperature fault	
Er 60	High pressure #2 fault	
Er 61	Low pressure #2 fault	
Er 62	Heating coil #2 temperature fault	
Er 63	Cooling coil #2 temperature fault	
Er 64	Exhaust gas #2 temperature fault	
Er 65	Suction gas #2 temperature fault	
Er 66	High exhaust gas #2 temperature fault	
Er 67	Outdoor coil #2 high temperature protection	
Er 68	System #2 fan #1 fault	
Er 69	System #2 fan #2 fault	
Er 70	Abnormal inverter module #2 protection	
Er 71	Communication failure of inverter module #2	
Er 72	Communication failure of fan drive board	
Er 73	Communication failure of fan driver board supplier by customer	
Er 74	Customer supplied DC fan fault	

WIRING DIAGRAM of BP700R

(Please refer to the attached wiring diagram on the unit.)

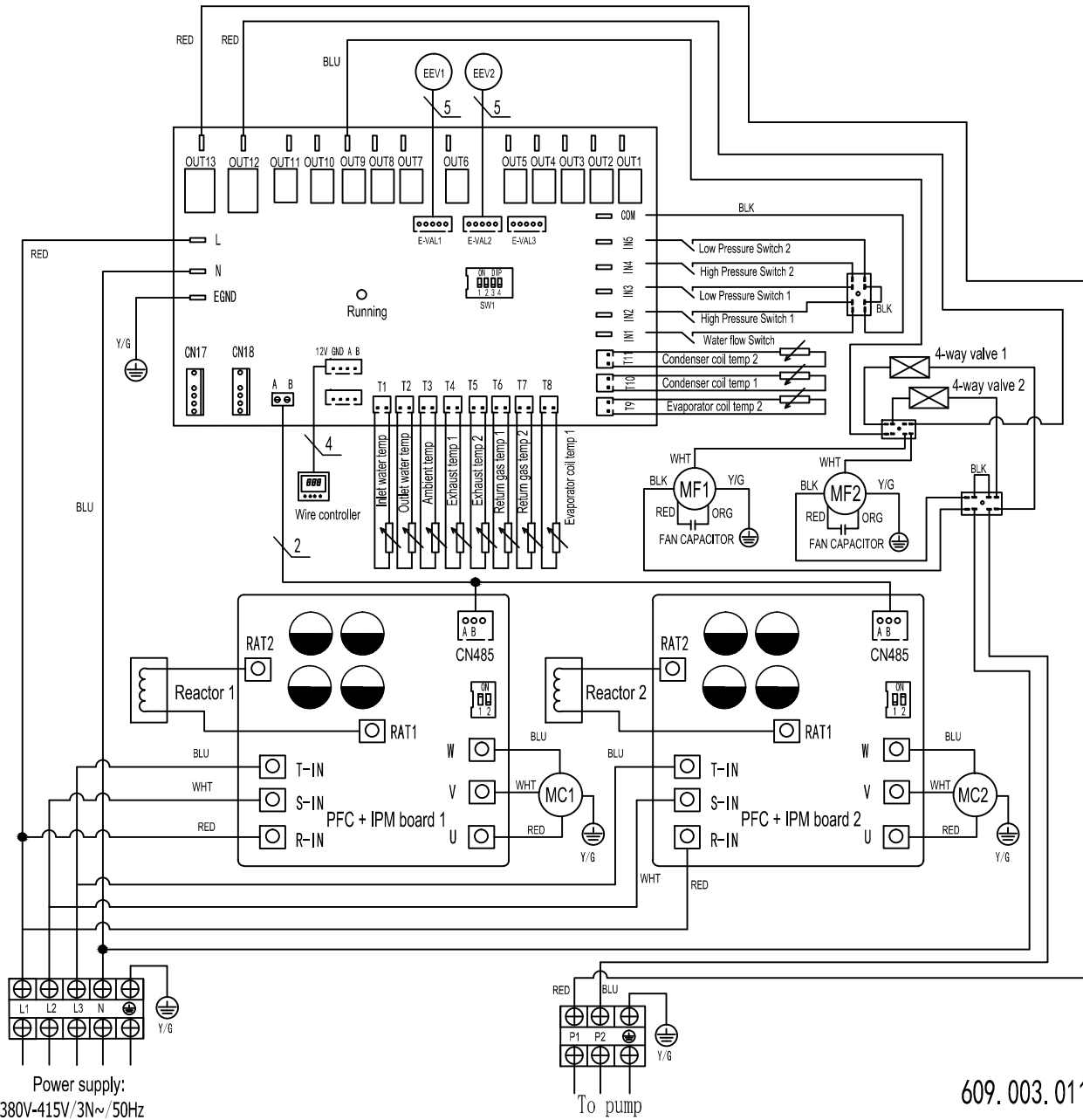

INSTALLATION OF THE UNIT

Installation guidelines

Precautions for selecting the location



MAKE SURE TO PROVIDE FOR ADEQUATE MEASURES IN ORDER TO PREVENT THAT THE OUTDOOR UNIT WILL BE USED AS A SHELTER FOR SMALL ANIMALS.



SMALL ANIMALS MAKING CONTACT WITH ELECTRICAL PARTS CAN CAUSE MALFUNCTIONS, SMOKE OR FIRE. PLEASE KEEP THE AREA AROUND THE UNIT CLEAN.

1. Choose a place solid enough to bear the weight and vibration of the unit, where the operation noise will not be amplified.
2. Choose a location where the hot air discharged from the unit or the operation noise will not cause a nuisance to the neighbors of the user.
3. Avoid places near a bedroom and the like, so that the operation noise will cause no trouble.
4. There must be sufficient space for carrying the unit into and out of the site.
5. There must be sufficient space for air passage and no obstructions around the air inlet and the air outlet.
6. Locate the unit so that the noise and the discharged hot air will not annoy the neighbors.
7. The site must be free from the possibility of flammable gas leakage in a nearby place.
8. Install units, power cords and inter-unit cables at least 3m away from television and radio sets. This is to prevent interference to images and sounds.
9. Depending on radio wave conditions, electromagnetic interference can still occur even if installed more than 3m away.
10. In coastal areas or other places with salty atmosphere of sulfate gas, corrosion may shorten the life of the outdoor unit.
11. Since drain flows out of the outdoor unit, do not place anything under the unit which must be kept away from moisture.

Selecting a location in cold climates



WHEN OPERATING THE OUTDOOR UNIT IN A LOW OUTDOOR AMBIENT TEMPERATURE, BE SURE TO FOLLOW THE INSTRUCTIONS DESCRIBED BELOW.

- To prevent exposure to wind, install the outdoor unit with its suction side facing the wall.
- Never install the outdoor unit at a site where the suction side may be exposed directly to wind.
- To prevent exposure to wind, install a baffle plate on the air discharge side of the outdoor unit.
- In heavy snowfall areas it is very important to select an installation site where the snow will not affect the unit. If lateral snowfall is possible, make sure that the heat exchanger coil is not affected by the snow (if necessary construct a lateral canopy).

Installation space

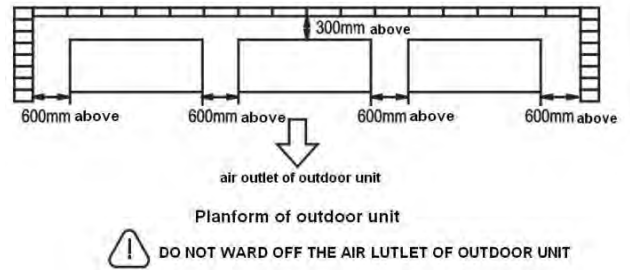
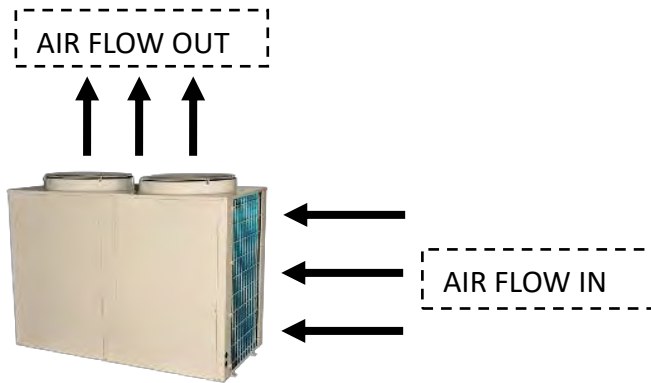

Mounting the unit

When installing the outdoor unit, please refer to “Installation guidelines” to select an appropriate location.

1. Check the strength and level of the installation ground so that the unit will not cause any operating vibration or noise after installation.
2. Prepare 4 sets of M8 foundation bolts, nuts and washers each (filed supply).
3. Fix the unit securely by means of the foundation bolts in accordance with the foundation drawing. It is best to screw in the foundation bolts until their length remains 20mm above the foundation surface.

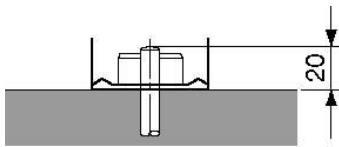

Water pipe work

Checking the water circuit

The water circuits must be provided by a licensed technician and must comply with all relevant European and national regulations.



THE UNIT IS ONLY TO BE USED IN A CLOSED WATER SYSTEM. APPLICATION IN AN OPEN WATER CIRCUIT CAN LEAD TO EXCESSIVE CORROSION OF THE WATER PIPING.

Before continuing the installation of the unit, check the following points:

- The maximum water pressure is 6 bar.
- Two stop valves are not delivered with the unit. To facilitate service and maintenance, please install one at each water inlet/outlet. Mind position of the stop valves. Orientation of the integrated drain and fill valves is important for servicing.

- Drain taps must be provided at all low points of the system to permit complete drainage of the circuit during maintenance.
- Air vents must be provided at all high points of the system. The vents should be located at points which are easily accessible for servicing. Do the air purge during the installation.
- Take care that the components installed in the field piping can withstand the water pressure.

Connecting the water circuit

Water connections must be made in accordance with the outlook diagram delivered with the unit, respecting the water in and outlet



BE CAREFUL NOT TO DEFORM THE UNIT PIPING BY USING EXCESSIVE FORCE WHEN CONNECTING THE PIPING. DEFORMATION OF THE PIPING CAN CAUSE THE UNIT TO MALFUNCTION.

If air, moisture or dust gets in the water circuit, problems may occur.

Therefore, always take into account the following when connecting the water circuit:

- Use clean pipes only.
- Hold the pipe end downwards when removing burrs.
- Cover the pipe end when inserting it through a wall so that no dust and dirt can enter.
- Use a good thread sealant for the sealing of the connections.
- The sealing must be able to withstand the pressures and temperatures of the system.
- When using non-brass metallic piping, make sure to insulate both materials from each other to prevent galvanic corrosion.
- Because brass is a soft material, use appropriate tooling for connecting the water circuit. Inappropriate tooling will cause damage to the pipes.



THE UNIT IS ONLY TO BE USED IN A CLOSED WATER SYSTEM. APPLICATION IN AN OPEN WATER CIRCUIT CAN LEAD TO EXCESSIVE CORROSION OF THE WATER PIPING.



NEVER USE ZN-COATED PARTS IN THE WATER CIRCUIT. EXCESSIVE CORROSION OF THESE PARTS MAY OCCUR AS COPPER PIPING IS USED IN THE INTERNAL WATER CIRCUIT OF THE UNIT.



WHEN USING A 3-WAY VALVE OR A 2-WAY VALVE IN THE WATER CIRCUIT. THE RECOMMENDED MAXIMUM CHANGE-OVER TIME OF THE VALVE SHOULD BE LESS THAN 60 SECONDS.

Charging water

1. Connect the water supply to a drain and fill valve.



NOTE

- Water quality must be according to EN directive 98/83 EC.

Piping insulation

The complete water circuit, inclusive all piping, must be insulated to prevent and reduction of the heating capacity.

Field wiring



WARNING

- A main switch or other means for disconnection, having a contact separation in all poles, must be incorporated in the fixed wiring in accordance with relevant local and national legislation.
- Switch 'off' the power supply before making any connections.
- All field wiring and components must be installed by a licensed electrician and must comply with relevant European and national regulations.
- The field wiring must be carried out in accordance with the wiring diagram supplied with the unit and the instructions given below.
- Be sure to use a dedicated power supply. Never use a power supply shared by another appliance.
- Be sure to establish an earth. Do not earth the unit to a utility pipe, surge absorber, or telephone earth. Incomplete earth may cause electrical shock.
- Be sure to install an earth leakage protector.

Failure to do so may cause electrical shock.

Wiring overview

The table below gives a wiring overview of the required field wiring.

Model	BP700R
Power supply	$\geq 4.0 \text{ mm}^2 \times 5$

Pre-operation checks

Checks before initial start-up



SWITCH OFF THE POWER SUPPLY BEFORE MAKING ANY CONNECTIONS.

After the installation of the unit, check the following before switching on the circuit breaker:

1. Field wiring

Make sure that the field wiring between the local supply panel and domestic hot water tank has been carried out according to the instructions, according to the wiring diagrams and according to European and national regulations.

2. Fuses or protection devices

Check that the fuses or the locally installed protection devices are of the size and type specified. Make sure that neither a fuse nor a protection device has been bypassed.

3. Earth wiring

Make sure that the earth wires have been connected properly and that the earth terminals are tightened.

4. Internal wiring

Visually check the switch box on loose connections or damaged electrical components.

5. Fixation

Check that the unit is properly fixed, to avoid abnormal noises and vibrations when starting up the unit.

6. Damaged equipment

Check the inside of the unit on damaged components or squeezed pipes.

7. Refrigerant leakage

Check the inside of the unit on refrigerant leakage. If there is a refrigerant leak, call your local dealer.

8. Power supply voltage

Check the power supply voltage on the local supply panel. The voltage must correspond to the voltage on the identification label of the unit.

9. Water flow switch should be installed for the place where there is no constant sufficient water flow (Field supply).

10. Stop valves

Make sure that the stop valves are correctly installed and fully open.



OPERATING THE SYSTEM WITH CLOSED VALVES WILL DAMAGE THE PUMP!

MAINTENANCE

In order to ensure optimal availability of the unit, a number of checks and inspections on the unit and the field wiring have to be carried out at regular intervals.



BEFORE CARRYING OUT ANY MAINTENANCE OR REPAIR ACTIVITY, ALWAYS SWITCH 'OFF' THE CIRCUIT BREAKER ON THE SUPPLY PANEL, REMOVE THE FUSES OR OPEN THE PROTECTION DEVICES OF THE UNIT.



MAKE SURE THAT BEFORE STARTING ANY MAINTENANCE OR REPAIR ACTIVITIES THE POWER SUPPLY TO THE OUTDOOR UNIT IS SWITCHED 'OFF'.

PLUMBING CONNECTIONS

The heat pump should be connected to a filtration circuit through a by-pass which consists of 3 valves. It is imperative that the by-pass is placed after the pump and the filter. These valves allow to regulate the water flow which passes through the heat pump and to isolate the heat pump completely for any maintenance work, without cutting the filtration flow.

If your installation is equipped with water treatment devices (chlorine, bromine feeder, salt water chlorine generator, others) the by-pass must be installed before the water treatment devices, with a non-return check valve between the by-pass and water treatment devices.

Water inlet and outlet are designed to be connected to rigid pressure PVC tube (for swimming pool) 40mm, directly glued to the union connectors provided.

Water pipes must be fixed on the floor or the walls, so the heat pump will not support the weight of the water inside the plumbing.

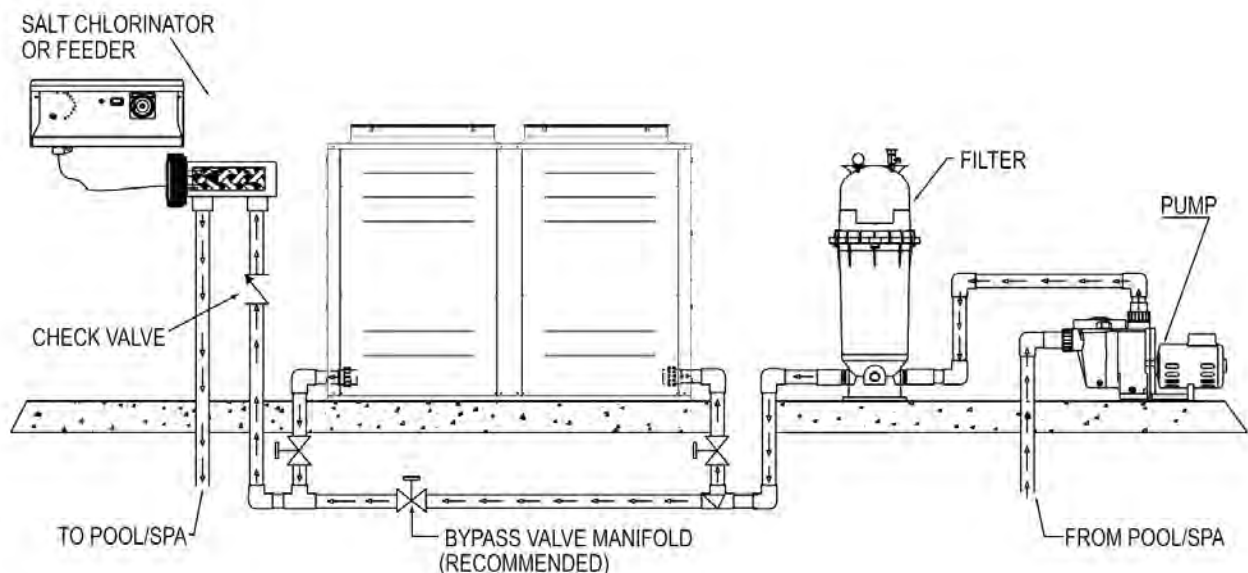

MAINTENANCE

To protect the paintwork, avoid leaning or putting objects on the shell. External Heat Pump parts can be wiped with a damp cloth and domestic cleaner. (Warning: Never use cleaning agents containing sand, soda, acid or chloride as these can damage the surfaces.)

To prevent blockages in the titanium heat exchanger, ensure that the system incorporates a water and filter treatment facility. In the event of a problem occurring due to contamination, the system should be cleaned as described below. (Warning: the fins on the finned tube heat exchanger are sharp!).

Cleaning the Heat Exchanger and Pipework

Contamination in the pipes and heat exchanger can reduce the performance of the heat pumps' titanium heat exchanger. If this is the case, the pipe system and heat exchanger must be cleaned by a technician.

Use only pressurized drinking water for cleaning.

Cleaning the air system

The finned heat exchanger, fan and condensate outflow should be clear of all obstructions (leaves, twigs, etc.) before each new heating season. These can be manually removed using compressed air or by flushing with clean water.

It may be necessary to remove the unit cover and air inlet grid first.

Attention: Before opening the unit, ensure that all electrical supplies are isolated.

To prevent the evaporator and the condensate tray from being damaged, do not use hard or

sharp objects for cleaning.

Under extreme weather conditions (e.g. snow drifts), ice may form on the air intake and exhaust air outlet grids. If this happens, the ice must be removed in the vicinity of the air intake and exhaust air outlet grids to ensure that the minimum air flow rate is maintained.

Winter Shutdown.

To prevent frost damage to the unit when not in use the Heat Pump should be drained of all water. Failing this another form of frost protection should be considered and actioned.

Attention: The warranty does not cover damage caused by inadequate frost protection measures during the winter.

TROUBLESHOOTING

This section provides useful information for diagnosing and correcting certain problems which may occur. Before starting the troubleshooting procedure, carry out a thorough visual inspection of the unit and look for obvious defects such as loose connections or defective wiring.

Before contacting your local dealer, read this chapter carefully. It could save you time and money.



WHEN CARRYING OUT ANY MAINTENANCE ENSURE ADEQUATE PRECAUTIONS ARE TAKEN TO PREVENT AN ELECTRIC SHOCK .

The hints below are for guidance only. If you cannot solve the problem, consult your installer/local dealer.

The Heat pump will not run.

Please check:

- There is a supply voltage (tripped fuse, power failure).
- The switch on the wired controller is switched on, and whether the correct set point temperature has been set.

The set temperature level cannot be reached.

Please check whether:

- The permissible operating conditions for the heat pump have been adhered to (air temperatures too high or too low).
- The air inlet or outlet area is blocked, restricted or very dirty.
- There are closed valves or stop-cocks in the water pipes.

The timer works but the programmed actions are executed at the wrong time (e.g. 1 hour too late or too early).

Please check whether:

- The clock and the day of the week are set correctly, adjust if necessary.

If you cannot correct the fault yourself, please contact your after-sales service technician.

Work on the heat pump may only be carried out by authorized and qualified after-sales service technicians.

ENVIRONMENTAL INFORMATION

This equipment contains fluorinated greenhouse gases covered by the Kyoto Protocol. It should only be serviced or dismantled by professional trained engineers.

This equipment contains R32 refrigerant in the amount as stated in the specification. Do not vent R32 into the atmosphere: R32, is a fluorinated greenhouse gas with a Global Warming Potential (GWP) = 675.

DISPOSAL REQUIREMENTS

Dismantling of the unit, treatment of the refrigerant, of oil and of other parts must be carried out in accordance with relevant local and national legislation.



Your product is marked with this symbol. This means that electrical and electronic products should not be mixed with unsorted household waste.

Do not try to dismantle the system yourself: the dismantling of the system, treatment of the refrigerant, of oil and other parts must be done by a qualified installer in accordance with relevant local and national legislation.

Units must be treated at a specialized treatment facility for re-use, recycling and recovery. By ensuring that this product is disposed of correctly, you will help to prevent potential negative consequences for the environment and human health. Please contact the installer or local authority for more information.

WIFI / APP APPLICATION

1. Install APP.

Please search in the app store or scan the QR code below to install the APP "Smart life - Smart Living"

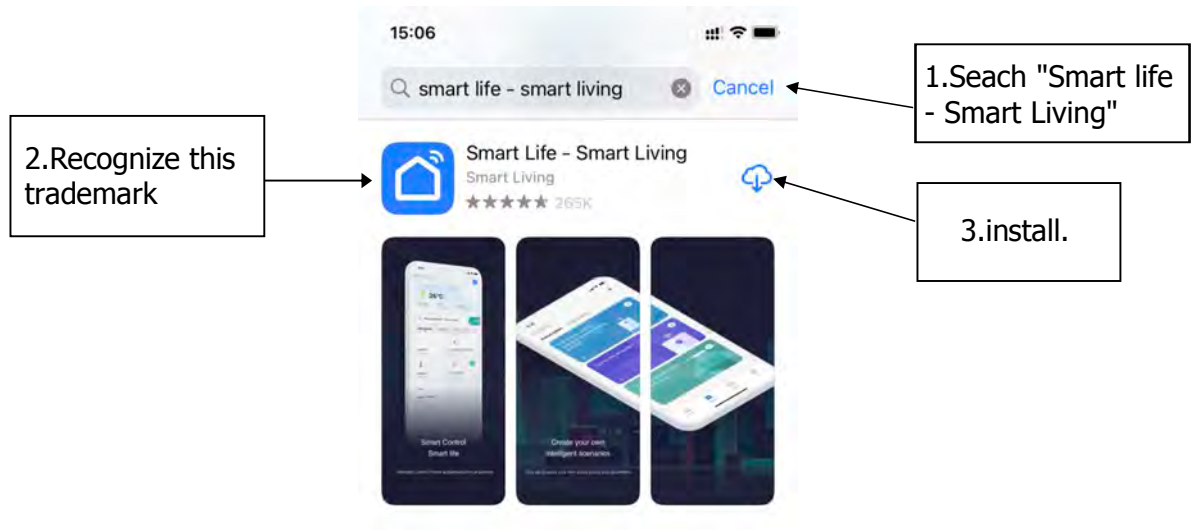

2. Startup software.

After the installation is complete, click on the desktop icon "Smart Life" to launch the software.



2.1 After installation completed, please open the APP to do Register Step below.

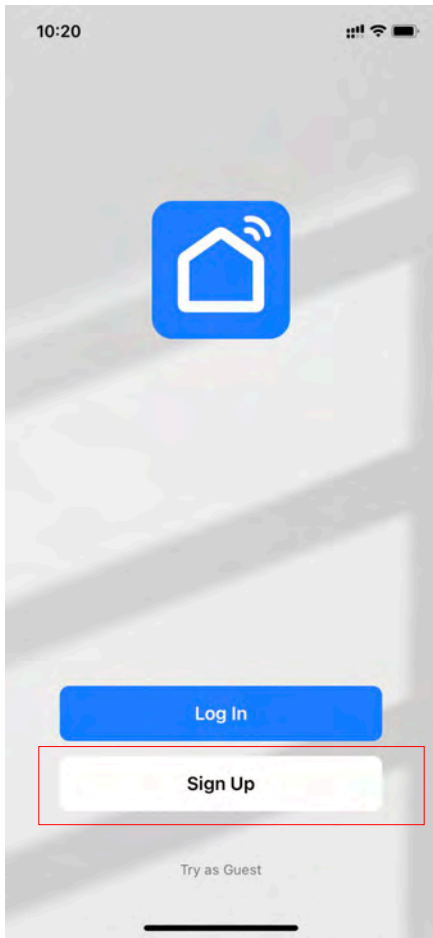

①

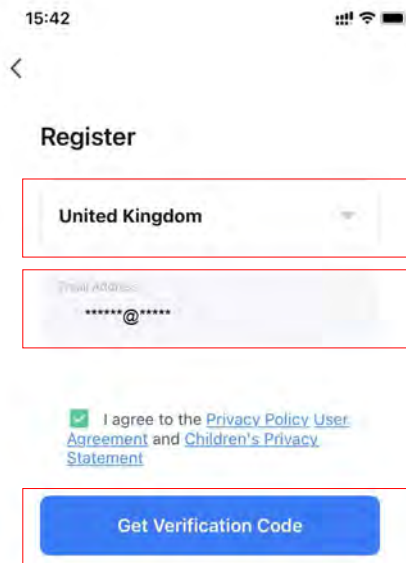

②



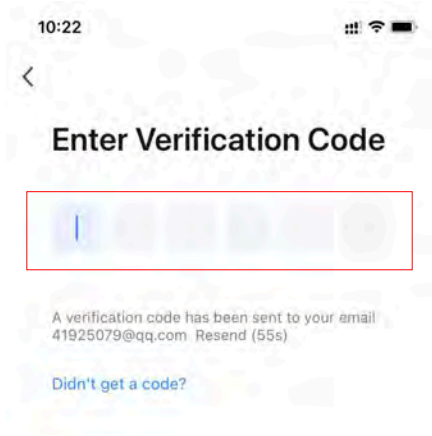

3

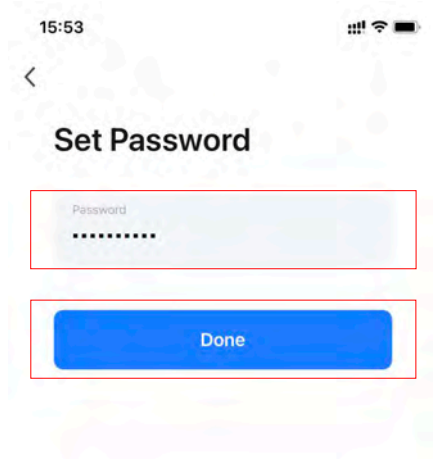
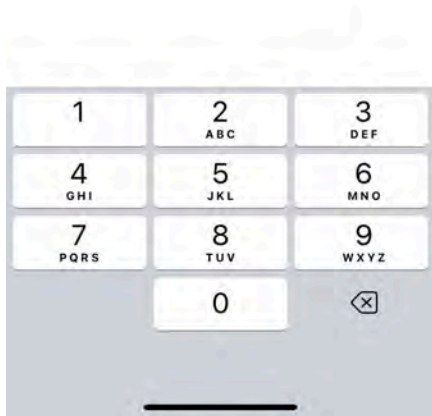

4

2.2 Please log in with your Register ID.

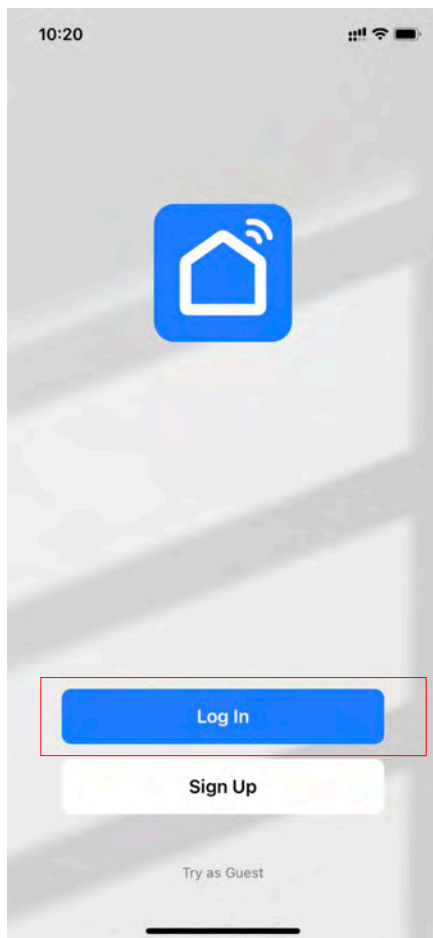

①

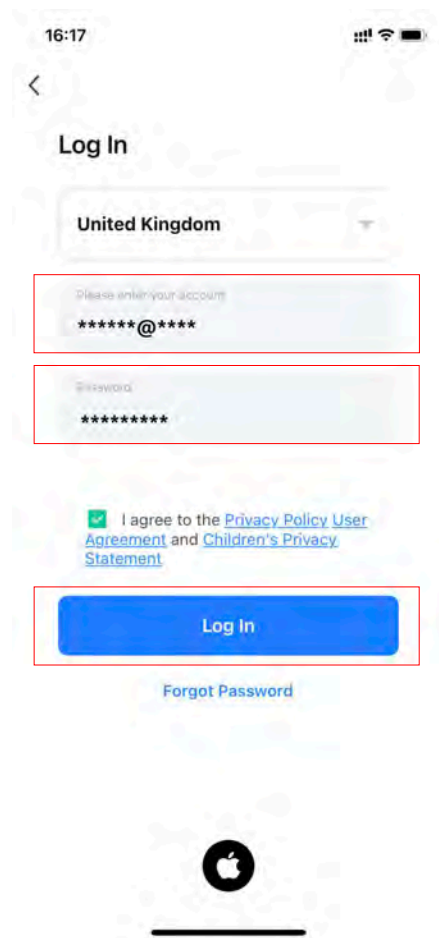

②

3. Add device

3.1 Please open the controller to operate WIFI Paring.

Press and hold the “+” and “M” keys simultaneously for 3 seconds to enter the "Default Mode" distribution network. When entering, the “” icon flashes quickly;

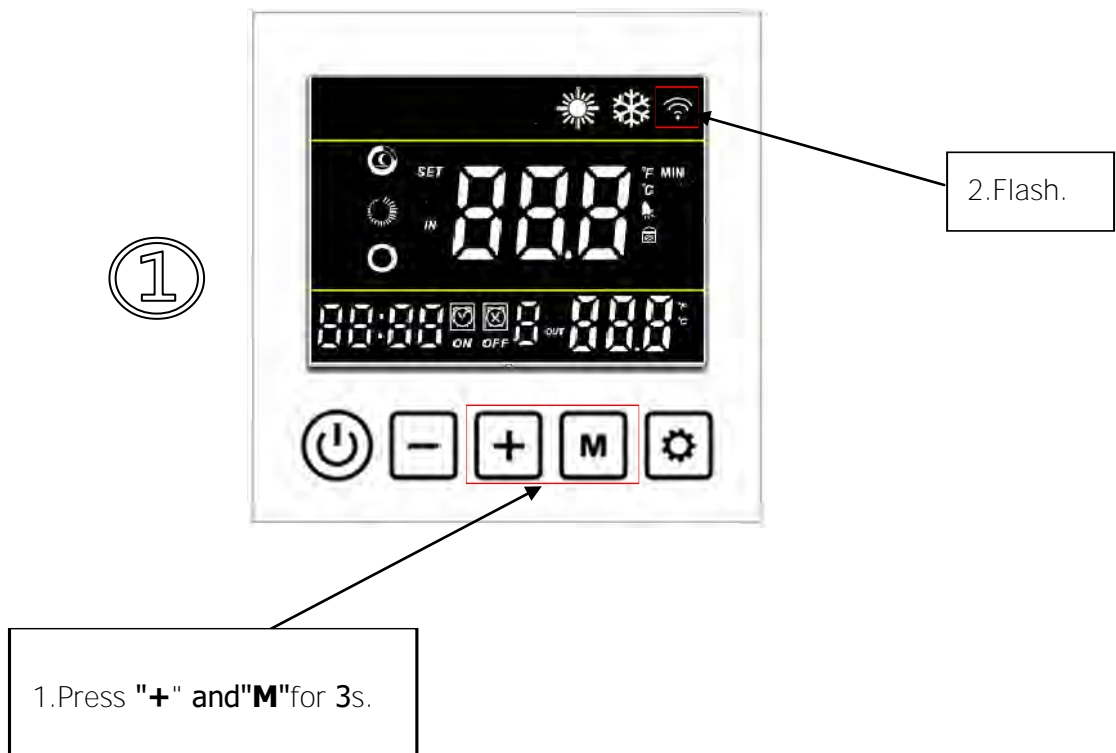

3.2 Click “Add Device” and select “Electrical” and “Switch(Wi-Fi)”to connect WIFI.

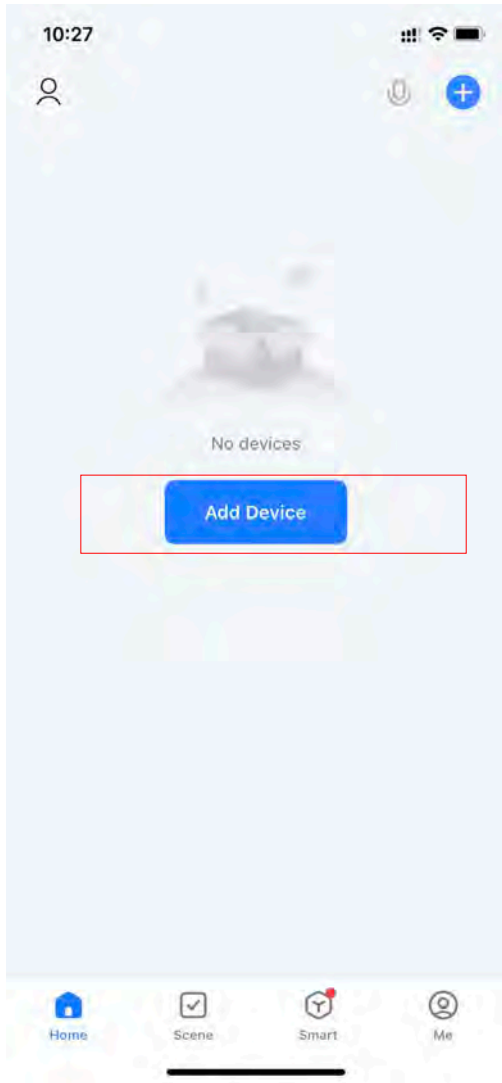

2

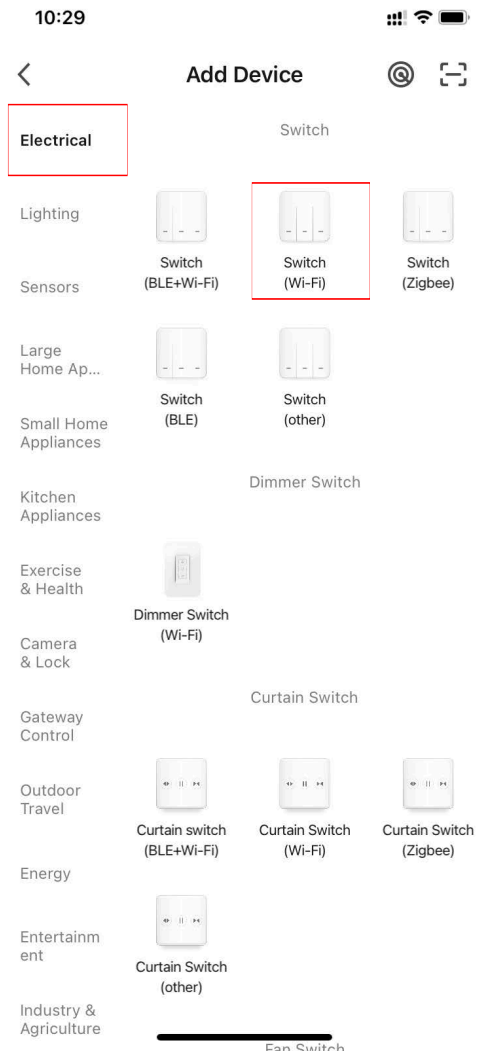

3

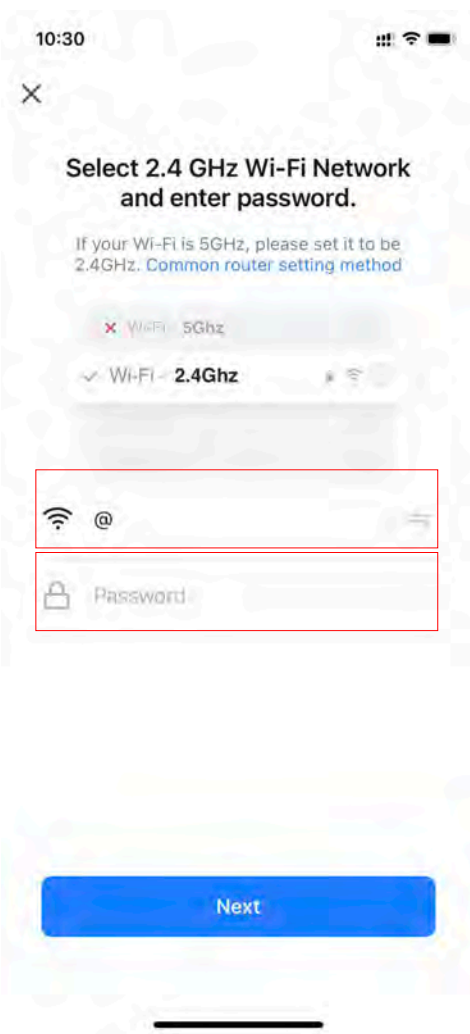

4

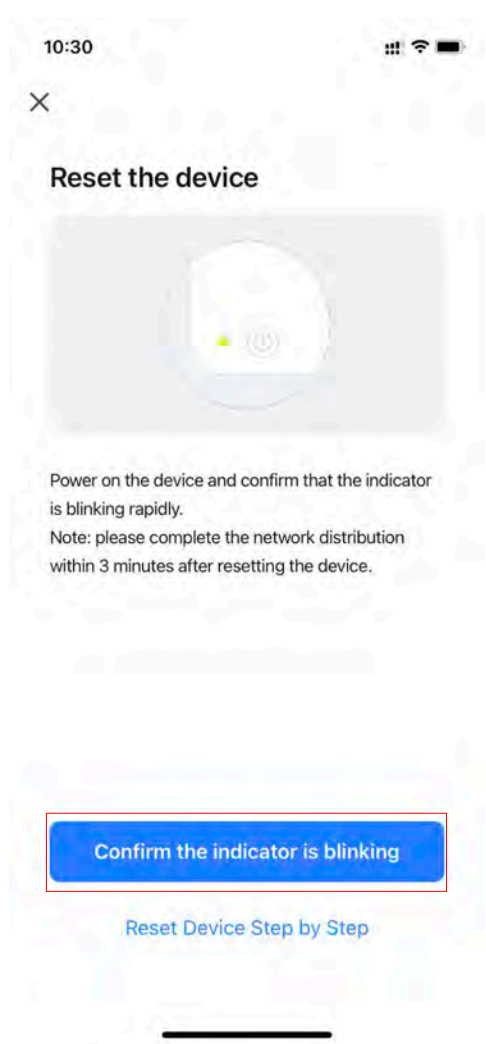

5

3.4 Input the WIFI ID and Password to search for devices.



6

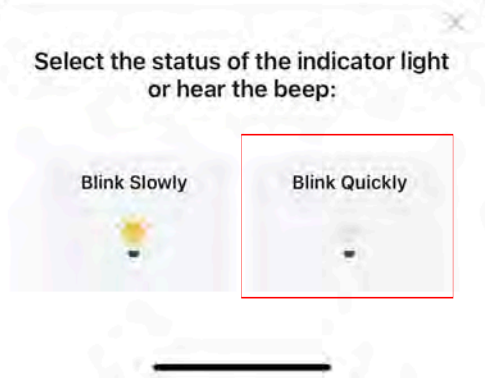

7

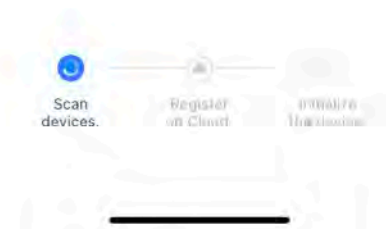
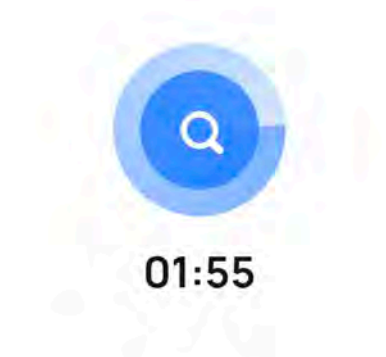

3.5 Add and connect to the device.



8



9

4. Device Management and Control.

