

POOLEX

MEGALINE **FI**

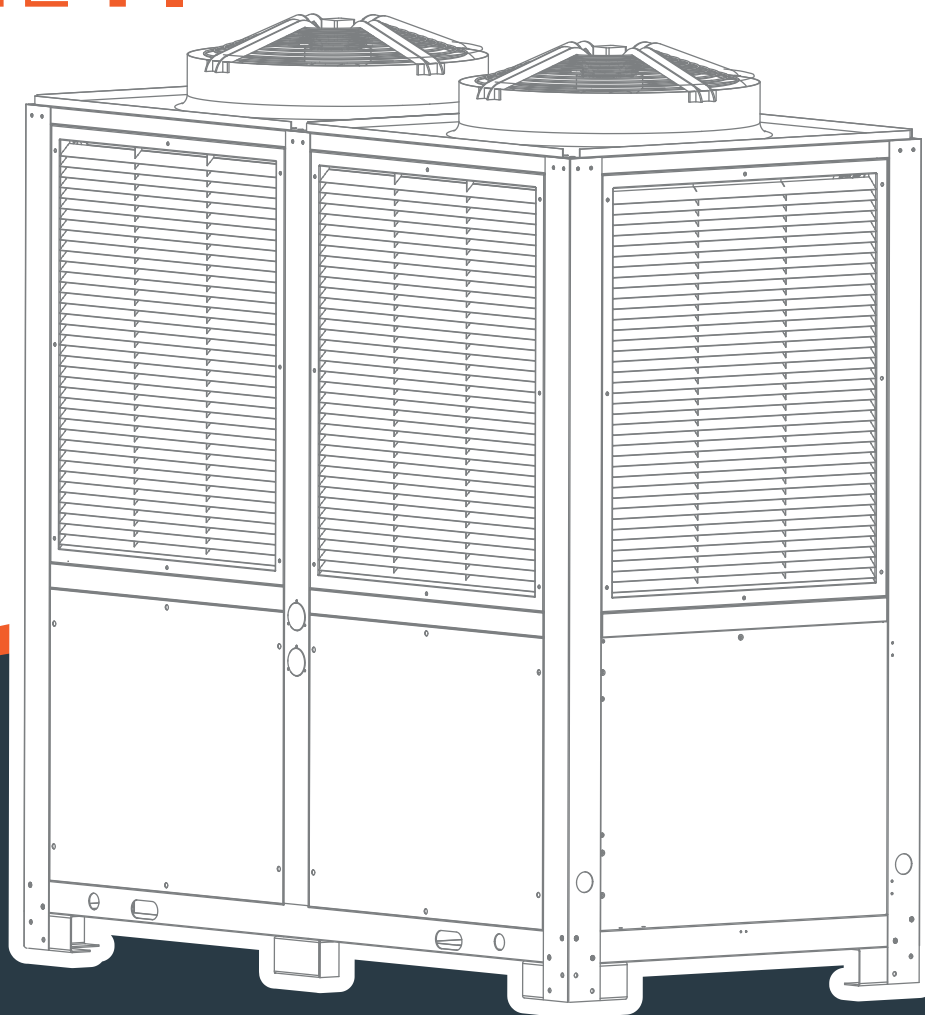

INSTALLATION AND USER MANUAL
de votre pompe à chaleur

Warning



This heat pump contains a flammable refrigerant R32.

Any intervention on the refrigerant circuit is prohibited without a valid authorization.

Before working on the refrigerant circuit, the following precautions are necessary for safe work.

1. Work procedure

The work must be carried out according to a controlled procedure, in order to minimize the risk of presence of flammable gases or vapors during the execution of the works.

2. General work area

All persons in the area must be informed of the nature of the work in progress. Avoid working in a confined area. The area around the work area should be divided, secured and special attention should be paid to nearby sources of flame or heat.

3. Verification of the presence of refrigerant

The area should be checked with a suitable refrigerant detector before and during work to ensure that there is no potentially flammable gas. Make sure that the leak detection equipment used is suitable for flammable refrigerants, ie it does not produce sparks, is properly sealed or has internal safety.

4. Presence of fire extinguisher

If hot work is to be performed on the refrigeration equipment or any associated part, appropriate fire extinguishing equipment must be available. Install a dry powder or CO2 fire extinguisher near the work area.

5. No source of flame, heat or spark

It is totally forbidden to use a source of heat, flame or spark in the direct vicinity of one or more parts or pipes containing or having contained a flammable refrigerant. All sources of ignition, including smoking, must be sufficiently far from the place of installation, repair, removal and disposal, during which time a flammable refrigerant may be released into the surrounding area. Before starting work, the environment of the equipment should be checked to ensure that there is no risk of flammability. «No smoking» signs must be posted.

6. Ventilated area

Make sure the area is in the open air or is properly ventilated before working on the system or performing hot work. Some ventilation must be maintained during the duration of the work.

7. Controls of refrigeration equipment

When electrical components are replaced, they must be suitable for the intended purpose and the appropriate specifications. Only the parts of the manufacturer can be used. If in doubt, consult the technical service of the manufacturer. The following controls should be applied to installations using flammable refrigerants:

- *The size of the load is in accordance with the size of the room in which the rooms containing the refrigerant are installed;*
- *Ventilation and air vents work properly and are not obstructed;*
- *If an indirect refrigeration circuit is used, the secondary circuit must also be checked.*
- *The marking on the equipment remains visible and legible. Illegible marks and signs must be corrected;*
- *Refrigeration pipes or components are installed in a position where they are unlikely to be exposed to a substance that could corrode components containing refrigerant*

8. Verification of electrical appliances

Repair and maintenance of electrical components must include initial safety checks and component inspection procedures. If there is a defect that could compromise safety, no power supply should be connected to the circuit until the problem is resolved.

Initial security checks must include:

- *That the capacitors are discharged: this must be done in a safe way to avoid the possibility of sparks;*
- *No electrical components or wiring are exposed during loading, recovery or purging of the refrigerant gas system;*
- *There is continuity of grounding.*

Dear Customer,

Thank you for your purchase and for your confidence in our products.

These are the result of many years of research in the field of design and production of heat pumps for swimming pools. Our aim is to provide you with an exceptional high performance quality product.

We have produced this manual with the utmost care so that you get maximum benefit from your Poolex heat pump.

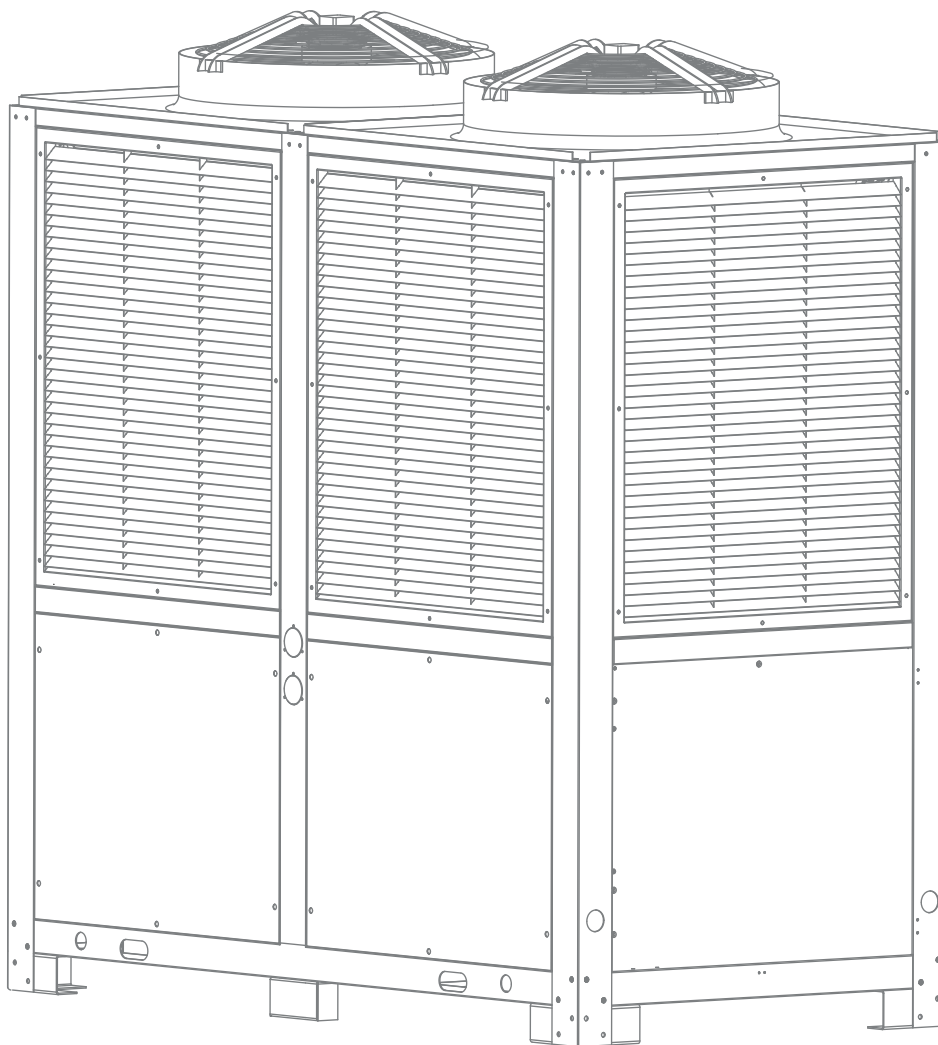



PLEASE READ CAREFULLY.



These installation instructions are an integral part of the product. They must be given to the installer and retained by the user. If the manual is lost, please consult the website:

The instructions and recommendations contained in this manual should be read carefully and understood since they provide valuable information concerning the heat pump's safe handling and operation. **Keep this manual in an accessible place for easy future reference.**

Installation must be carried out by a qualified professional person in accordance with current regulations and the manufacturer's instructions. An installation error may cause physical injury to persons or animals as well as mechanical damage for which the manufacturer can under no circumstances be held responsible.

After unpacking the heat pump, please check the contents in order to report any damage.

Prior to connecting the heat pump, ensure that the information provided in this manual is compatible with the actual installation conditions and does not exceed the maximum limits authorised for this particular product.

In the event of a defect and/or malfunction of the heat pump, the electricity supply must be disconnected and no attempt made to repair the fault. Repairs must be undertaken only by an authorised technical service organisation using original replacement parts. Failure to comply with the above-mentioned clauses may have an adverse effect on the heat pump's safe operation.

To guarantee the heat pump's efficiency and satisfactory operation, it is important to ensure its regular maintenance in accordance with the instructions provided.

If the heat pump is sold or transferred, always make sure that all technical documentation is transmitted with the equipment to the new owner.

This heat pump is designed solely for heating a swimming pool. Any other use must be considered as being inappropriate, incorrect or even hazardous.

Any contractual or non-contractual liability of the manufacturer/distributor shall be deemed null and void for damage caused by installation or operational errors, or due to non-compliance with the instructions provided in this manual or with current installation norms applicable to the equipment covered by this document.

Contents

1.	Generality	6
1.1	Terms of delivery	6
1.2	Safety instructions	6
1.3	Water treatment	7
2.	Description	8
2.1	Package Contents	8
2.2	Main Features	8
2.3	Flowsheet	8
2.4	Technical characteristics	9
2.5	Unit dimensions	10
2.6	Exploded view	11
3.	Installation	12
3.1	Prerequisites	12
3.2	Location	12
3.3	Installation Diagram	13
3.4	CONDENSATE DRAIN	13
3.5	Water connection	14
3.6	Electrical Installation	16
3.7	Electrical connection	17
4.	use	18
4.1	Control box	18
4.2	Choice of operating mode	18
4.3	Standby	19
4.4	Choice of operating mode	19
4.5	Setting the clock	19
4.6	Setting the time schedule	19
4.7	Activating the programming schedule	20
4.8	Adjusting the temperature setpoint	20
4.9	Table settings	20
4.10	Table of status	21
4.11	system settings	22
5.	Commissioning	23
5.1	Commissioning	23
5.2	Slaving a circulation pump	24
5.3	Using the gauge	24
5.4	frost protection	25
5.5	WiFi configuration	25
5.5.1	Download and install the app smart Tuya	26
5.5.2	Setting the Application	27
5.5.3	Pairing the heat pump	28
5.5.4	steering	29
6.	Maintenance and Service	31
6.1	Maintenance and Service	31
6.2	Wintering	31
7.	help	32
7.1	Faults and defects	32
7.2	error Codes	33
8.	Recycling	35
8.1	Recycling the heat pump	35
9.	Guarantee	36
9.1	Warranty Conditions	36
10.	Attachments	37
10.1	electronic card wiring diagrams	37

1. General

1.1 General Terms of Delivery

All equipment, even if shipped 'free of carriage and packing', is dispatched at the consignee's own risk

The person responsible for receiving the equipment must carry out a visual inspection to identify any damage to the heat pump during transport (refrigerant system, body panels, electrical control box, frame). He/she must note down on the carrier's delivery note any remarks concerning damage caused during transport and confirm them to the carrier by registered letter within 48 hours.

The equipment must always be stored and transported vertically on a pallet and in its original packaging. If



it is stored or transported horizontally, wait at least 24 hours before switching it on.

1.2 Safety instructions



WARNING: Please read carefully the safety instructions before using the equipment. The following instructions are essential for safety so please strictly comply with them.

During installation and servicing

Only a qualified person may undertake installation, start-up, servicing and repairs, in compliance with current standards.

Before operating or undertaking any work on the equipment (installation, commissioning, usage, servicing), the person responsible must be aware of all the instructions in the heat pump's installation manual as well as the technical specifications.

Under no circumstances install the equipment close to a source of heat, combustible materials or a building's air intake.

If installation is not in a location with restricted access, a heat pump protective grille must be fitted.

To avoid severe burns, do not walk on pipework during installation, repairs or maintenance.

To avoid severe burns, prior to any work on the refrigerant system, turn off the heat pump and wait several minutes before placing temperature and pressure sensors.

Check the refrigerant level when servicing the heat pump.

Check that the high and low pressure switches are correctly connected to the refrigerant system and that they turn off the electrical circuit if tripped during the equipment's annual leakage inspection.

Check that there is no trace of corrosion or oil stains around the refrigerant components.

1. General

During use

To avoid serious injuries, never touch the fan when it is operating.

Keep the heat pump out of the reach of children to avoid serious injuries caused by the heat exchanger's blades.

Never start the equipment if there is no water in the pool or if the circulating pump is stopped.

Check the water flow rate every month and clean the filter if necessary.

During cleaning

Switch off the equipment's electricity supply.

Close the water inlet and outlet valves.

Do not insert anything into the air or water intakes or outlets.

Do not rinse the equipment with water.

During repairs

Carry out work on the refrigerant system in accordance with current safety regulations.

Brazing should be performed by a qualified welder.

When replacing a defective refrigerant component, use only parts certified by our technical department.

When replacing pipework, only copper pipes conforming to Standard NF EN12735-1 may be used for repairs.

When pressure-testing to detect leaks:

To avoid the risks of fire or explosion, never use oxygen or dry air.

Use dehydrated nitrogen or a mixture of nitrogen and refrigerant.

The low and high side test pressure must not exceed 42 bar.

1.3 Water treatment

Poolex heat pumps for swimming pools can be used with all types of water treatment systems.

Nevertheless, it is essential that the treatment system (chlorine, pH, bromine and/or salt chlorinator metering pumps) is installed after the heat pump in the hydraulic circuit.

To avoid any deterioration to the heat pump, the water's pH must be maintained between 6.9 and 8.0.

2. Description

2.1 Package contents

- ✓ Heat pump Poolex Poolex Megaline Fi
- ✓ This installation and user manual

2.2 General characteristics

A Poolex heat pump has the following features:

- ▶ CE and TÜV certification and complies with the RoHS European directive.
- ▶ High performance with up to 80% energy savings compared to a conventional heating system.
- ▶ Clean, efficient and environmentally friendly R32 refrigerant.
- ▶ Reliable high output leading brand compressor.
- ▶ Wide hydrophilic aluminium evaporator for use at low temperatures.
- ▶ User-friendly intuitive remote control.
- ▶ Designed to be silent.
- ▶ Dual antifreeze system to avoid frost damage:

Revolutionary exchanger with patented antifreeze system.

A smart monitoring system to preserve the pipework and liner without emptying the pool in winter.

2.3 Operating diagram

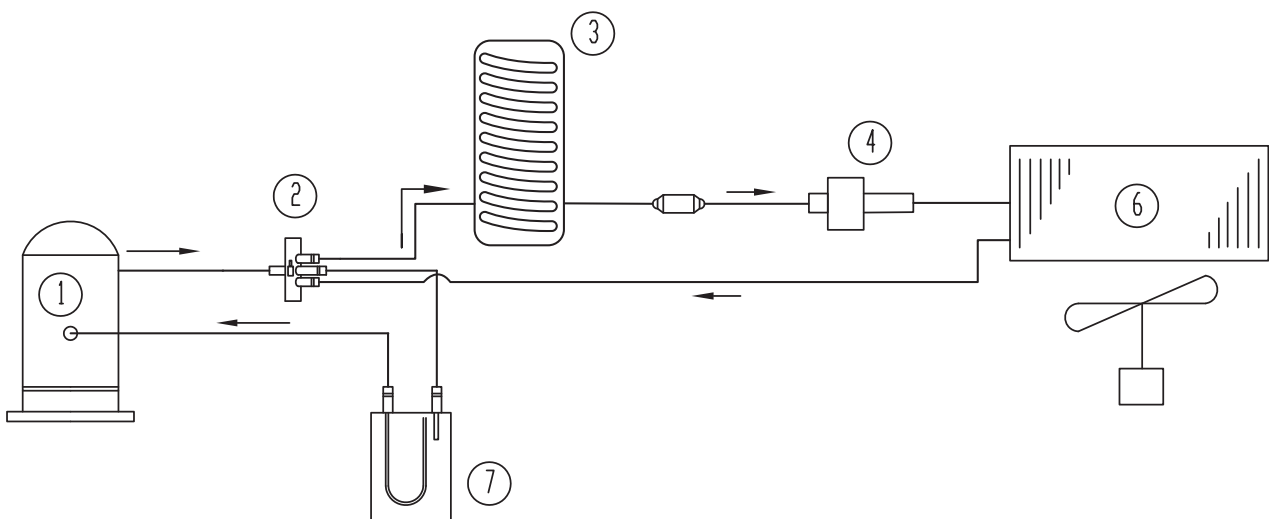

- | | |
|-------------------------------|-----------------------------------|
| 1. Compressor | 5. Fan |
| 2. 4 way valve | 6. evaporator |
| 3. Heat exchanger | 7. Gas / liquid separation bottle |
| 4. Electronic expansion valve | |

2. Description

2.4 technical characteristics

		Poolex Megaline Fi		
Reference : PC-MLP		502N	752N	1002N
Air 26°C Eau 26°C Hygro 80%	Max. Heating power (kW)	68	102	135
	Min. Heating power (kW)	16,1	24,3	31,9
	Consumption (kW)	9.8~1.2	14.7~1.8	19.3~2.3
	COP	13.54~6.93	13.56~6.95	13.59~6.98
Air 15°C Eau 26°C Hygro 70%	Max. Heating power (kW)	50	75	100
	Min. Heating power (kW)	11,7	17,8	23,6
	Consumption (kW)	10.1~1.6	15.1~2.4	20.0~3.1
	COP	7.52~4.93	7.55~4.96	7.58~4.99
Air 6°C Eau 26°C	Max. Heating power (kW)	45	67	90
	Min. Heating power (kW)	10,2	15,3	20,5
	Consumption (kW)	11.4~1.7	16.9~2.6	22.6~3.5
	COP	5.84~3.96	5.85~3.97	5.88~3.99
Air 35°C Eau 27°C	Max. Heating power (kW)	37	55	74
	Min. Heating power (kW)	9,1	13,5	18,1
	Consumption (kW)	10.2~1.4	15.1~2.0	20.3~2.7
	EER	6.67~3.63	6.68~3.64	6.71~3.65
Electricity supply	TRI 380-415V/3N~50Hz			
Heating temperature range	15°C~40°C			
Operating temperature range	-15°C~43°C			
Maximum power (kW)	14,9	22,4	29,8	
Maximum current (A)	27	39	53	
Minimum flow (m³/h)	10	15	20	
Optimal flow (m³/h)	20	30	40	
Max flow (m³/h)	30	35	60	
Refrigerant	R32			
Refrigerant Charg	4.5kg	2.6kg + 2.6kg	4.5kg + 4.5kg	
Unit dimensions L x W x H (mm)	1448x800x950.5	1252x1076x1865	2148x1076x2176	
Unit weight (kg)	280	450	760	
Sound pressure level at 1m (dBA) ⁽³⁾	<70	<72	<74	
Sound pressure level at 4m (dBA) ⁽³⁾	<58	<60	<62	
Sound pressure level at 10m (dBA) ⁽³⁾	<50	<52	<54	
Pressure mini / Max (MPa)	0.2/4.4	0.2/4.4	0.2/4.4	
Hydraulic connection (mm)	63	75	75	
Compressor type	Rotatif Inverter			
Number of compressors	1	2	2	
Compressor brand	Mitsubishi inverter rotate			
Heat exchanger	Cuve PVC et Titanium coil			
Fonction	Heating Inverter / Cooling Inverter / Silent / Auto			
Pertes en charge (mCE)	4	4,2	4,8	

The technical specifications of our heat pumps are provided for information purposes only. We reserve the right to make changes without prior notice.

¹ Ambient air temperature

² Initial water temperature

³ Noise at 1 m, at 4 m and at 10 m in accordance with Directives EN ISO 3741 and EN ISO 354

2. Description

2.5 Unit dimensions

Megaline Fi 50

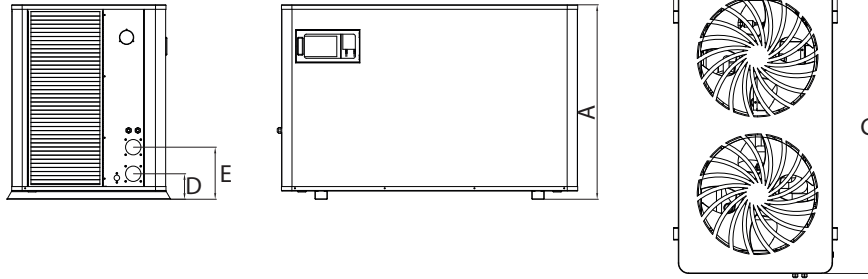

Megaline Fi 50 / 75

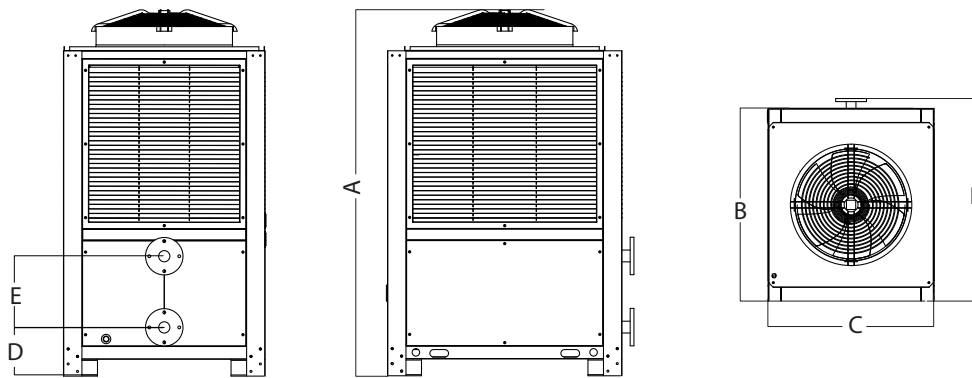

Megaline Fi 100

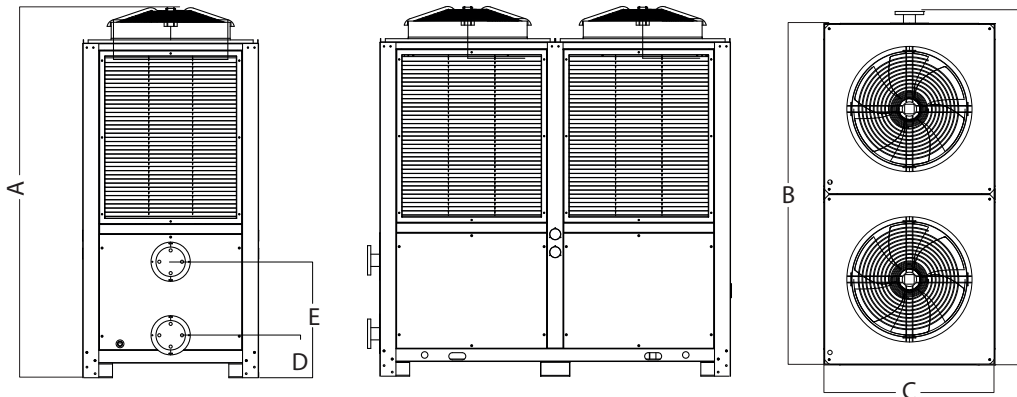

Dimensions en mm

Modèle	Megaline Fi 50	Megaline Fi 75	Megaline Fi 100
A	950.5	1955	2265
B	754	1252	2148
C	1448	1076	1076
D	124.5	170	260
E	254.5	380	450
F	800	1316	2224

2. Description

2.6 exploded view

Megaline Fi 50

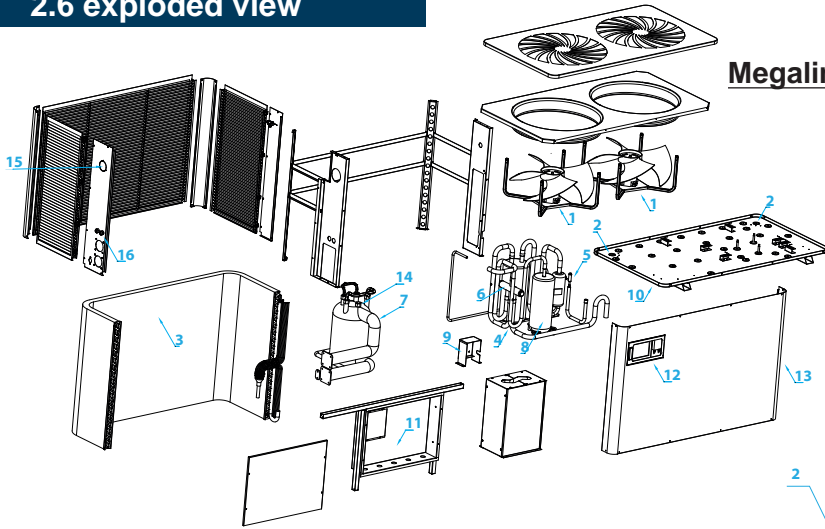

Megaline Fi 75

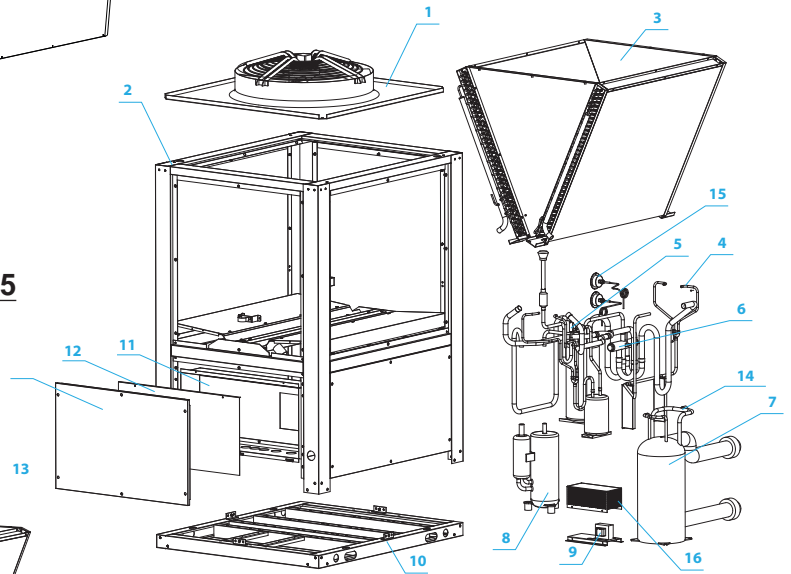

Megaline Fi 100

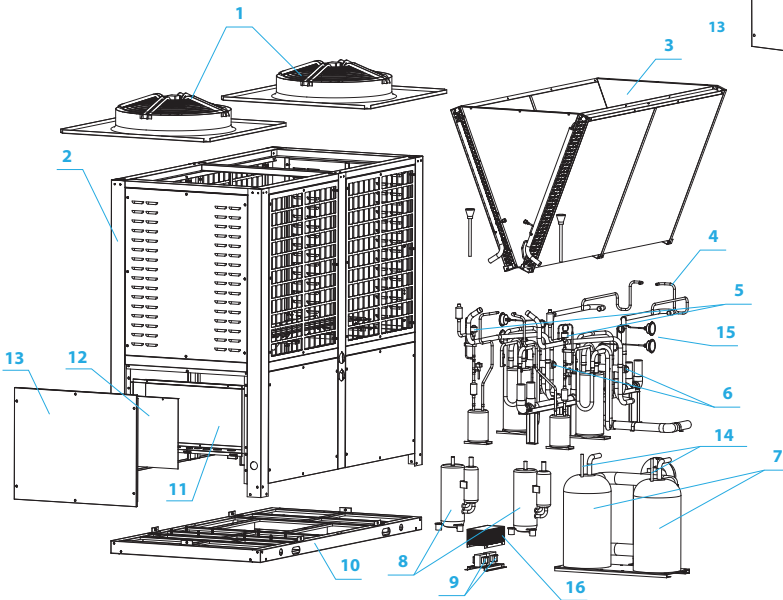

- | | |
|-------------------------------|-------------------------------|
| 1. Fan and motor | 9. Electric transformer |
| 2. Base frame | 10. Bottom panel |
| 3. Evaporator | 11. Logic board box |
| 4. gas pipe | 12. Electrical box cover |
| 5. Electronic expansion valve | 13. Front panel |
| 6. 4-way valve | 14. Water Flow Switch |
| 7. Heat exchanger | 15. Pressure gauge |
| 8. Compressor | 16. Electrical terminal block |

3. Installation



WARNING: Installation must be carried out by a qualified engineer. This section is provided for information purposes only and must be checked and adapted if necessary according to the actual installation conditions.

3.1 Pre-requirements

Equipment necessary for the installation of your heat pump:

Power supply cable suitable for the unit's power requirements.

A By-Pass kit and an assembly of PVC tubing suitable for your installation as well as stripper, PVC adhesive and sandpaper.

Suitable concrete pads can be used to raise the device.

3.2 Location

Please comply with the following rules concerning the choice of heat pump location.

1. The unit's future location must be easily accessible for convenient operation and maintenance.
2. It must be installed on the ground, fixed ideally on a level concrete floor. Ensure that the floor is sufficiently stable and can support the weight of the unit.
3. A water drainage device must be provided close to the unit in order to protect the area where it is installed.
4. If necessary, the unit may be raised by using suitable mounting pads designed to support its weight.
5. Check that the unit is properly ventilated, that the air outlet is not facing the windows of neighbouring buildings and that the exhaust air cannot return. In addition, provide sufficient space around the unit for servicing and maintenance operations.
6. The unit must not be installed in an area exposed to oil, flammable gases, corrosive products, sulphurous compounds or close to high frequency equipment.
7. To prevent mud splashes, do not install the unit near a road or track.
8. To avoid causing nuisance to neighbours, make sure the unit is installed so that it is positioned towards the area that is least sensitive to noise.
9. Keep the unit as much as possible out of the reach of children.

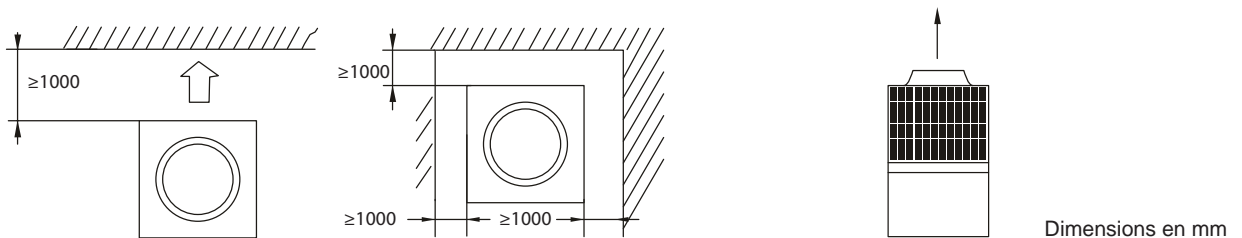

Do not put anything less than one meter in front of the heat pump.

Leave 100 cm of empty space on the sides and back of the heat pump and free ventilation above

Do not leave any obstacles above or in front of the device!

3. Installation

3.3 Installation layout

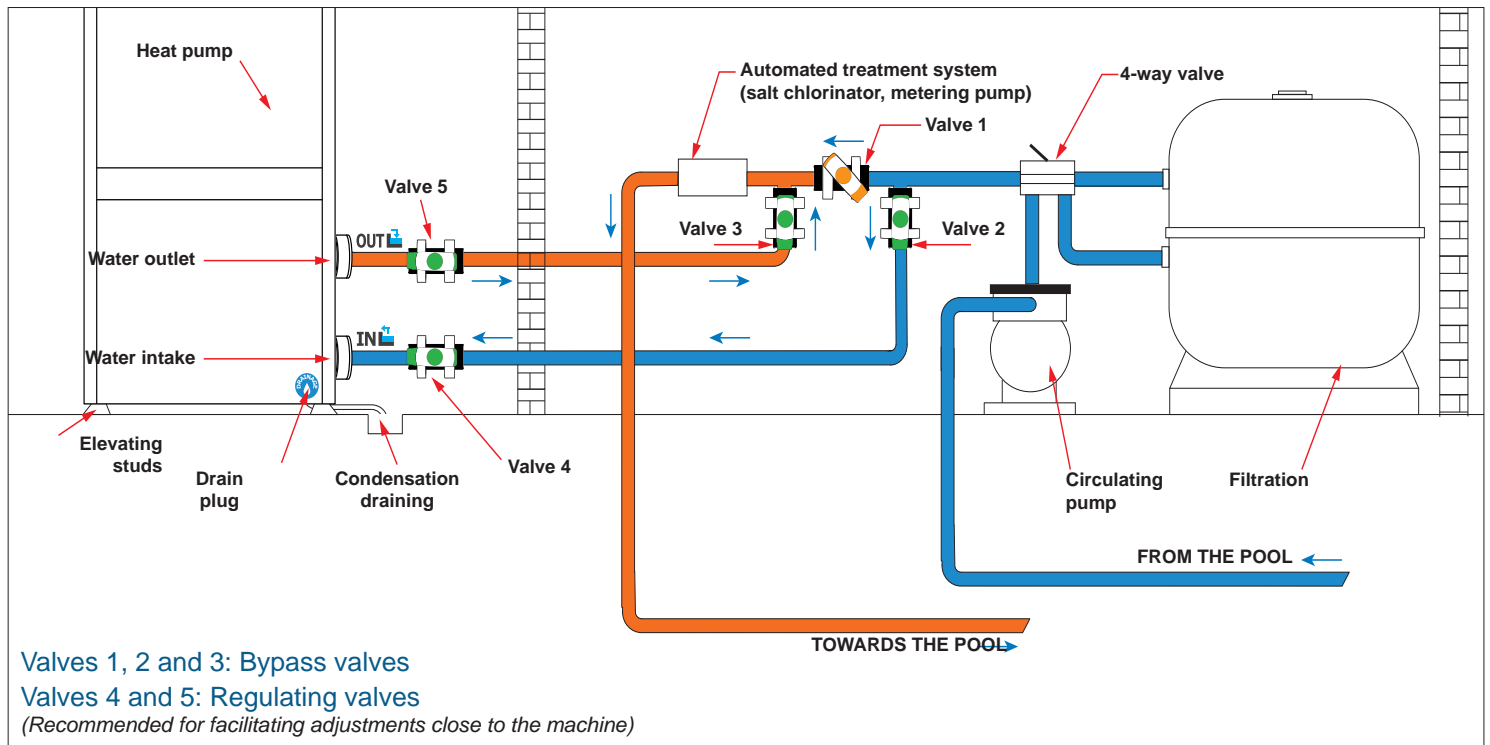

3.4 Connecting the condensation draining kit

While operating, the heat pump is subject to condensation. This will result in a more or less large run-off of water, depending on the degree of humidity. To channel this flow, we recommend that you install the condensation drainage kit.

For optimal condensate drainage, it is imperative that the device is horizontal.

3. Installation



WARNING: Installation must be carried out by a qualified engineer. This section is provided for information purposes only and must be checked and adapted if necessary according to the actual installation conditions.

3.6 Hydraulic connection

By-Pass assembly

The heat pump must be connected to the pool by means of a By-Pass assembly.

A By-Pass is an assembly consisting of 3 valves that regulate the flow circulating in the heat pump. During maintenance operations, the By-Pass permits the heat pump to be isolated from the system without interrupting your installation.

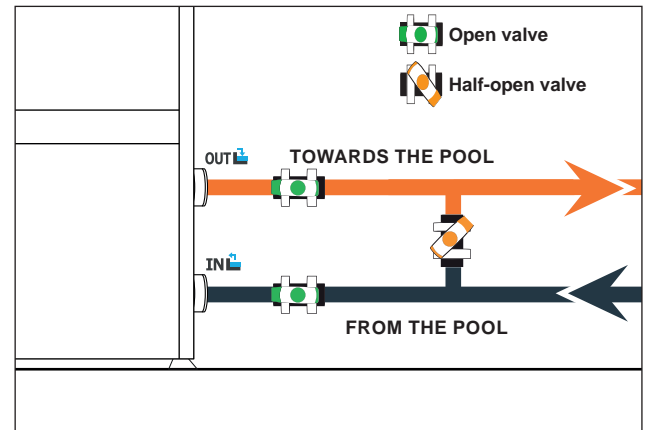

Making a hydraulic connection with the By-Pass kit



WARNING: Do not run water through the hydraulic circuit for 2 hours after applying the adhesive.

- Step 1: Take the necessary steps to cut your pipes.
- Step 2: Make a straight perpendicular cut through the PVC pipes with a saw.
- Step 3: Assemble your hydraulic circuit without connecting it in order to check that it perfectly fits your in-

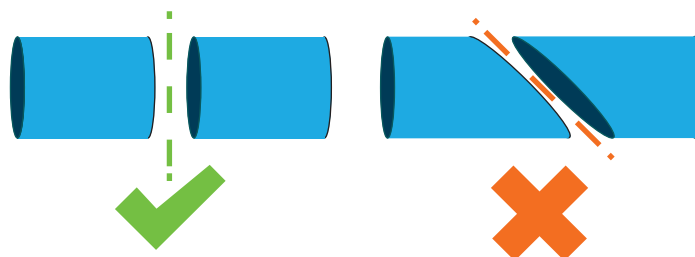

stallation, then dismantle the pipes to be connected.

- Step 4: Chamfer the ends of the cut pipes with sandpaper.
- Step 5: Apply stripper to the ends of the pipes to be connected.
- Step 6: Apply the adhesive in the same place.
- Step 7: Assemble the pipes.
- Step 7: Clean off any adhesive remaining on the PVC.
- Step 8: Leave to dry for at least 2 hours before putting the hydraulic circuit into water.

3. Installation

By-Pass assembly for one heat pump

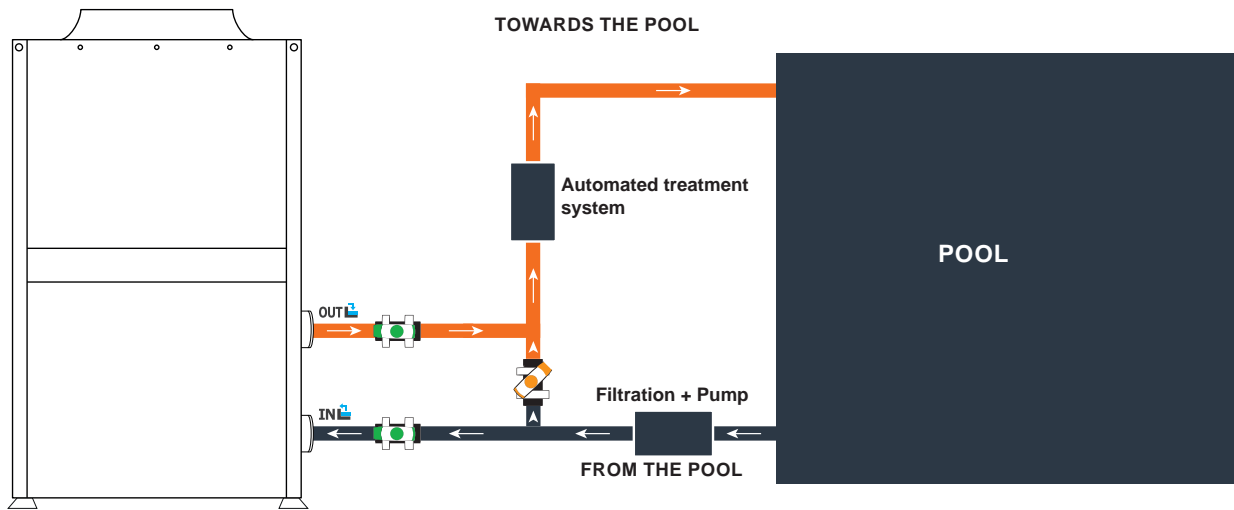

By-Pass assembly for more than one heat pump

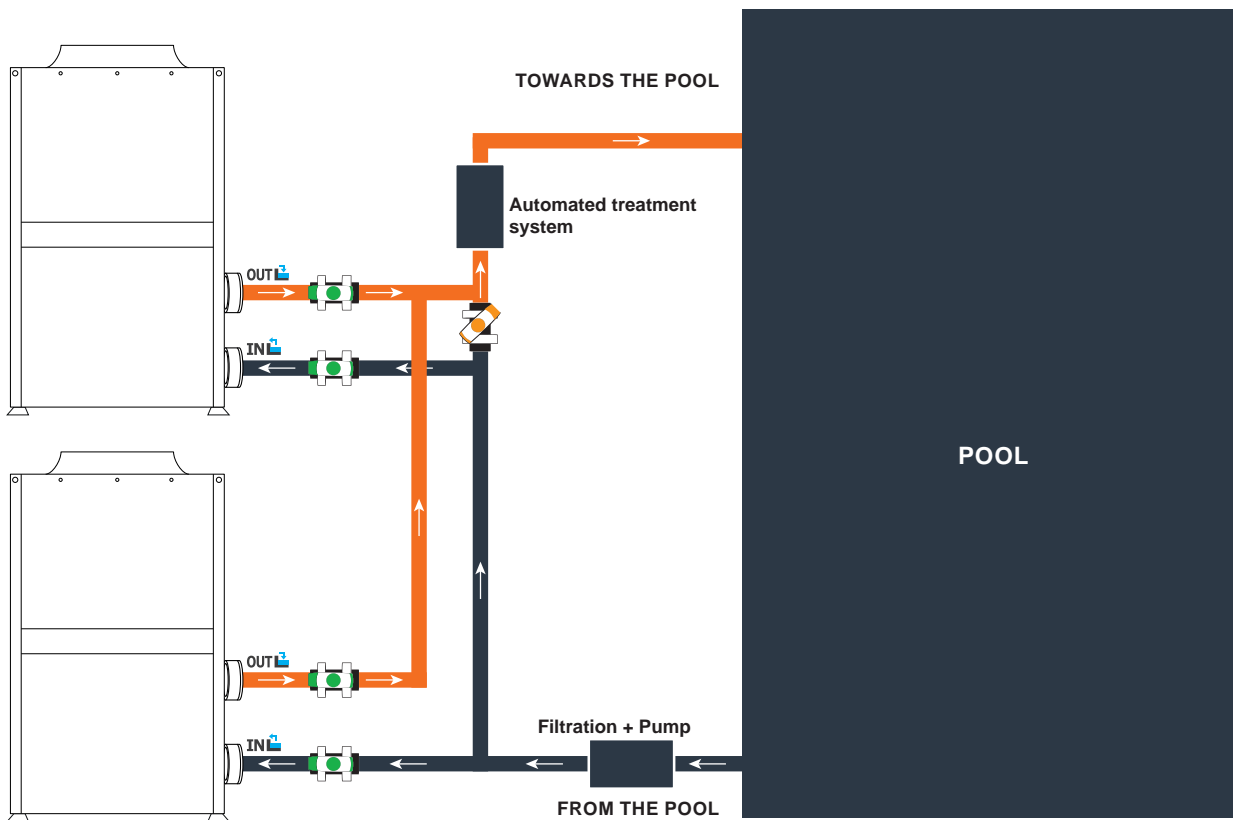

The filter located upstream of the heat pump must be regularly cleared so that the water in the system is clean, thus avoiding the operational problems associated with dirt or clogging in the filter.

3. Installation



WARNING: Installation must be carried out by a qualified engineer.
This section is provided for information purposes only and must be checked and adapted if necessary according to the actual installation conditions.

3.7 Electrical installation

To function safely and maintain the integrity of your electrical system, the unit must be connected to a general electricity supply in accordance with the following regulations:

Upstream, the general electricity supply must be protected by a 30 mA differential switch.

The heat pump must be connected to a suitable D-curve circuit breaker (see table below) in accordance with current standards and regulations in the country where the system is installed.

The electricity supply cable must be adapted to match the unit's rated power and the length of wiring required by the installation (see table below). The cable must be suitable for outdoor use.

For a three-phase system, it is essential to connect the phases in the correct sequence. If the phases are inverted, the heat pump's compressor will not work.

In places open to the public, it is mandatory to install an emergency stop button close to the heat pump.

The appliance is equipped with an antifreeze system. Do not cut off the power supply so that the antifreeze system can start.

¹ Cable cross-section suitable for max. length 10 metres. For longer than 10 metres, consult an electrician.

Models	Electricity supply	Max. current	Cable diameter	Protection Thermal-magnetic (D curve) protection
Megaline FI 50	Triphasé 380-415V/3N~50Hz	27 A	RO2V 5x 6mm ²	32A
Megaline FI 75		39 A	RO2V 5x 10mm ²	40A
Megaline FI 100		53 A	RO2V 5x 16mm ²	60A

3. Installation

3.7 Raccordement électrique



WARNING: The heat pump's power supply MUST be disconnected before any operation.

lease comply with the following instructions to electrically connect the heat pump.

Step 1: Detach the electrical side panel with a screwdriver to access the electrical terminal block.

Step 2: Insert the cable into the heat pump unit by passing it through the opening provided for that purpose.

Step 3: Connect the power supply cable to the terminal block in accordance with the diagram below.

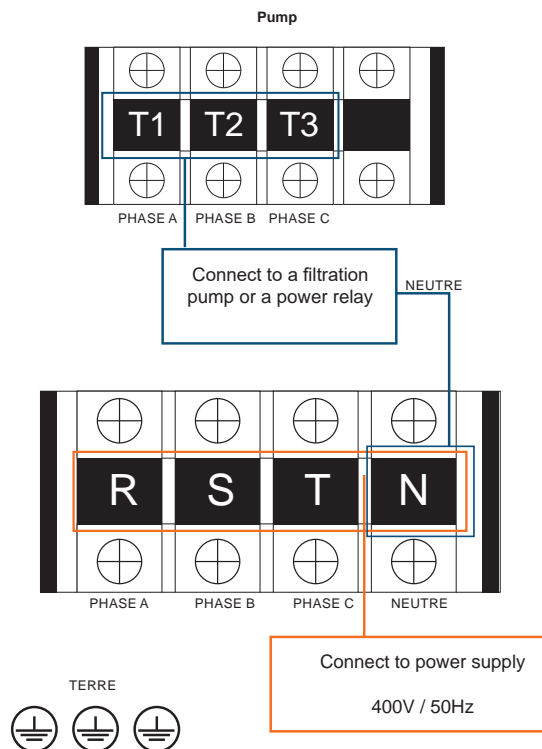

CAUTION: 400V power supply, Recover the earth on the power supply terminal block

Step 4: Carefully close the heat pump panel.

Servo-control of circulating pump

Depending on the type of installation, you can also connect a circulating pump so that this operates in tandem with the heat pump.



WARNING: Servo-control of a pump whose power exceeds 5A (1000W) requires the use of a power relay.

4. Use

4.1 Wired remote control

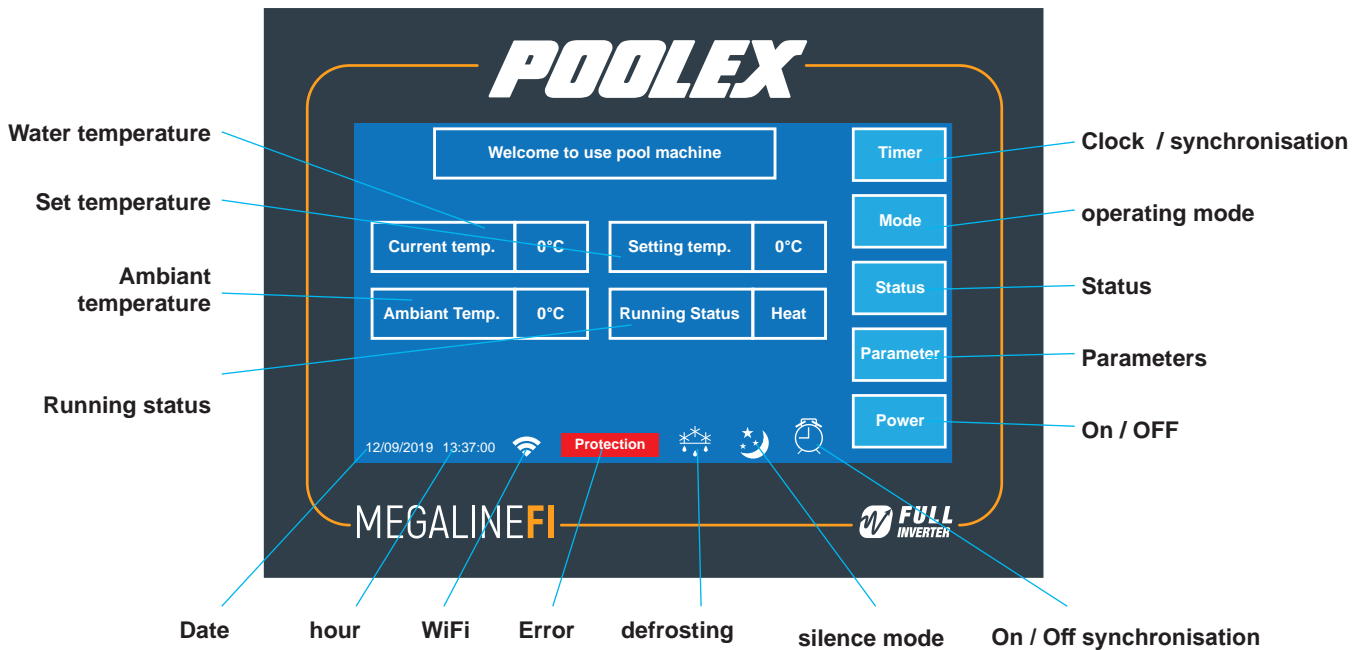

4.2 Operating mode selector



Before you start, make sure the filter pump is running and water is flowing through the heat pump.

Before setting your target temperature, you must first choose the operating mode of your heat pump:

Heat



SILENT Heating mode:

Choose this heating mode so that the heat pump operates silently.

Heat

ECO Heating mode:

Choose this heating mode for the heat pump to operate in a conventional manner.

Heat



BOOST heating mode:

Choose this heating mode so that the heat pump quickly heats the water in your pool.

Auto

Auto mode:

The heat pump intelligently chooses the most appropriate operating mode according to the setpoint temperature.

Cool



SILENT Cooling mode:

Choose this cooling mode for the heat pump to operate silently.

Cool

ECO Cooling mode:

Choose this cooling mode so that the heat pump operates in a conventional manner.

Cool



BOOST Cooling mode:

Choose this cooling mode for the heat pump to operate in a classic way.

4. Use

4.3 Stand-by

When the control panel is off: Press the screen once to turn it on.

When the control panel is unlocked and no action is taken for 1 minute, the control panel automatically turns off.

4.4 Choice of operating mode

Step 1: Go to the main menu by unlocking the control panel.

Step 2: Press the Mode button to change the working mode

Mode

4.5 Clock setting

Step 1: In the main panel, tap on the clock at the bottom left of the screen.

Step 2: Enter the current time and date.

Step 3: Return to the main screen to validate the change.

12/09/2019 13:37:00

4.6 Setting the time schedule

Step 1: Go to the main menu by unlocking the control panel.

Step 2: Press Timer to enter the setting of the On / off groups.

Step 3: Configure the start and stop times for 1 or two groups of times.

Press OK then return to the menu

When programming is activated, the following pictogram is displayed on the main page.

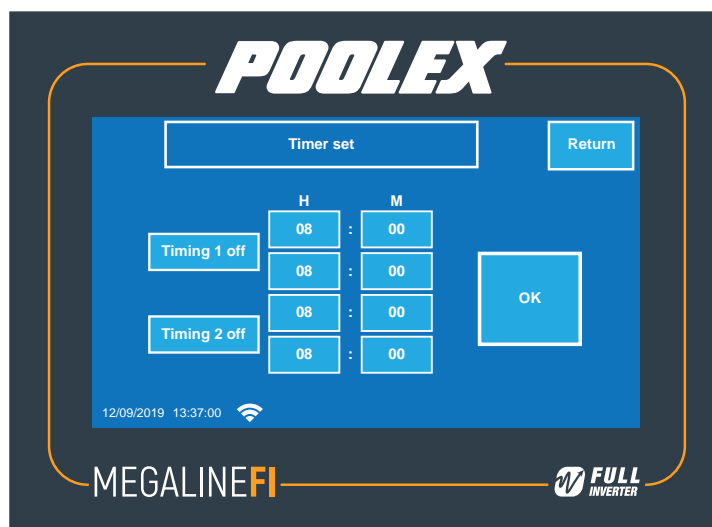

4. Use

4.7 On / Off synchronisation

Step 1: Go to the main menu by unlocking the control panel.

Step 2: Press Timer 1 On / Off to activate or deactivate a schedule.

4.8 Adjusting the setpoint temperature

Step 1: Go to the main menu by unlocking the control panel.

Step 2: Press "Setting Temp." to change the desired temperature.

Step 3: Press + or - to change the set temperature

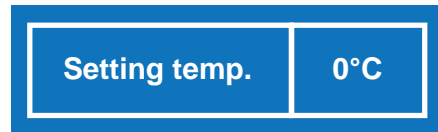

4.9 Parameter setting

Step 1: Go to the main menu by unlocking the control panel.

Step 2: Press the «Parameter» button to access the various parameters

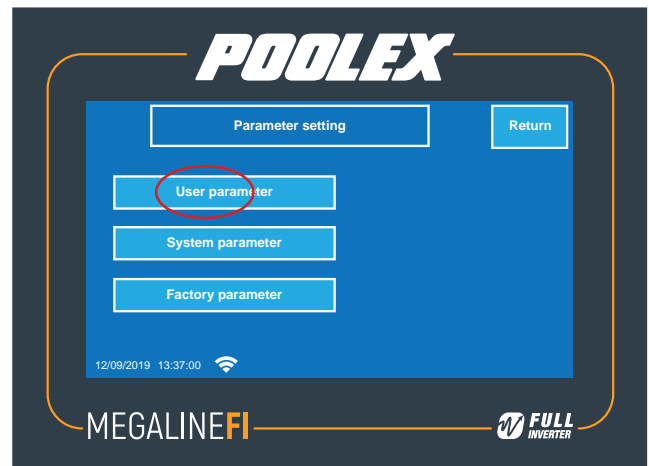
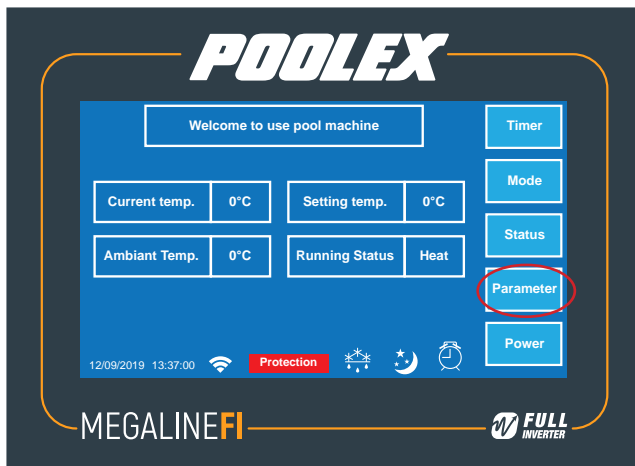

Code	value	Description	Setting range	Factory setting
P05	Heating Setting Temp.	Heating temperature adjustment	8°C ~ 28°C	27°C
P04	Cooling Setting Temp.	Adjusting the cooling temperature	15°C ~ 40°C	27°C
P01	Hystersis Temp.	Setting the trigger temperature delta	1°C ~ 18°C	1°C
P28	Pump Mode	Control of the filtration pump	0=stop; 1=Non-stop	0

4. Use

4.10 Status table

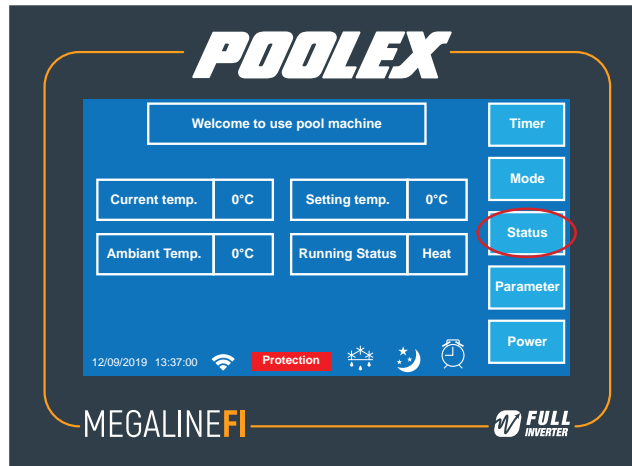

Code		Description
Current Temp.	Water inlet temperature	-30~99°C
Outlet Temp.	Water outlet temperature	-30~99°C
Ambient Temp.	Air temperature	-30~99°C
1#Exhaust Temp.	Compressor 1 outlet temperature	0~125°C
1#Suction Temp.	Compressor 1 inlet temperature	-30~99°C
1#Coil Temp.	Heat exchanger inlet temperature 1	-30~99°C
1#Inside Coil Temp.	Heat exchanger outlet temperature 1	-30~99°C
1#Opening of EEV	Opening of electronic valve 1	
1# Fan Speed	Fan speed 1	
1#Comp. Cur.	Compressor speed 1	
1#Fin Temp.	Heat exchanger outlet temperature 1	
1#DC Voltage	DC power supply voltage 1	
1#Operating Freq	Operating frequency 1	
2# Fan Speed	Fan speed 2	
2#Exhaust Temp.	Compressor 2 outlet temperature	0~125°C
2#Suction Temp.	Compressor 2 inlet temperature	-30~99°C
2#Coil Temp.	Heat exchanger 2 inlet temperature	-30~99°C
2#Inside Coil Temp.	Exchanger 2 outlet temperature	-30~99°C
2#Opening of EEV	Opening of electronic valve 2	
2#Comp. Cur.	Compressor speed 2	
2#Fin Temp.	Exchanger 2 outlet temperature	
2#DC Voltage	DC power supply voltage 2	
2#Operating Freq	Operating frequency 2	

4. Use

4.11 System parameters

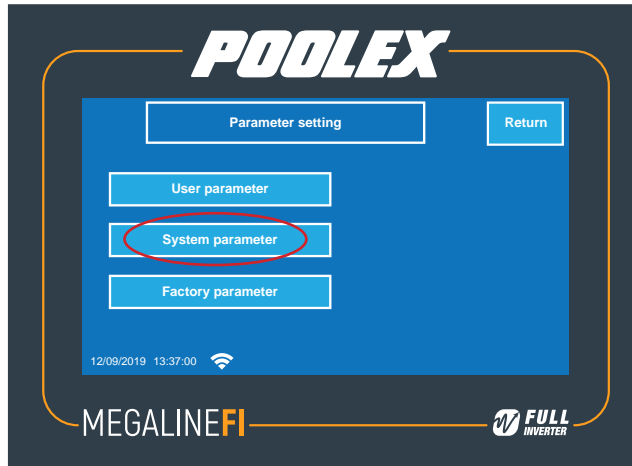

	Code	Description
P06	Exhaust Temp. Too High	Compressor outlet temperature too high
P07	Exhaust Recover Temp.	
P09	Compensated Temp.	Adjustment of the coeff. temperature probe compensation
P11	Defrost Intervals	Auto-activation time before the start of defrost
P12	Defrost Temp.	Defrost activation temperature
P13	Defrosting Max Time	Maximum defrost duration
P14	Exit Defrosting Temp.	Defrost deactivation temperature
P15	Defrost A_C □T	
P16	Defrost Ambient Temp.	
P17	EEV Cycle	
P18	Heating Overheat	Overheating (heating mode)
P19	Adjust EEV Temp.	Opening temperature of the expansion valve
P20	Defrost EEV Opening	Opening of the defrost mode expansion valve
P21	EEV minimum opening	Minimum opening of the expansion valve
P22	EEV Mode	Selection of the expansion valve mode
P23	EEV Manual Steps	Manual step expansion valve
P24	Cooling Overheat	Overheating (cooling mode)
P27	Cooling EEV Mode	operating mode of the expansion valve (cooling mode)
	Lamp Panel Display	Backlight

5. Operation

5.1 Operation

Conditions of use

For the heat pump to operate normally, the ambient air temperature must be between -15°C and 43°C.

Recommendations prior to start-up

Before activating the heat pump, please:

1. Check that the unit is firmly secured and stable.
2. Check that the gauge indicates a pressure greater than 80 psi.
3. Check that the electrical wiring is properly connected to the terminals.
4. Check the earthing.
5. Check that the hydraulic connections are tight and that there is no leakage of water.
6. Check that the water is circulating correctly in the heat pump and that the flow rate is adequate.
7. Remove any unnecessary object or tool from around the unit.

Operation

1. Activate the unit's power supply protection (differential switch and circuit-breaker).
2. Activate the circulating pump if it is not servo-controlled.
3. Check the By-Pass opening and the control valves.
4. Activate the heat pump
5. Adjust the remote control clock.
6. Select the required temperature by using one of the remote control's mode.
7. The heat pump's compressor will start up after a few moments.

All you have to do now is wait until the required temperature is reached.



WARNING: Under normal conditions, a suitable heat pump can heat the water in a swimming pool by 1°C to 2°C per day. It is therefore quite normal to not feel any temperature difference in the system when the heat pump is working. A heated pool must be covered to avoid any loss of heat.

5. Operation

5.2 Servo-control of circulating pump

To use the servo mode, check that parameter 28 is set to 1.

If you have connected a circulation pump to terminals U, V and W (400V), this is automatically supplied when the heat pump is running.

When the heat pump is on standby, the circulation pump is supplied intermittently in order to control the temperature of the pool water.

Control mode of the circulation pump

When you turn on your heat pump, the circulation pump starts up and then 1 minute later, the heat pump compressor activates. When the heat pump stops working, its compressor and fan shut off, then after 30 seconds, the circulation pump shuts off. During a defrost cycle, the circulation pump will continue to operate regardless of the mode selected.

Mode 0: By choosing this mode, the heat pump will automatically start the circulation pump continuously. Once the circulation pump is running, the heat pump will start up 1 minute later. Then, when the set temperature is reached, the heat pump will stop its function but will not stop the circulation pump so that it ensures constant water circulation in your heat pump.

Mode 1 (default): This mode has been designed to maintain the filtration of your pool without using the time slot programmer. When the set temperature is reached, the heat pump will go into standby, then after 30 seconds, the circulation pump will stop.

Then the circulation pump will be reactivated in special mode: 2 minutes on, 60 minutes off.

A temperature sensor, being placed in the heat exchanger compartment, this mode allows your heat pump to update the actual temperature of your pool every 60 minutes. This mode is therefore recommended.

It is only when the pool temperature drops by 1 ° C from the setpoint temperature, that the filtration pump and the heat pump will resume their normal operating mode.

5.3 Using the pressure gauge

The manometer is used to control the pressure of the refrigerant contained in the heat pump.

The values it indicates can be very different depending on the climate, temperature and atmospheric pressure.

When the heat pump is running:

The pressure gauge needle indicates the pressure of the refrigerant.

Average range of use between 250 and 400 PSI depending on ambient temperature and atmospheric pressure.

When the heat pump is off:

The needle indicates the same value as the ambient temperature (within a few degrees) and the corresponding atmospheric pressure (between 150 to 350 PSI maximum).

After a long period of non-use:

Check the pressure gauge before restarting the heat pump. This should read at least 80 PSI.

If the pressure in the manometer becomes too low, the heat pump will indicate an error message and automatically go into safety.

This means that a refrigerant leak has occurred and you must call a qualified technician to recharge it.

5. Operation

5.4 Antifreeze protection



WARNING: For the antifreeze system to work, the heat pump must be powered and the circulating pump activated. If the circulating pump is servo-controlled by the heat pump, it will be automatically activated.

When the heat pump is on standby, two antifreeze modes can be activated depending on the weather conditions.

The system monitors the ambient temperature and the water temperature to activate the anti-freeze program if necessary.

First antifreeze system:

When the outside temperature is lower than 2 ° C, the system starts the circulation pump for 5 minutes every 40 minutes. when the water outlet temperature is less than 4 ° C, the circulation pump starts automatically.

Second antifreeze system:

If the outdoor temperature is below 2 ° C and the water temperature is below 4 ° C, the heat pump switches to heating mode until the water temperature is above 15 ° C. or the ambient temperature is above 8 ° C.

When the pump is in antifreeze mode, an E04 error is displayed if the water outlet temperature is less than 2 ° C. This code disappears when the outlet water temperature exceeds 4 ° C.

5.5 WiFi Configuration

In the main interface, tap on the WiFi logo.

- «Smart configure»

this mode allows you to intelligently configure the WiFi connection. Once this mode is activated, the “WiFi” logo flashes. Launch your Tuya Smart application on your phone and connect to your heat pump.

- «AP Configure»

This mode creates a WiFi Hotspot. Connect your smartphone to the heat pump HotSpot then launch your Tuya Smart application.

Find more information in the WiFi manual dedicated to the Tuya Smart application at: www.poolex.fr

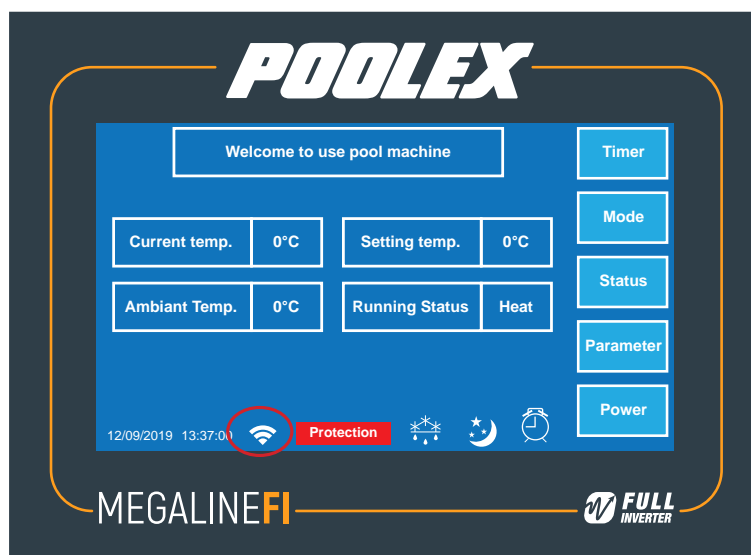

5. Operation

5.5.1. Downloading & Installing the «Smart Life» app

About the Smart Life app:

You'll need to create a «Smart Life» account to control your heat pump remotely.

The «Smart Life» app lets you control your home appliances from anywhere. You can add and control multiple devices at once.

- Also compatible with Amazon Echo and Google Home (depending on the country).
- You can share your devices with other Smart Life accounts.
- Receive real-time operational alerts.
- Create scenarios with several devices, depending on the app's weather data (geolocation required).

For more information, go to the «Help» section of the «Smart Life» app

The «Smart Life» app and services are provided by Hangzhou Tuya Technology. Poolstar, owner and distributor of the Poolex brand, cannot be held responsible for the operation of the «Smart Life» app. Poolstar has no visibility on your «Smart Life» account.

iOS :

Search for «Smart Life» in the App Store to download the app:

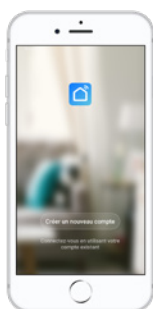

Check the compatibility of your phone and the version of your OS before installing the application

Android :

Search for «Smart Life» on Google Play to download the app :



Check the compatibility of your phone and the version of your OS before installing the application

5. Operation

5.5.2. Setting up the app

WARNING : Before you begin, make sure you have downloaded the «Smart Life» app, connected to your local WiFi network, and that your heat pump is electrically powered and running.

You'll need to create a «Smart Life» account to control your heat pump remotely. If you already have a Smart Life account, please log in and go directly to step 3.

Step 1 : Click on «Create new account» and choose to register by «Email» or «Phone,» where a verification code will be sent to you.

Enter your email address or phone number and click «Send verification code».

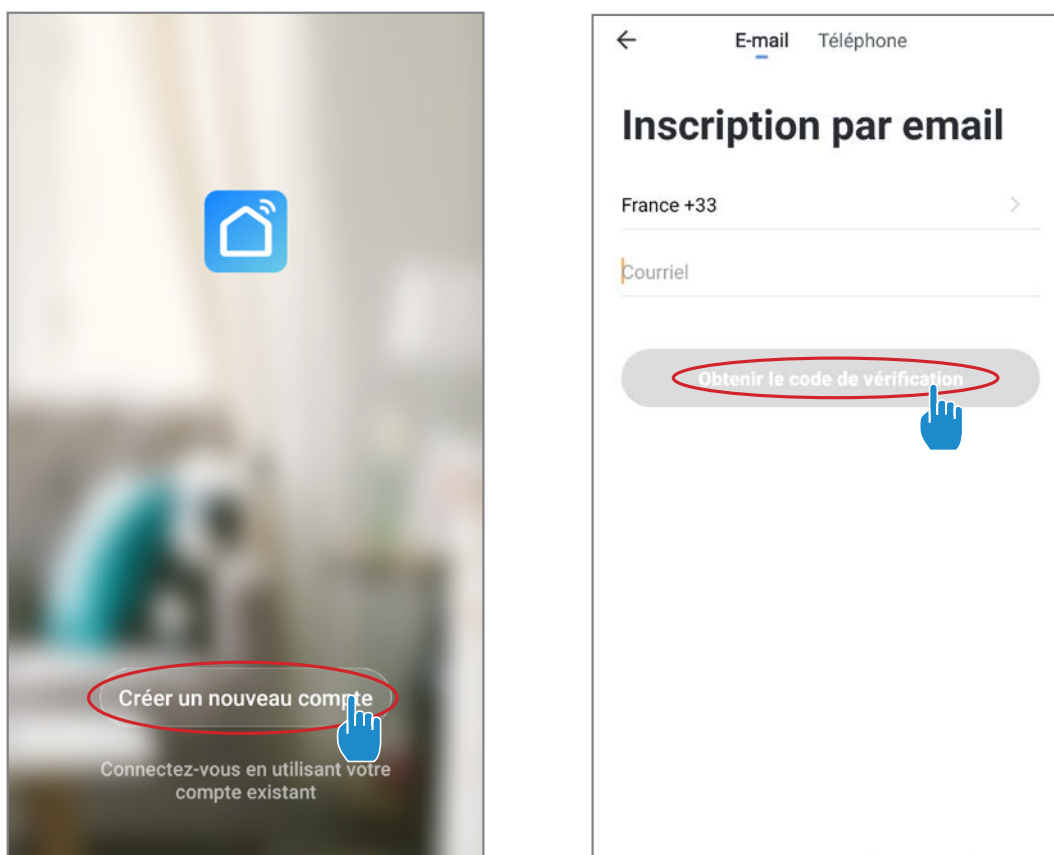

Step 2 : Enter the verification code received by email or phone to validate your account.

Congratulations! You are now part of the «Smart Life» community.

5. Operation

Step 3 (Recommended): Add an object by clicking «...» and then «Add Object.» Enter its name («Pool» for example), then click «Done.»

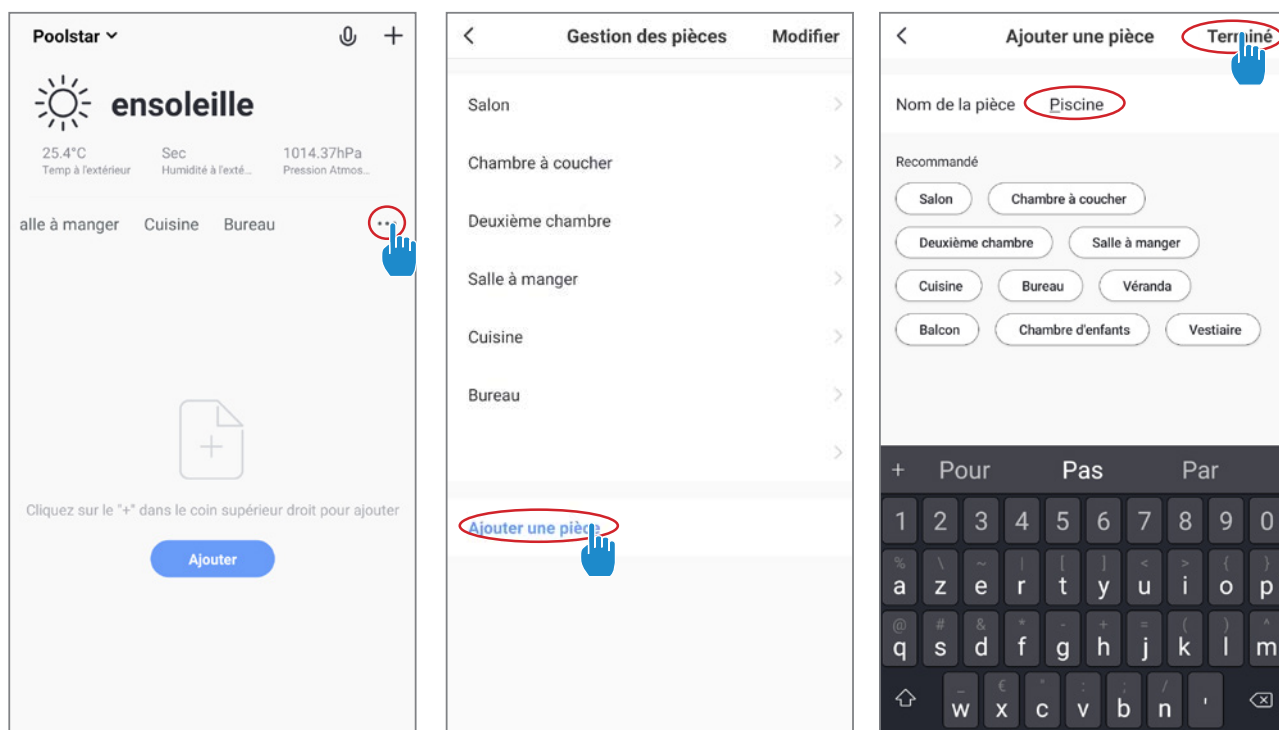

Step 4 : Now add a device to your «Pool»

Click «Add» or «+» and then «Large appliances...» followed by «Water heater.»

At this point, leave your smartphone on the «Add» screen and go to the pairing step for your control box.

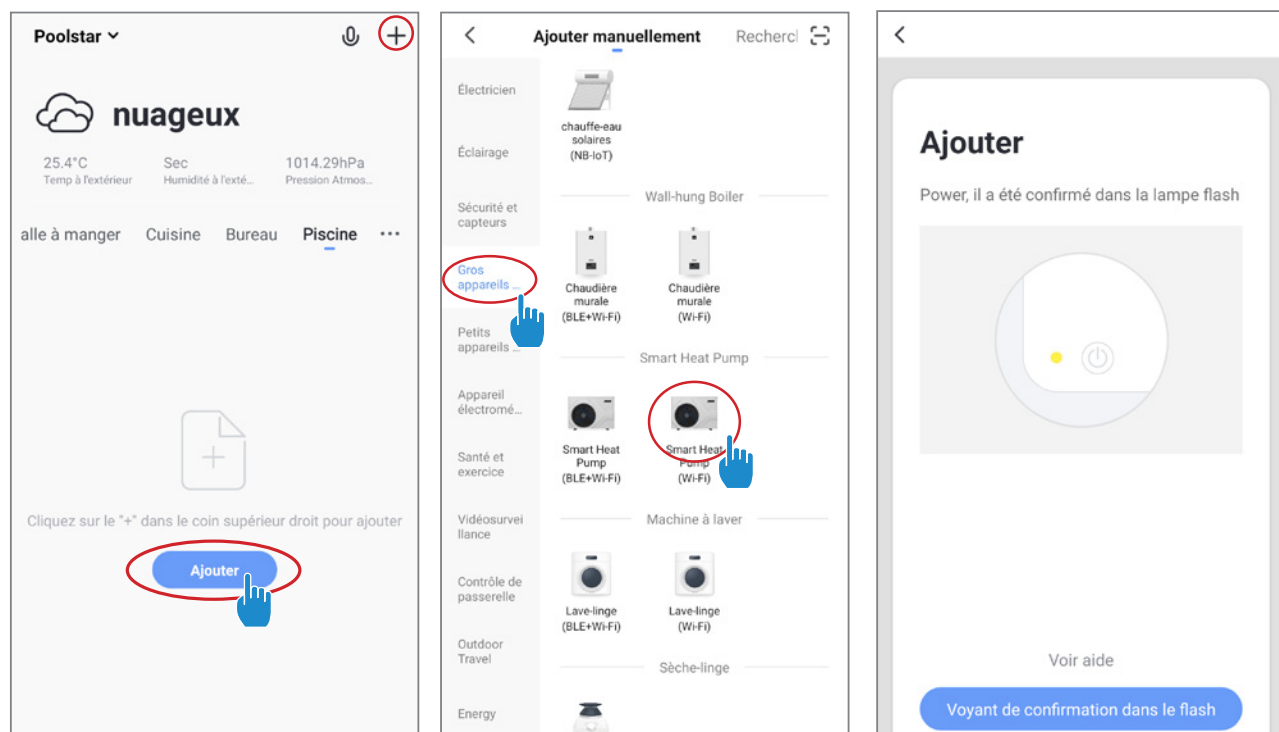

5. Operation

5.5.3. Pairing the heat pump

3.1 EZ Mode

Step 1 : Now start the pairing.

Choose your home WiFi network, enter the WiFi password and press «Confirm».

Step 2 : Activate the pairing mode on your heat pump according to the following procedure:

The procedure depends on the model of your control box:



CAUTION The «Smart Life» application only supports 2.4GHz WiFi networks. If your WiFi network uses the 5GHz frequency, go to the interface of your home WiFi network to create a second 2.4GHz WiFi network (available for most Internet boxes, routers and WiFi access points).



Step 5 : Activate the pairing mode on your heat pump according to the following:

Push 

Note: The blinking will stop when the box is connected to WiFi

Step 6 : Now activate the pairing.

Choose the WiFi network to use, enter its password and click «Confirm.»

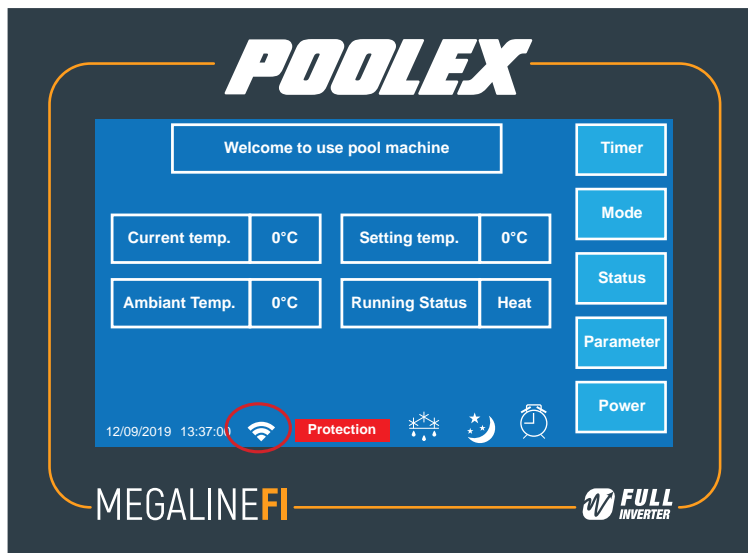

5. Operation

4. Controlling

Interface

- 1 Current pool temperature
- 2 Temperature setpoint
- 3 Current operating mode
- 4 Switch the heat pump on/off
- 5 Change the temperature
- 6 Change the operating mode
- 7 Set the operating range

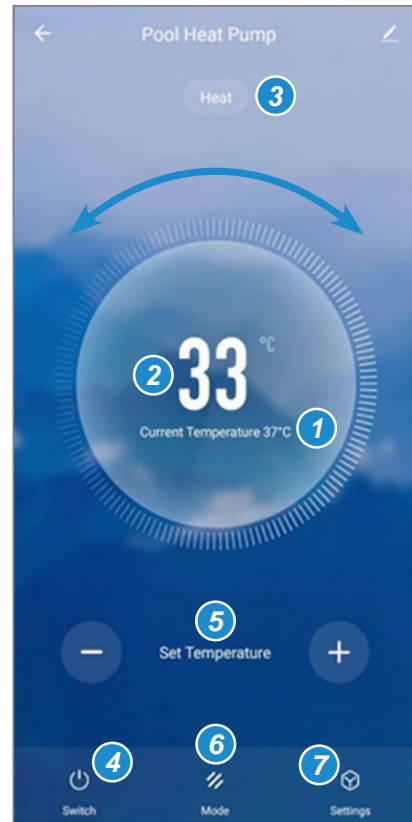

Configure the operating ranges for the heat pump

Step 1 : Create a schedule, choose the time, day(s) of the week(s), and the action (turn on or off) and save.

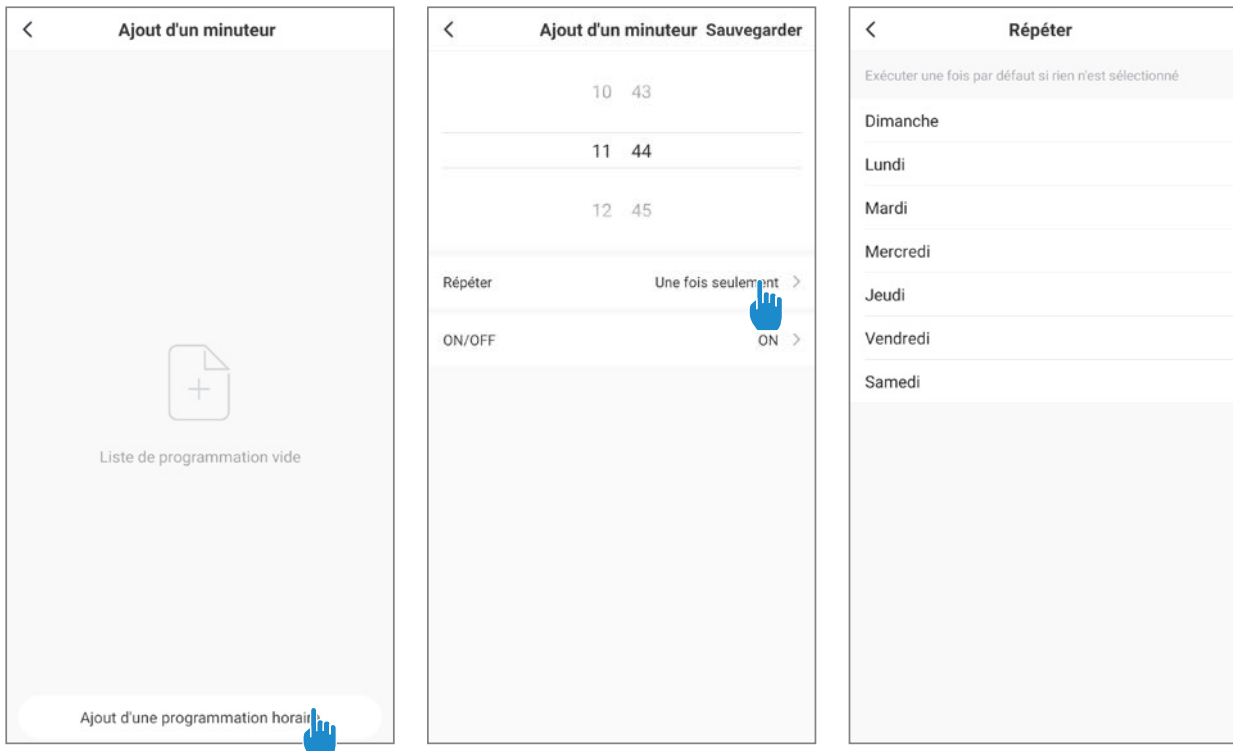

Step 2 : To delete a time slot, press on it and hold.

6. Maintenance and servicing

6.1 Maintenance and servicing



WARNING: Before undertaking maintenance work on the unit, ensure that you have disconnected the electrical power supply.

Cleaning

The heat pump's casing must be cleaned with a damp cloth. The use of detergents or other household products could damage the surface of the casing and affect its properties.

The evaporator at the rear of the heat pump must be carefully cleaned with a vacuum cleaner and soft brush attachment.

Annual maintenance

The following operations must be undertaken by a qualified person at least once a year.

- 6 Carry out safety checks.
- 6 Check the integrity of the electrical wiring.
- 6 Check the earthing connections.
- 6 Monitor the state of the pressure gauge and the presence of refrigerant.

6.2 Winter storage

In the winter months when the ambient temperature is lower than 3°C, a shut-down heat pump must be winterised to avoid any frost damage.

Winterising in 4 steps



Step 1
Disconnect the heat pump from the power supply.

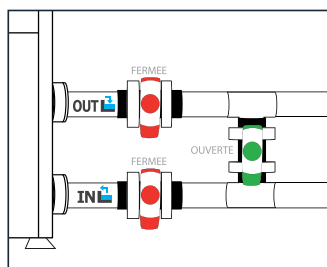

Step 2
Open the By-Pass valve. Close the inlet and outlet valves.

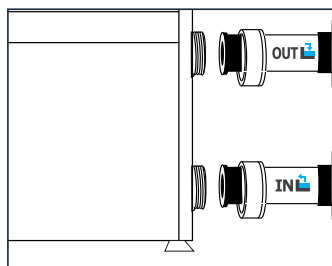

Step 3
Unscrew the water pipes in order to drain any water from the heat pump.

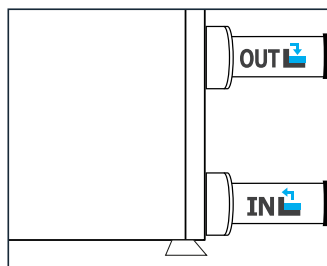

Step 4
Screw back the pipes or block them with rags so as to prevent any foreign bodies from getting into the circuit. Finally, protect the pump with its winter storage cover.



If a circulating pump is servo-controlled by the heat pump, drain this also.

7. Repairs



WARNING: Under normal conditions, a suitable heat pump can heat the water in a swimming pool by 1°C to 2°C per day. It is therefore quite normal to not feel any temperature difference in the system when the heat pump is working. A heated pool must be covered to avoid any loss of heat.

7.1 Breakdowns and faults

In the event of a problem, the heat pump screen displays the “Protection” symbol. Press the symbol to identify the problem.

To view the history of anomalies encountered, press “Status” then Fault Query “

Fault code examples:

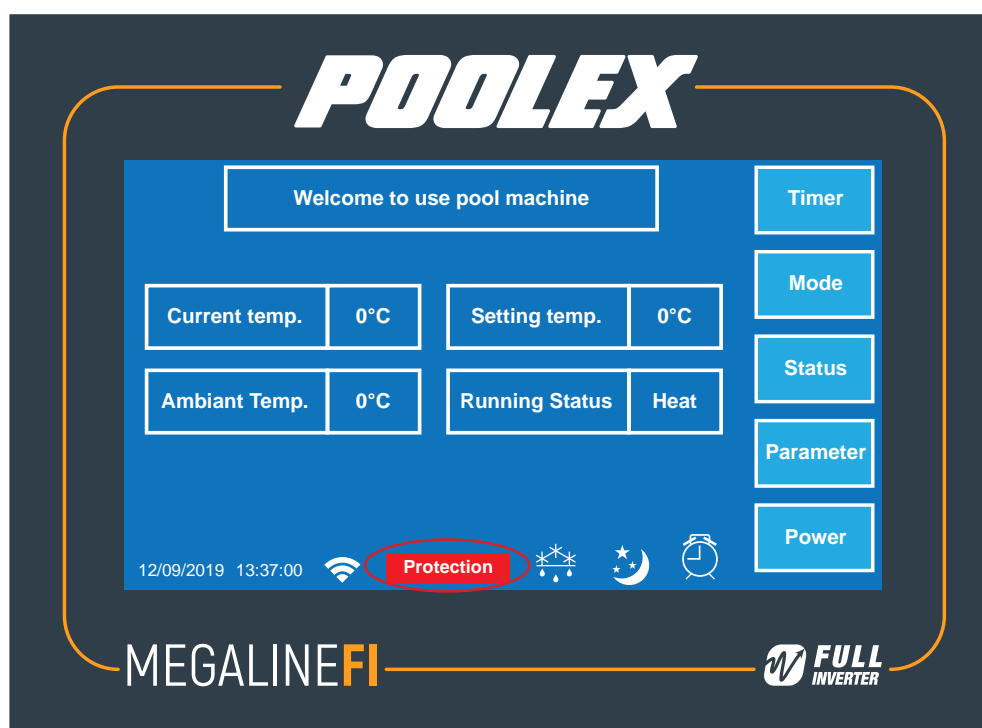

7. Repairs

7.2 List of faults

Erreur		
No Flow	1) The sensor is not properly connected	1) Reconnect the sensor
	2) The sensor is defective	2) Replace the sensor
	3) The electronic card is defective	3) Replace the electronic board
Level 1 anti-freeze protection	The ambient temperature is too low	No action possible
Level 2 anti-freeze protection	The ambient temperature is too low	No action possible
High pressure 1 protection High pressure 2 protection	1) Insufficient water flow	1) Check the operation of the water pump and the opening of the inlet / outlet valves of the By Pass
	2) Defective 4-way valve or refrigerant overload	2) Readjust the refrigerant charge
	3) Setting the water temperature too high	3) Set the target temperature to 5 ° C
	4) Pressure switch disconnected or defective	above the current temperature then proceed in 5 ° steps
Low pressure 1 protection Low pressure 2 protection	1) Not enough refrigerant	3) Reconnect or replace the pressure switch
	2) 4-way valve defective	4) Replace the electronic board
	3) Pressure switch disconnected or defective	
	4) Defective electronic board	
Connection failure between control main Program board and controller	1) Bad connection between the control box and the electronic board	1) Check the connection cables between the remote control and the electronic board
	2) Defective wired remote control	2) Replace the remote control
	3) Defective electronic board	3) Replace the electronic card
Exhaust temperature 1 over Exhaust temperature 2 over	The heat pump does not work	Check that the filtration pump is working and that the water flow is sufficient (bypass adjustment)
Water inlet sensor failure	1) The sensor is not properly connected	1) Reconnect the sensor
	2) The sensor is defective	2) Replace the sensor
	3) The electronic card is defective	3) Replace the electronic board
Outside coil sensor 1 failure	1) The sensor is not properly connected	1) Reconnect the sensor
Outside coil sensor 2 failure	2) The sensor is defective	2) Replace the sensor
Exhaust sensor 1 failure	3) The electronic card is defective	3) Replace the electronic card
Exhaust sensor 2 failure		
Ambient temperature sensor failure		
Water outlet sensor failure		
Suction pipe sensor 1 failure		
Suction pipe sensor 2 failure	1) The sensor is not properly connected	1) Reconnect the sensor
	2) The sensor is defective	2) Replace the sensor
	3) The electronic card is defective	3) Replace the electronic card
Outside coil temperature 1 over in Cooling Mode Outside coil temperature 2 over in Cooling Mode	The heat pump does not work	Check that the filtration pump is working and that the sensor is correctly connected
Inside coil sensor 1 failure Inside coil sensor 2 failure	1) The sensor is not properly connected	1) Reconnect the sensor
	2) The sensor is defective	2) Replace the sensor
	3) The electronic card is defective	3) Replace the electronic board
Water outlet temperature lower in Cooling Mode Water outlet temperature over in Heat Mode	The heat pump does not work	Check that the filtration pump is working and that the water flow is sufficient (bypass adjustment)
Fan 1 fault	Bad connection	Reconnect the fan
Fan 2 fault	The fan motor is defective	Replace motor
EC Fan 1 fault		

7. Repairs

Connection failure between driver 1 and main Program board	Module disconnected or defective	Reconnect or replace the Module
Connection failure between driver 2 and main Program board	Defective module	Replace the module
Failure of frequency conversion module 1	Module disconnected or defective	Reconnect or replace the Module
Failure of frequency conversion module 2	Defective module	Replace the module

8. Recycling

8.1 Recycling the heat pump

Your heat pump has reached the end of its life and you wish to dispose of it or to replace it. Do not throw it in the rubbish bin.

A heat pump must be disposed of separately with a view to its reuse, recycling or upgrading. It contains substances that are potentially hazardous to the environment but which will be eliminated or neutralised by recycling.

YOU HAVE THREE SOLUTIONS:

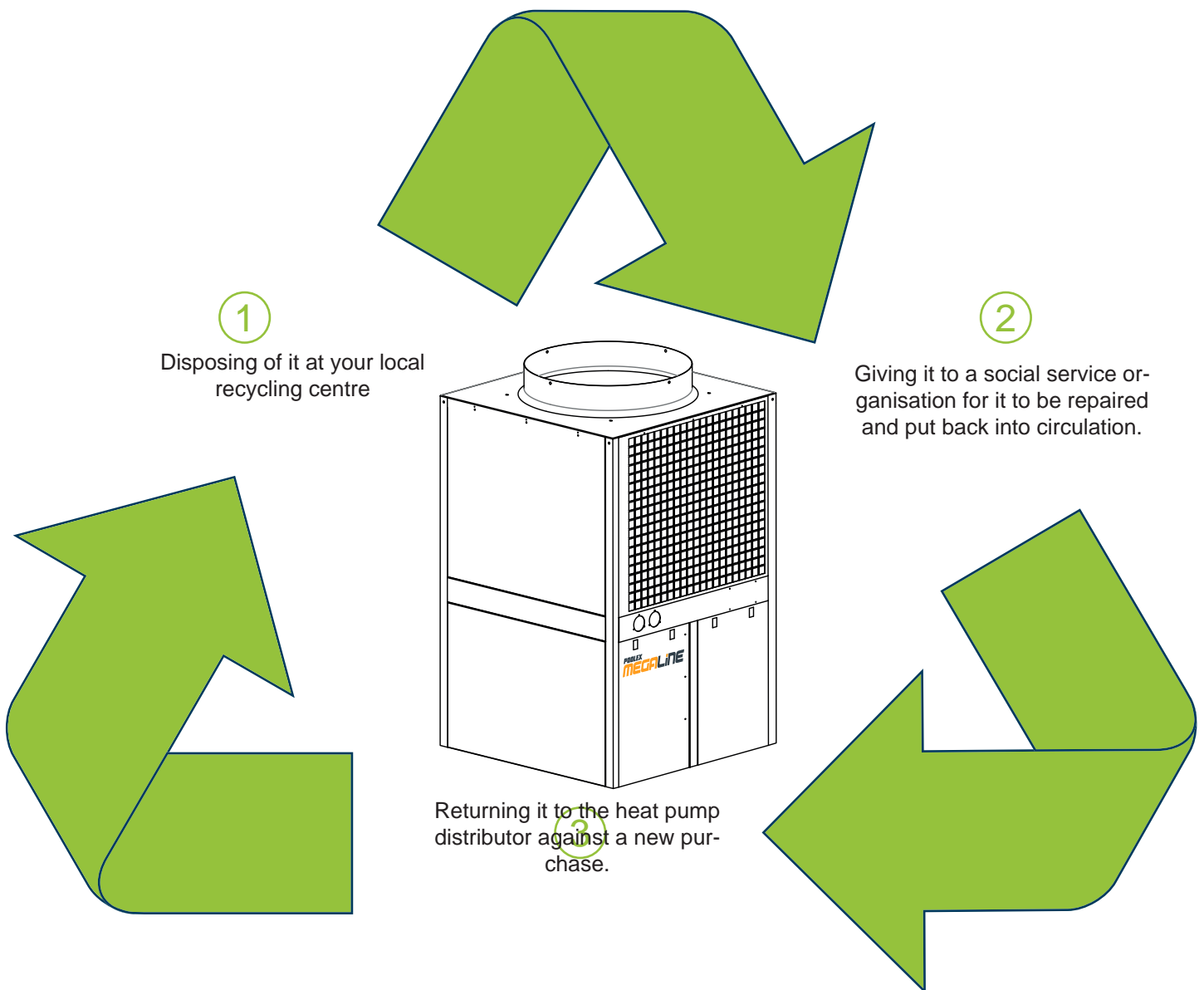

9. Warranty

9.1 General warranty conditions

The Poolstar Company guarantees the original owner against defective materials and faults in the manufacture of the Poolex Jetline Premium Inverter heat pump for a period of three (3) years.

The compressor is guaranteed for a period of seven (7) years.

The titanium tube heat exchanger is guaranteed for a period of fifteen (15) years against chemical corrosion, except for frost damage.

The condenser's other components are guaranteed for three (3) years.

The warranty becomes effective on the date of the first invoice.

The warranty does not apply in the following cases:

- Malfunction or damage arising from an installation, usage or repair that is not in compliance with the safety instructions.
- Malfunction or damage arising from a chemical agent that is unsuitable for the pool.
- Malfunction or damage arising from conditions that are unsuitable for the equipment's purposes of use.
- Damage arising from negligence, accident or force majeure.
- Malfunction or damage arising from the use of unauthorised accessories.

Repairs undertaken during the warranty period must be approved prior to being carried out by an authorised technician. The warranty shall be null and void if the repair to the equipment is carried out by a person who is not authorised by the Poolstar company.

The guaranteed parts shall be replaced or repaired at Poolstar's discretion. Defective parts must be returned to our workshops to be covered during the warranty period. The warranty does not cover labour costs or unauthorised replacements. The return of the defective part is not covered by the warranty.

Dear Sir/Madam,

Please spend a few minutes filling in the warranty registration card that you will find on our website:

<http://support.poolex.fr/>

We thank you for your trust in our products.
Enjoy your swimming!

Your details may be treated in accordance with the Data Protection Act of 6 January 1978 and will not be divulged to any third party.

WARNING:

The contractual warranty cannot be validated with the installer or Poolstar unless your product has been registered on our website.

10. Appendices

10.1 Schémas de câblage

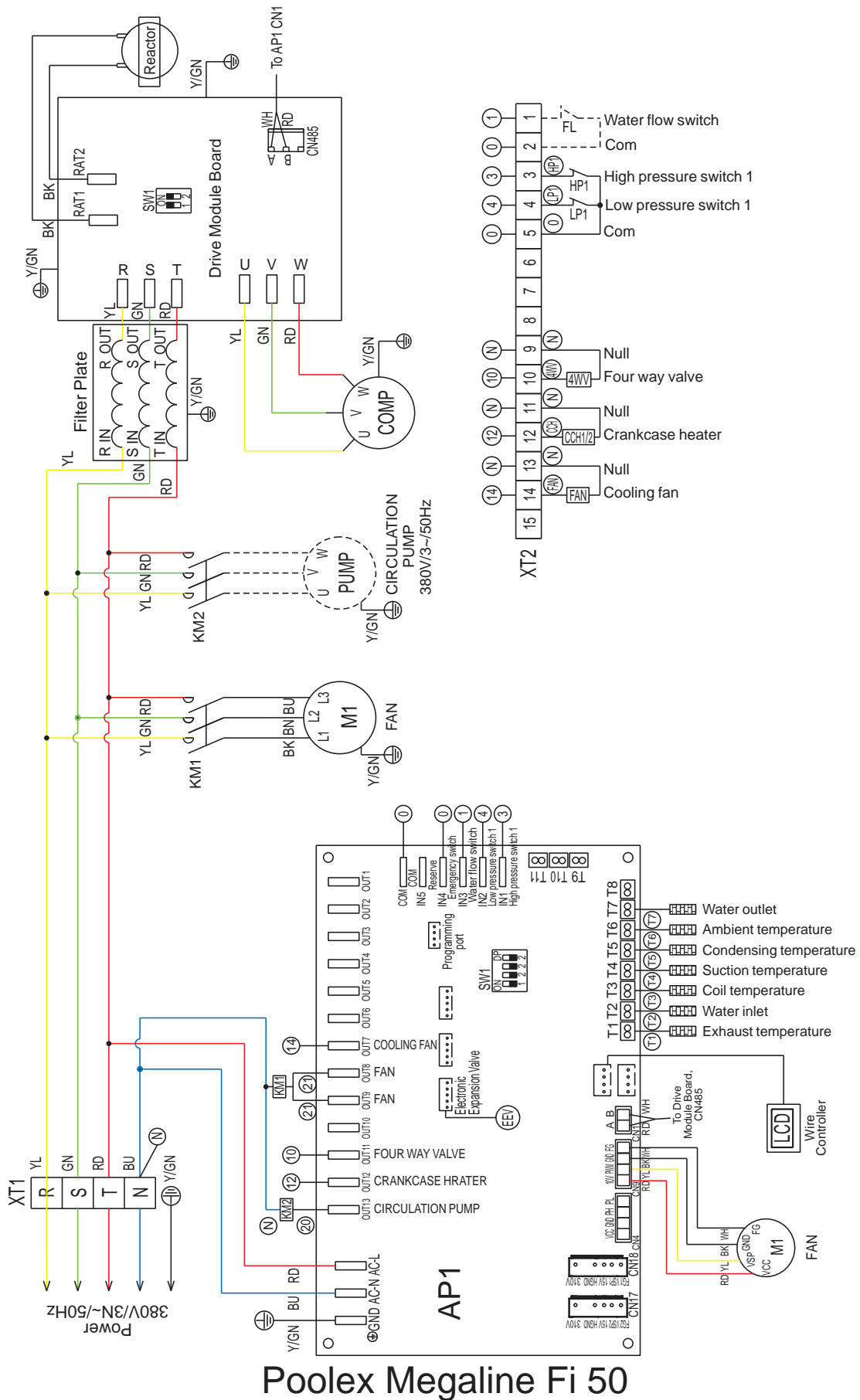

10. Appendices

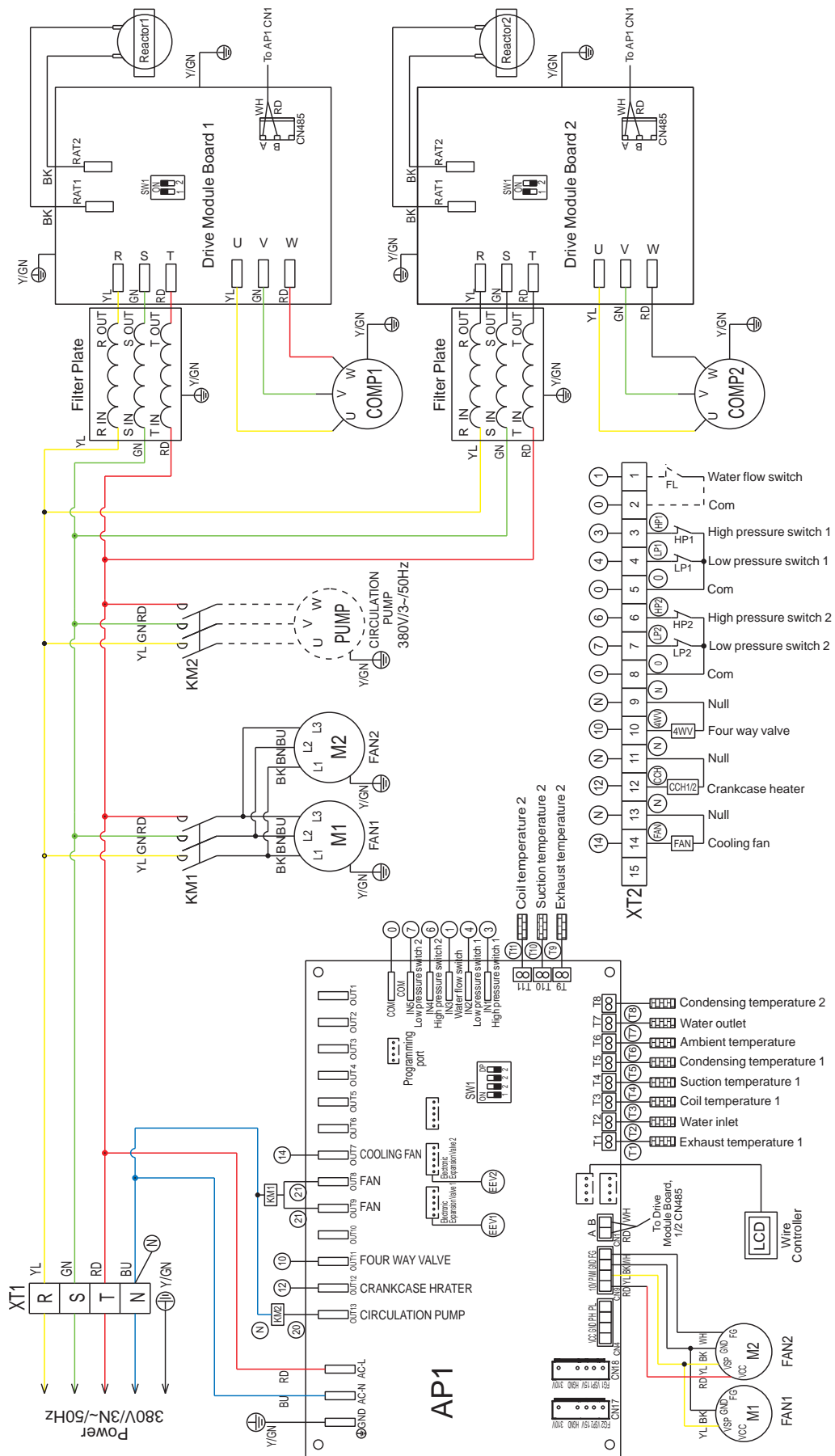

Poolex Megaline Fi 75

10. Appendices

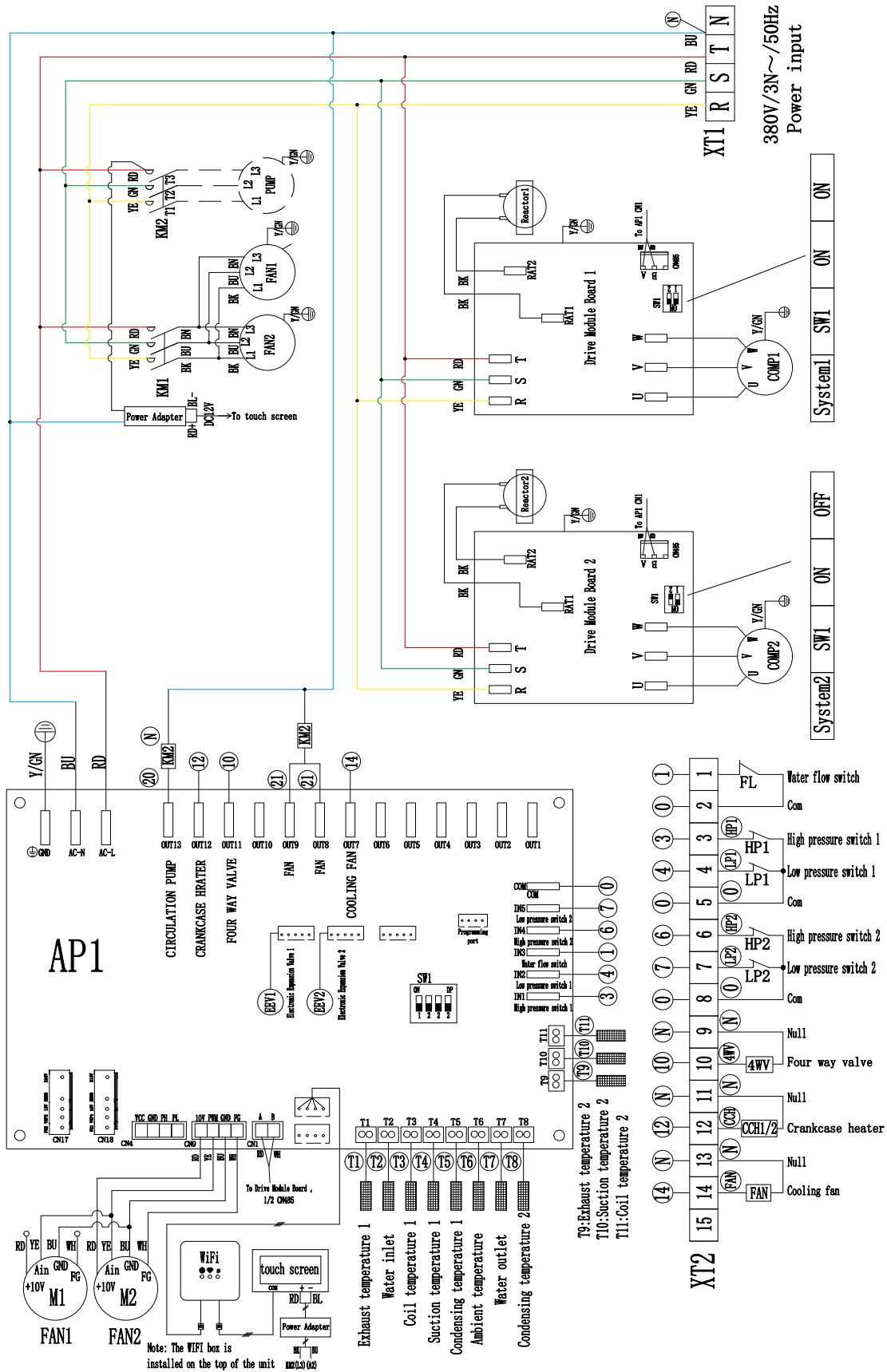

Poolex Megaline Fi 100

POOLEX

MEGALINE FI

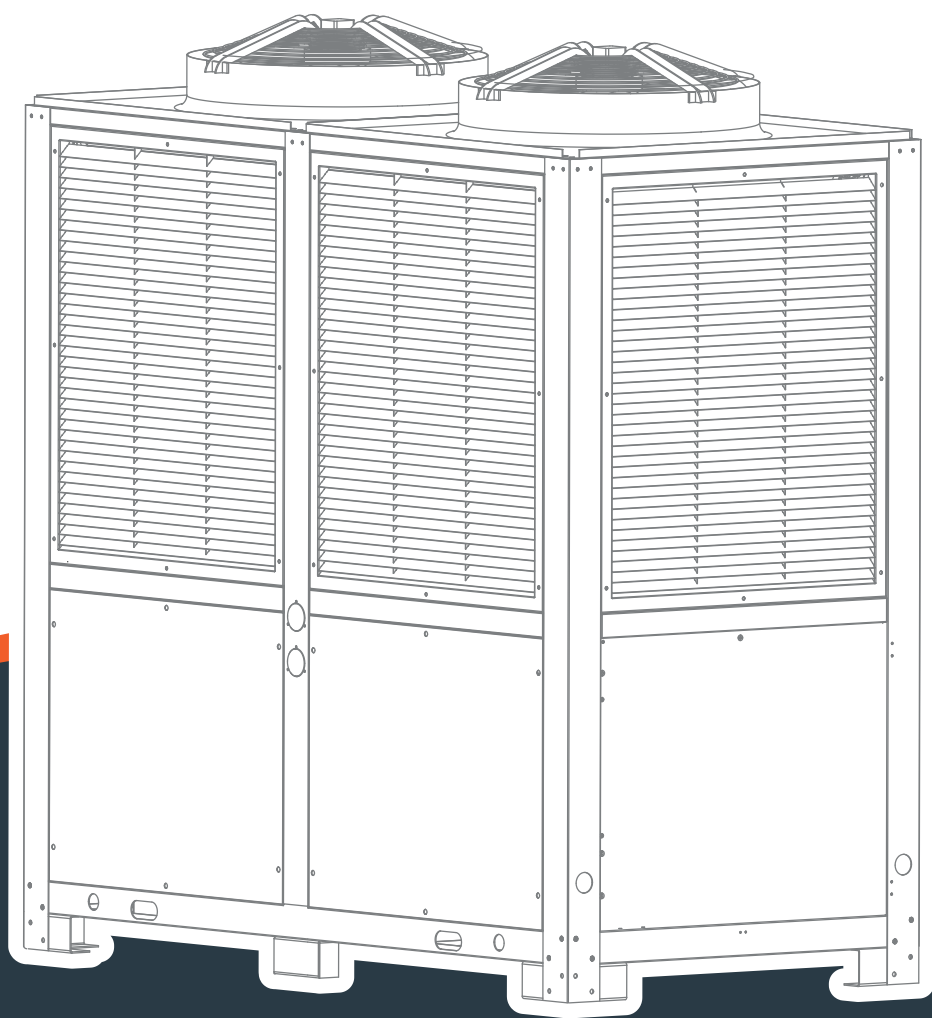

RoHS CE

TECHNICAL ASSISTANCE

www.poolex.fr