

AES DIR Electromechanical Pump Control Panel Wiring Diagrams

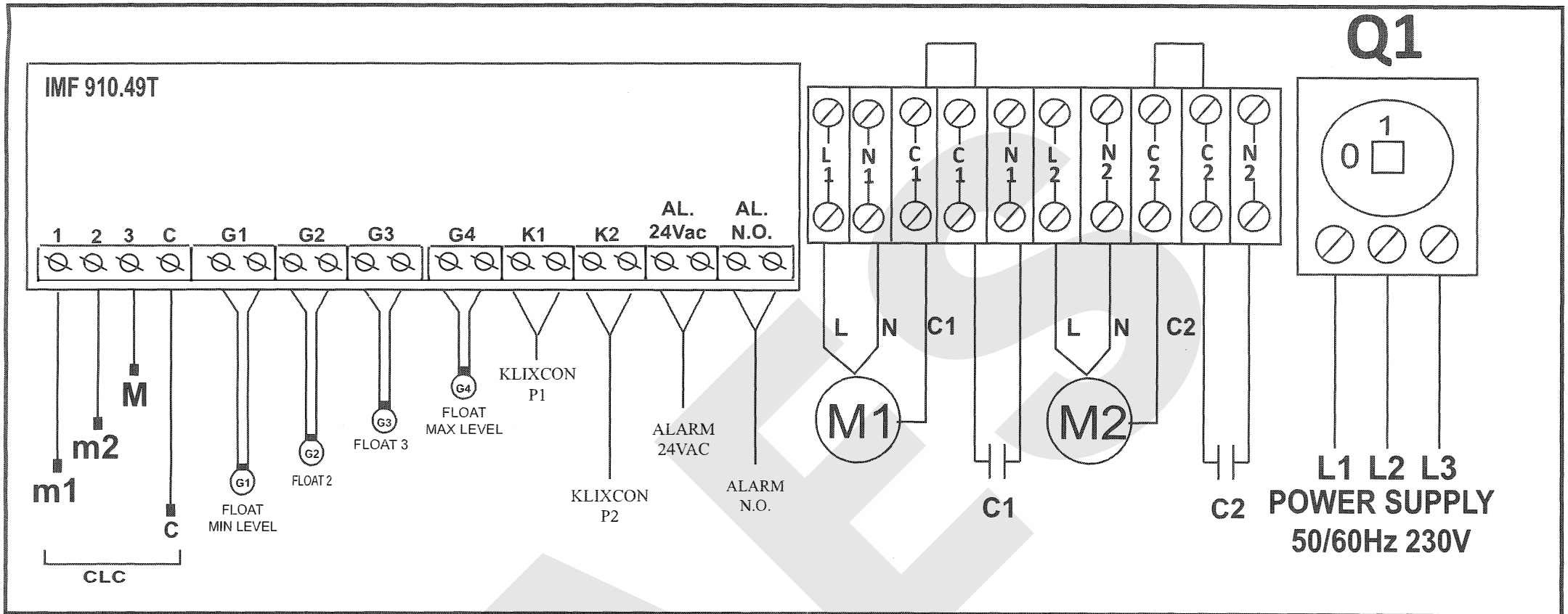

BASE COMPONENTS

Q1 : GENERAL SWITCH WITH DOOR-LOCK
 F1 : PROTECTION FUSE M1
 F2 : PROTECTION FUSE M2
 F3 : TR1 PROTECTION FUSE
 F4 : AUXILIARY PROTECTION FUSE
 KM1 : LINE CONTACTOR MOTOR 1
 KM2 : LINE CONTACTOR MOTOR 2
 FR1 : THERMAL RELAY KM1
 FR2 : THERMAL RELAY KM2
 TR1 : TRANSFORMER 0-230V/0-24V
IMF 910.48M : INTEGRATED MODULE
 SP1 : INDICATOR LIGHT POWER
 SP2 : INDICATOR LIGHT MOTORE 1 ON
 SP3 : INDICATOR LIGHT MOTORE 2 ON

SP4 : INDICATOR LIGHT ALARM MOTORE 1
 SP5 : INDICATOR LIGHT ALARM MOTORE 2
 SP6 : INDICATOR LIGHT ALARM (BUZZER)
 DEV1 : AUT/0/MAN SELECTOR MOTORE 1
 DEV2 : AUT/0/MAN SELECTOR MOTORE 2
 P1 : MUTE BUTTON
 RL1 : RELE MUTE BUTTON

AES AUTOMATED ENVIRONMENTAL SYSTEMS LTD
 1 WIMBLEDON AVENUE, BRANDON, SUFFOLK, IP27
 TEL: 0845 803 5582
 Automated Environmental Systems www.automatedenvironmentalsystems.co.uk

MOD: DIR 2 M1.5

RATED VOLT: 230 / 1PH 50-60HZ

POWER: (2x) 1.5 HP

Date: 06/2021

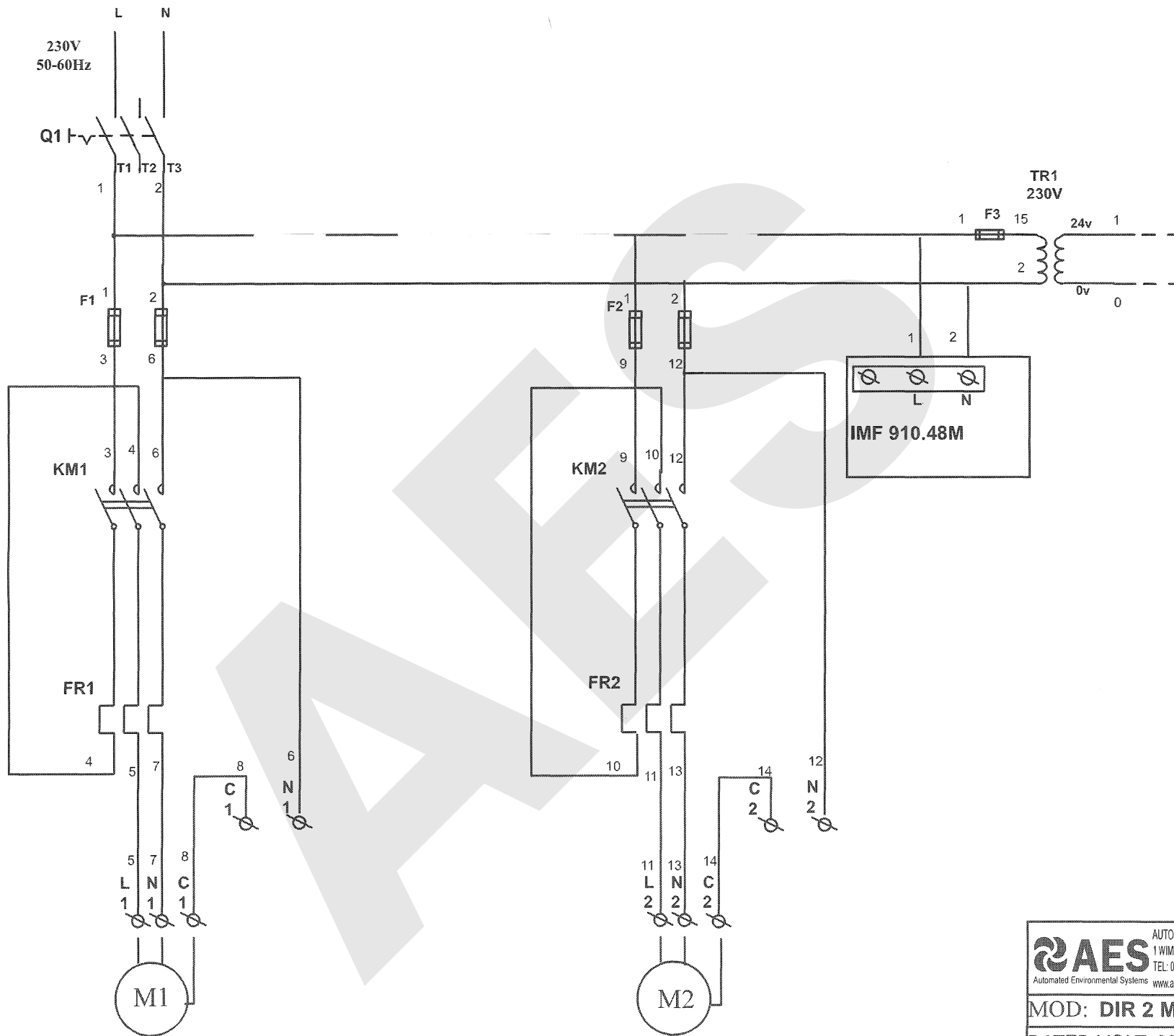

AES AUTOMATED ENVIRONMENTAL SYSTEMS LTD
 1 WIMBLEDON AVENUE, BRANDON, SUFFOLK, IP27
 TEL: 0845803 5582
 Automated Environmental Systems www.automatedenvironmentalsystems.co.uk

MOD: DIR 2 M1.5

RATED VOLT: 230 / 1PH 50-60HZ

POWER: (2x) 1.5 HP

Date: 06/0021

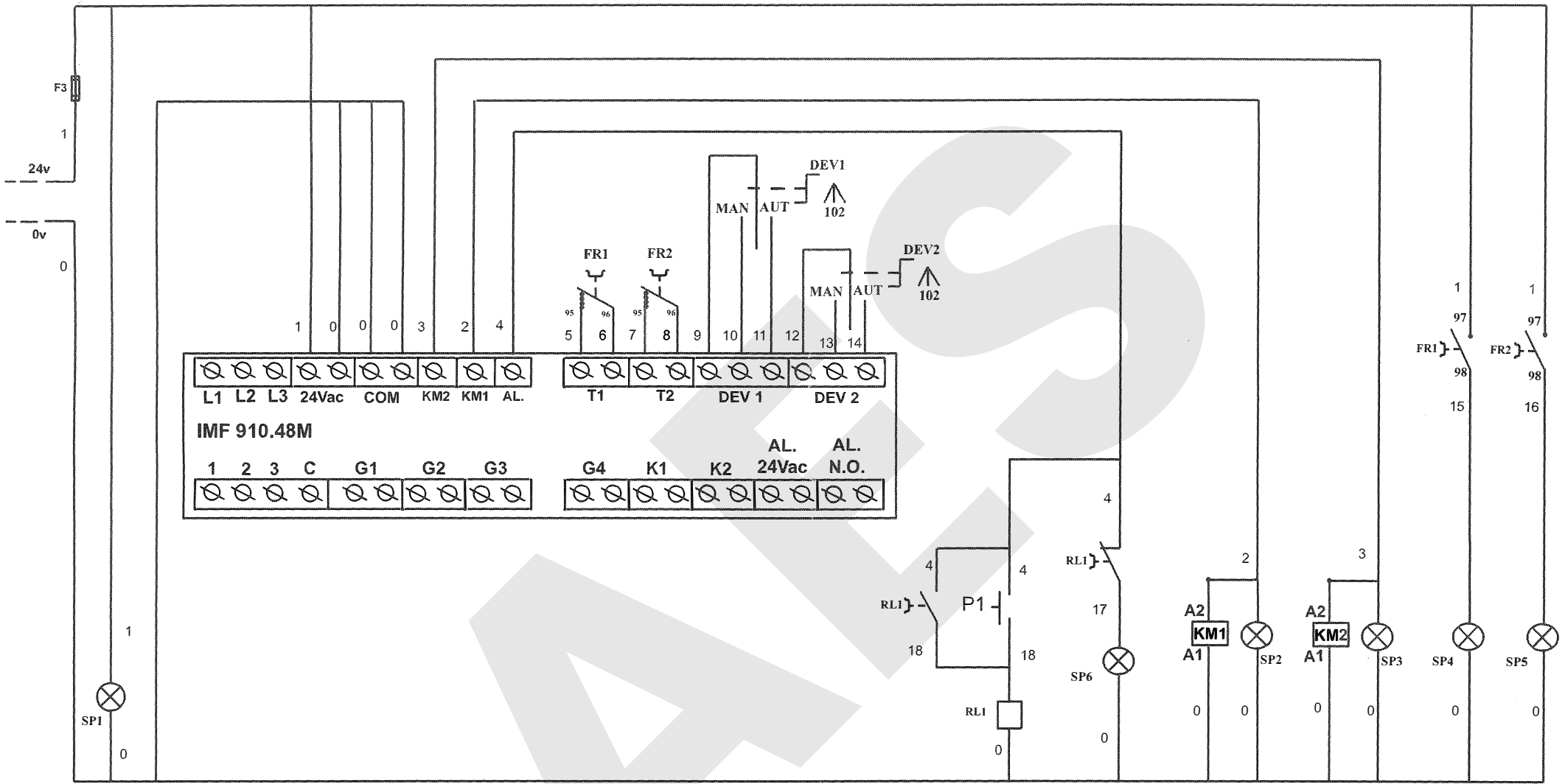

MAIN

MOTORE 1
ON

MOTORE 2
ON



Sales and service 01842 819130

AES AUTOMATED ENVIRONMENTAL SYSTEMS LTD
 1 WIMBLEDON AVENUE, BRANDON, SUFFOLK, IP27 0J
 TEL: 0845 803 5582
 Automated Environmental Systems www.automatedenvironmentalsystems.co.uk

MOD: DIR 2 M1.5
 RATED VOLT: 230 / 1PH 50-60HZ
 POWER: (2x) 1.5 HP