



Description

The Informa is a Speech Dialler for use with intruder alarm systems. When the control panel recognises an alarm it triggers the Informa.

The Informa uses a telephone line to dial a pre-programmed telephone number. It then replays a previously recorded message, thereby alerting the recipient of the call to the alarm and potential intrusion.

Features

- ❖ One location message of 11 seconds, and three alarm messages of three seconds each.
- ❖ Recorded messages stored in non-volatile memory.
- ❖ All telephone numbers stored in non-volatile memory.
- ❖ Unique, easy to use, 'Follow Me' telephone number.
- ❖ Three trigger inputs, programmable as active high or low, linked to phone numbers or alarm messages.
- ❖ Last event memory.
- ❖ Comprehensive test facilities.
- ❖ Supplied with telephone lead for easy installation.

Table of Contents

Features	1	Technical Specifications	14
Description	1	Using the Informa as a Standalone Unit	14
Messages	2	Quick Reference	17
Telephone Numbers	3		
The Follow Me Function	3		
Operating Setup	3		
Input Association	3		
Sequential Dialling	3		
Non-Sequential Dialling	4		
Message Acknowledgement	4		
Mounting	5		
Connecting the Power Supply	6		
Connecting to Control Panels	6		
Communicating Panels	6		
Connecting to the Accenta Gen 4	6		
Connecting for the Follow Me Function	6		
Connecting to ‘Bells Only’ panels	6		
Connecting to the Telephone Network	7		
Using the Supplied Telephone Lead	7		
Connecting Directly to a Master Jack	7		
Parallel Connection	8		
PABX Connection	8		
Payphones	8		
Engineer Programming	9		
Displaying the Informa Status [0]	9		
The Informa Tones	9		
Volume Control [1]	9		
Message Timeout [2]	10		
Setting up the Inputs [3]	10		
Setting Trigger Levels [4]	10		
Viewing the Last Event [5]	10		
Enabling the Follow Me Function [6]	11		
Changing the Customer Code [8]	11		
Changing the Engineer Code [9]	11		
Recording Messages [REC]	11		
Playback of Messages [PLAY]	12		
Performing a Test Call [TEST]	12		
Programming Telephone Numbers [TEL]	12		
Quitting Engineer Mode [QUIT]	12		
NVM Reset	13		
Factory settings (defaults)	13		
Applications	13		
Ringer Equivalence Number	13		

Messages

The Informa can record four spoken messages in its non-volatile memory (NVM). Message number 1 (the location message) may be up to 11 seconds long, messages 2, 3 and 4 may be up to three seconds long, and are used as alarm messages.

When the Informa makes a call it always plays the location message first.

- ❖ Typically the location message is used to identify the location of the Informa, e.g. “This is the Alarm Panel at the house of Fred Smith in Wigan”.
- ❖ The other three messages – the alarm messages – are normally used to indicate the type of alarm or problem that has occurred, e.g. ‘Intruder’, ‘Fire’ and ‘Personal Attack’.

Telephone Numbers

The Informa can be programmed to accept up to four telephone numbers. Three of these numbers are permanently stored via the Engineer program in the NVM. The fourth phone number can be programmed by the customer and is called ‘Follow Me’.

The Follow Me Function

The Follow Me feature is designed to be used by customers who move from one location to another, or go away on holiday.

The customer can re-program the Follow Me number each time that he leaves the premises and sets the alarm system. In this case, the Follow Me number is the first number dialled by the Informa if there is an alarm.

The Follow Me telephone number is entered into the Informa (if required), before the system is set. When the system is unset the Follow Me telephone number will be deleted from the Informa.

For complete instructions, see page 11 of the *Programming* section: *Enabling the Follow Me Function*.

Operating Setup

The Informa has three inputs, labelled IP1, IP2 and IP3 on the PCB, which should be connected to the control panel communicator outputs. Any of these can be used to trigger the Informa, causing it to communicate its message in the event of an alarm.

The Informa can be programmed to operate in one of two ways:

- ❖ It can communicate an alarm message to a series of numbers, in the case where the first number is not acknowledged (sequential dialling).
- ❖ It can communicate an alarm message to a single number, where the number called depends upon the type of alarm that has occurred (non-sequential dialling).

For a complete explanation, see *Input Association*.

For instructions on how to programme the inputs, see page 10, *Setting Up the Inputs*.

Input Association

1. Sequential dialling

This function gives priority to a person, and can be used to call the person responsible for the premises, plus anyone they have designated to take the call.

If the Follow Me number is valid it will dial this first, otherwise it will dial the first configured telephone number. It will play the location message, followed by the alarm message associated with the triggered input, where IP1 plays message 2, IP2 plays message 3, etc.

An example of a message could be:

Location message: “This is the alarm system at Mr and Mrs Smith's house, 1 The Avenue, Smith Town.”

Alarm message: “The intruder alarm has been activated.”

If two inputs are triggered at the same time the Informa will play both alarm messages. If the Informa is not acknowledged it will attempt to communicate with the second telephone number, then the third, see *Message Acknowledgement*, on page 4.

2. Non-sequential dialling

This function is based on the type of alarm.

If IP1 has been triggered, the Informa will dial the first telephone number and play the location message, followed by message 2.

If IP2 has been triggered, the Informa will dial the second telephone number and play the location message, followed by message 3.

If IP3 has been triggered, the Informa will dial the third telephone number and play the location message, followed by message 4.

If there is no acknowledgement, the Informa will only attempt seven more times to communicate with the original telephone number.

Message Acknowledgement

The recipient must always acknowledge the call made by the Informa in order to terminate its dialling sequence.

After replaying its two or more messages the Informa will produce a single tone for one second.

The recipient then has an interval of five seconds to press the * (star) key on the telephone.

The Informa will repeat its tone for one second and the user must again press the * key within five seconds.

The Informa will then sound two short beeps to indicate that it has received the acknowledgement and then hang up. Note that it is **only** possible to acknowledge the call with a tone-dialling telephone.

Installation

Mounting

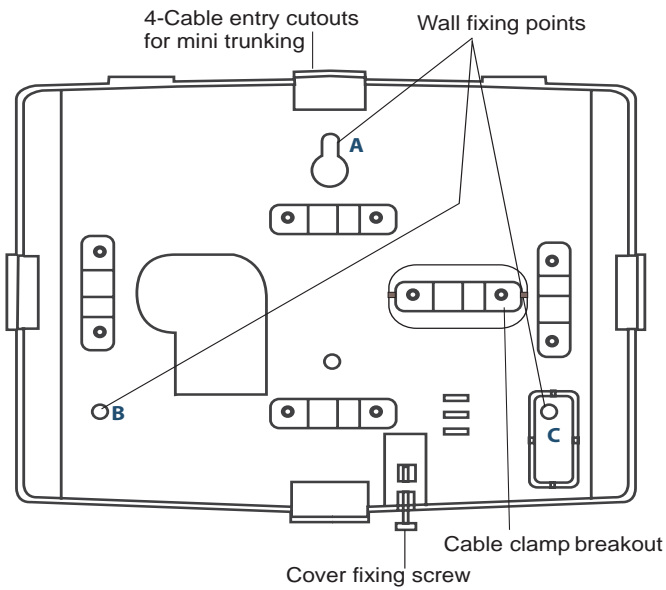

Before installing the Informa, power down the control panel to which it is to be connected, by removing both mains and battery power.

Break out the cable clamp strap from the back plate. Fasten the Informa's backplate securely to the required position on a wall, using fixing points A, B and C, and breaking out whichever cable entry is to be used.

NB: Ensure that wall fixing point C is fixed securely, as this ensures tamper activation if the unit is forcibly removed from the wall.

The cutouts are designed to take mini-trunking directly. Run the cable from the alarm panel to the Informa back plate as required.

Run the cable from the position of the telephone master socket to the Informa back plate. Secure both of these cables to the nearest cable clamp using the cable clamp strap removed earlier. Use the two small self-tapping screws to fasten the clamp strap across the two cables.

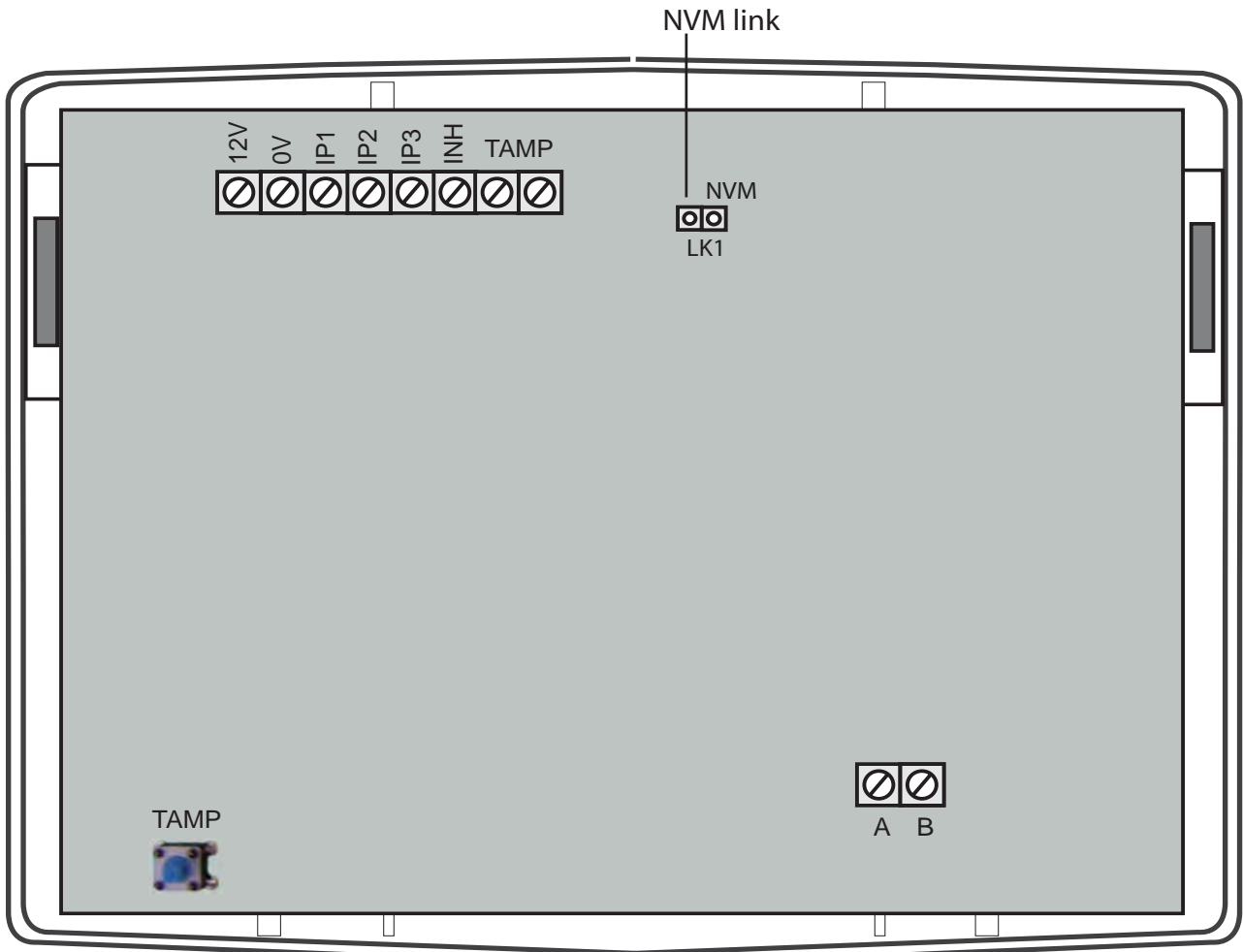

Connecting the Power Supply

The Informa must be connected to a +12V power supply which is fused at 2 Amps or less. Standard alarm cable – 7/0.2mm multicore or equivalent – should be used.

Connect the alarm cable wiring – starting with the +12V and 0V connections from the alarm panel – and wire them into the +12V and 0V terminals of the Informa.

If the control panel is not being used as the power supply for Informa, then a common 0V connection between the control panel and Informa must be made.

Now wire as many trigger channels from the alarm panel to the speech dialler as required.

Connecting to Control Panels

Tamper connections are provided for connection to the host control panel, if required

Connecting to Communicating Panels

Most communicating control panels use a +ve (positive) to trigger the communicator outputs. If the control panel used has a –ve communicator output, Informa inputs must be programmed as Active High (+ve trigger), see page 10, *Setting Trigger Levels*.

The Accenta Gen 4 has a dedicated communicator or programmable communicator outputs. This will allow a location message followed by one of three alarm messages to be sent by the Informa.

Connecting to the Accenta Gen 4

Three-channel (three-message) operation is possible with an Accenta Gen 4. Connect the Informa to the panel.

Program all Informa inputs as Active Low (this is the default).

To enable the use of the Follow Me function, connect the SET+ of the panel to the INH input on the Informa. This connection is unnecessary if Follow Me is not used.

Connecting for the Follow Me Function

The INH input is used with the ‘Follow Me’ function, and should be connected to the SET output from the control panel.

When the Follow Me function is enabled, the INH input does not inhibit alarms from IP1 but cancels the Follow Me number whenever the panel is unset.

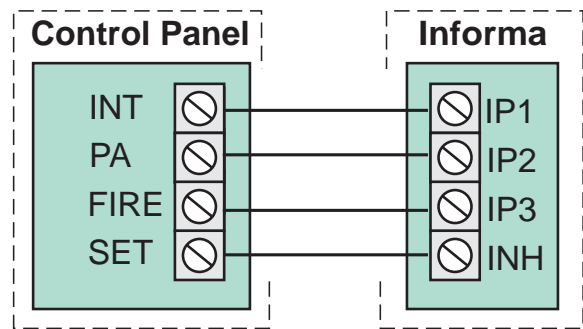

Connecting to a Communicating Control Panel

Connecting to ‘Bells Only’ Panels

Optima Compact Gen 4 control panels are ‘bells only’ panels. With this type of panel, the Informa may be used as a single-channel dialler triggered from the bell output.



Connect trigger IP1 to the bell output of the panel.

The Informa will only be triggered by the bell when the panel has been set.

Most control panels use a –ve (negative) to trigger the bell or sounder. If the control panel used has a –ve bell trigger, the Informa's inputs must be programmed as active low (– trigger). See page 10, *Setting Trigger Levels*. The factory default for these inputs is Active Low.

Connect the Informa as shown below:

- a) SET +: With a SET + connection, a Personal Alarm (PA) will not trigger the Informa unless the panel is set (armed).
- b) Program the Informa’s inputs IP1, IP2 and IP3 as Active Low (the default).

c) Program the INH input as Active High.

Note that if the Follow Me function is enabled in a Bells Only panel, a bell test will cause the dialler to start the call procedure, because the SET+ or SET connection to INH does not prevent dialling when the panel is unset.

Refer to page 3, *The Follow Me Function*.

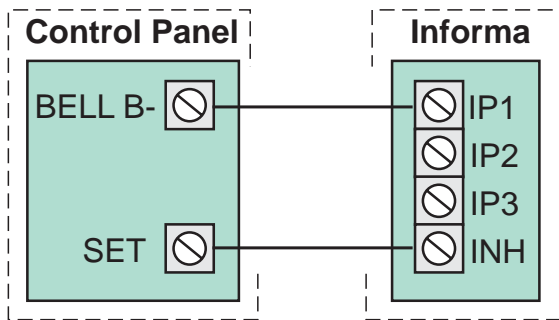

Connecting to a Bells Only Control Panel

i **Note that with a bells only panel, PA only triggers the Informa when the panel is set (armed).**

Connecting to the Telephone Network

Honeywell Security recommends that the Informa be connected to an ex-directory standard PSTN telephone line, and that ideally no other telephone apparatus is connected to the same line.

The Informa may be connected to the telephone network by either of the two methods below:

- a) Using the supplied RJ-11 telecoms lead and suitable adapter to plug into a standard telephone socket.
- b) Using a direct connection to a BT master jack socket using a special telephone cable, see page 7, *Connecting Directly to a Master Jack*.

Using the Supplied Telephone Lead

This two-way lead must be wired to the terminals on the Informa PCB as follows:

Wire Colour	PCB Terminal
White	A
Red	B

Connecting Directly to a Master Jack

Direct connection to a master jack socket should be undertaken by an approved installer, using the connections described below.

The cable used to connect the Informa to the master socket must conform to BT specification CW1308. This has a single-strand conductor of 0.5mm². On no account should any other type of cable be used.

At the master socket identify the terminals A and B. This can be done either by reference to the terminal numbers on the socket, or by the wiring code.

Connect one end of the telephone cable to the Informa terminals labelled A and B. Strip back 5mm

Terminal	Number	Wire Colour
A	5	White with blue rings
B	2	Blue with white rings

of insulation from each of the two conductors, insert the conductors into the terminal block and tighten the screw. The telephone cable should be routed away from all other cables inside the housing.

Connect the other end of the telephone cable to the master socket. It may be necessary to use a special IDT termination tool to do this securely.

Parallel Connection

Although not recommended by Honeywell, the Informa may be connected to the same telephone line as other telephone apparatus.

The Informa can only be connected in parallel with other apparatus, since a series connection facility is not provided.

When connected in this way the installer should check that the combined REN (Ringer Equivalence Number) of all equipment connected in parallel does not exceed the maximum REN permitted by your telephone provider.

PABX Connection

When used on a PABX system the Informa may need access to an 'outside line' before attempting to dial a telephone number. In this case all telephone numbers programmed into the host control panel should be prefixed with the 'outside line' code of the PABX. This is usually 9.

Consult your PABX provider for further details, if required.

Payphones

The Informa is not suitable for connection as an extension to a payphone or 1 + 1 carrier system.

Programming

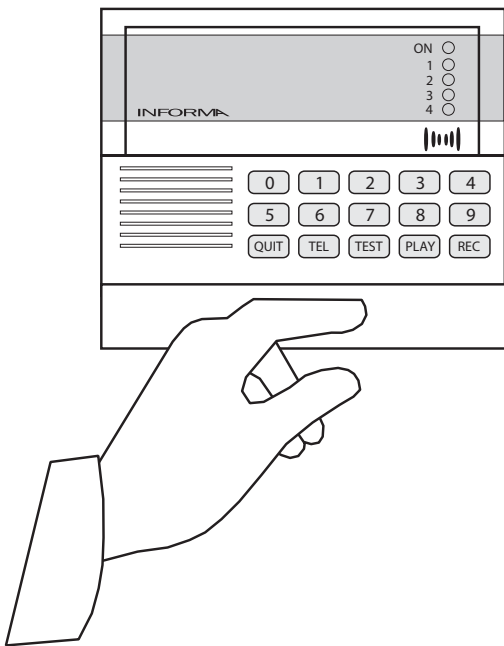

Engineer Programming

The Informa is on standby when only the green Power ‘ON’ LED is lit.

To enter the engineer menu:

- a) Key in the four-digit engineer code.
The factory set engineer code is 9999.
The first three red LEDs light.

Refer also to the *Quick Reference* on page 17 of this guide.

Displaying the Informa Status [0]

You can display the programmed state of each input to the Informa.

- a) Press [0].

The state of the inputs is displayed on the LEDs. LEDs 1 to 3 show the state of inputs IP1 to IP3, LED 4 shows the state of the inhibit input (INH).

An LED is lit when the associated input is active. Note that the inputs can be programmed to be Active High or Low.

- b) Press QUIT to finish.

The Informa Tones

- ❖ To confirm an action, the Informa sounds a fast double-beep.
- ❖ To alert you to an error, the Informa sounds a long two-note signal.

Volume Control [1]

You can alter the volume of the messages when they are played back.

By default the Informa uses Medium 1.

- a) Press 1 to enter volume control mode.
- b) Press:
 - [1] to select Minimum volume
 - [2] to select Medium 1 volume
 - [3] to select Medium 2 volume
 - [4] to select Maximum volume.

When you have chosen the setting, the Informa automatically resets to the top level of the Engineering menu.

Message Timeout [2]

This facility allows the Informa to play the triggered messages more than once to the programmed numbers. It is recommended that this message time is at least twice as long as your recorded messages.

Example: If the location message plus the Alarm message equals 15 seconds, then the Message Timeout setting should be 30 seconds.



Messages will play back as soon as the line is connected, whether the phone is answered or not.

When the Informa makes a call it will always play back its messages for a fixed length of time before it hangs up and tries another number. This fixed length of time is called the 'message timeout' and can be set by the engineer to between 05 and 99 seconds.

- a) Press [2] to change the message timeout.
- b) Type in a two-digit interval from 05 to 99 seconds. For example, if you need 30 seconds, key in 30. When you have chosen the setting, the Informa automatically resets to the top level of the Engineering menu.

Setting Up the Inputs [3]

The Informa can be programmed to associate each of its three inputs either with a message or a telephone number; see page 3, *Input Association*.

- a) Press [3] to change the input association, then:
 - ❖ [1] to set up sequential dialling, which calls up to three numbers in succession.
 - ❖ [2] to set up non-sequential dialling, which calls a particular number, depending upon the type of alarm.

The Informa sounds two fast beeps to confirm the new setup.

When you have programmed the association, the Informa automatically resets to the top level of the Engineering menu.

Setting Trigger Levels [4]

The three inputs (IP1 to IP3), and the inhibit input (INH), can be individually programmed as Active High (+ve trigger) or Active Low (-ve trigger).

An Active High input will trigger the Informa when the voltage present at the input exceeds 3.5V (maximum is 15V).

An Active Low input will trigger the Informa when the voltage is less than 1.0V.

- a) Press [4] to change the trigger levels.

The four LEDs show the trigger level of inputs 1 to 3 and the inhibit input, respectively. A lit LED shows that the input is programmed as active low.

- b) Press keys 1 to 4 to switch the trigger level of the inputs between Active High (+ve trigger) and Active Low (-ve trigger).
- c) Press [PLAY] when finished, or [QUIT] to ignore any changes.

The Informa automatically resets to the top level of the Engineering menu.

Viewing the Last Event [5]

When the Informa is triggered it will log the trigger input (IP1 to IP3) in its event memory.

- a) To view this event, press [5]. One of the LEDs lights, indicating the input that last triggered the Informa.

If the LED lights steadily, it indicates that the call was successfully acknowledged; if the LED flashes, it indicates that the call was not acknowledged.

- b) When you have viewed the event, press [Quit].

The Informa automatically resets to the top level of the Engineering menu.

Enabling the Follow Me Function [6]

The Follow Me function permits the customer to enter a telephone number each time the alarm system is set. The Informa always uses the Follow Me number (if programmed) in preference to the first telephone number.

- a) Press [6] to enable or disable the Follow Me function.
- b) Press [0] to disable the Follow Me function once it is enabled (LED 4 lit) or Press [1] to re-enable the function (LED 1 lit).

The Follow Me function is cancelled each time the panel is Unset.

Changing the Customer Code [8]

Access to the customer menu, for the programming of messages and telephone numbers, is protected by a four-digit code. By default, this is 0123.

This can be changed either by the customer or the engineer, as follows:

- ❖ Press [8], followed by the new four-digit code.

The Informa sounds a fast double-beep to confirm that the new code has been recorded.

If the code is the same as the engineer code, the Informa will not accept it and sounds a long two-note error tone.

After the code is changed, the Informa automatically resets to the top level of the Engineering menu.

Changing the Engineer Code [9]

The engineer code is 9999 by default. You can change this as follows:

- ❖ Press [9] followed by the new four-digit code.

The Informa sounds a short double-beep to confirm that the new code has been recorded.

After the code is changed, the Informa automatically resets to the top level of the Engineering menu.

Recording Messages [REC]

You can program up to four messages.

- ❖ Message 1 is used as the location message.
- ❖ Messages 2, 3 and 4 are used as alarm messages.

To record or re-record a message:

- a) Press [REC] (there is a 1-second pause).
- b) Press the number of the message (1 to 4, where 1 corresponds to the location message).

The Informa pauses for one second then sounds a tone for one second.

- b) Now speak clearly into the microphone, which is positioned just below the LEDs. Message 1 may be up to 11 seconds long; the three alarm messages are 3 seconds long.

Example

- ❖ A location message can be: Message 1- "This is the alarm system at Mr & Mrs Smith's house, 1 The Avenue, Smith Town. There is"
- ❖ The alarm message can be:
 - Message 2: "Fire alarm"
 - Message 3: "Personal Attack"
 - Message 4: "Intruder alarm"

The Informa automatically stops recording at the end of the message delay. If the announcement to be recorded in message 1 is much shorter than 11 seconds you can stop the recording at any time by pressing [PLAY].

After the message is recorded there is a short interval, after which the Informa plays back your recorded message.

Playback of Messages [PLAY]

To play any of the messages previously recorded:

- a) Press [PLAY].
- b) Press the number of the message to be played (1 to 4).

After a short interval the Informa will replay the selected message. Message 1 is the location message and Messages 2, 3 and 4 are alarm messages.

Performing a Test Call [TEST]

To test that the telephone numbers have been set up correctly the Informa can perform a test call. During a test call the speaker will be turned on so that you can hear how the call progresses. To generate a test call:

- a) Press [TEST].
- b) Enter the telephone number (1 to 3) to be tested.

The Informa dials the number then plays message 1 followed by message 2.

Listen for the acknowledge signal. If the Informa receives a valid acknowledgement it hangs up the line and lights all four LEDs steadily. If it fails to receive an acknowledgement it repeats its messages for the duration of the message timeout, then hangs up the line and flashes all four LEDs.

- c) Press [TEST] again to end the sequence.
Informa will automatically reset to the top level of the Engineering menu.

Programming Telephone Nos [TEL]

Up to three telephone numbers can be programmed into the Informa.

This does not include your Follow Me telephone number, which is programmed when the system is set.

Note: The Informa cannot contact the emergency services directly. It will not accept any telephone number starting with 999 or 112.

To program any of the three telephone numbers:

- a) Press [TEL].
- b) Select the telephone number (1 to 3) you want to change.
- c) Enter the telephone number. 21 digits are allowed. The number is automatically saved once the 21st digit is entered

If a number of less than 21 digits is required, press Tel to end the entry of the number.

- d) Press [REC] to add a pause of one second if required. Each depression of the [REC] button equals one digit of the 21 digits allowed.

- e) Now press:

[TEL] to accept the telephone number just entered, if less than 21 digits

[QUIT] to reject the number if you made a mistake

[TEST] to accept the number just entered and immediately make a test call to that number.

To delete a telephone number:

- a) Press [TEL].
- b) Select the telephone number to be deleted (1 to 3).
- c) Press [TEL].

Quitting Engineer Mode [QUIT]

Having completed all programming and test calls, you can return the Informa to standby mode:

Press [QUIT] to leave engineer mode.

NVM Reset

The engineer code, and all other programmable parameters, can be reset to their factory defaults by following the sequence below:

- a) Power down the Informa by removing the 12V supply to the Informa.
- b) Slacken the front cover screw and remove the front assembly to expose the PCB.
- c) Short together the 2 pins labelled “NVM” LK 1 (see diagram on page 5) with the blade of a screwdriver, or the supplied shorting link, and at the same time power up the Informa. The NVM will be reset.
- d) Now remove the short from the 2 pins and refit the front cover.

Your Informa will return to the factory setting.

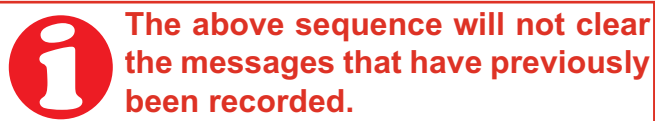

Applications

The Informa is suitable for connection to the following types of telephone line:

- a) Direct exchange lines (PSTN) supporting DTMF (tone) only.
- b) PABX exchanges, with or without secondary proceed indication.

The Informa can be used for the following:

- ❖ Automatic call initialisation
- ❖ Operation in the absence of a proceed indication.
- ❖ Automatic calling: Multiple repeat attempts.

Ringer Equivalence Number

The REN of the Informa is 1. The sum of the REN values of all telephone apparatus connected to a single line should not exceed 4.

Where the REN is not specified, it is assumed to be 1.

Factory Settings (defaults)

Engineer Code	9999
Customer Code	0123
Volume Control	Medium 1
Message Timeout	45 seconds
Input Association	Messages (1)
Trigger Levels	All inputs active low
Follow Me function	Disabled
Telephone numbers	All blank

Technical Specifications

Power supply	Provided by the host control panel
Power supply voltage	10 to 18V (max)
Power supply current	50mA quiescent, 200mA (max) when operating
Negative Input Trigger voltage	< 1.0V
Positive input Trigger voltage	3.5V to 15V (max)
Temperature range (operating)	0 to 60°C
Dialling method	DTMF (tone)
Ringer Equivalence Number	REN = 1

Using the Informa as a Standalone Unit

The Informa may be used as a standalone unit, i.e. NOT connected to an Intruder Alarm Panel. In this case, an external supply and switches can be used to operate the Inputs IP1, IP2 and IP3 to trigger the Informa. The Inputs can be configured for Active Low or Active High operation.

a) The diagram below is for an Active Low input configured using a relay to trigger IP1.

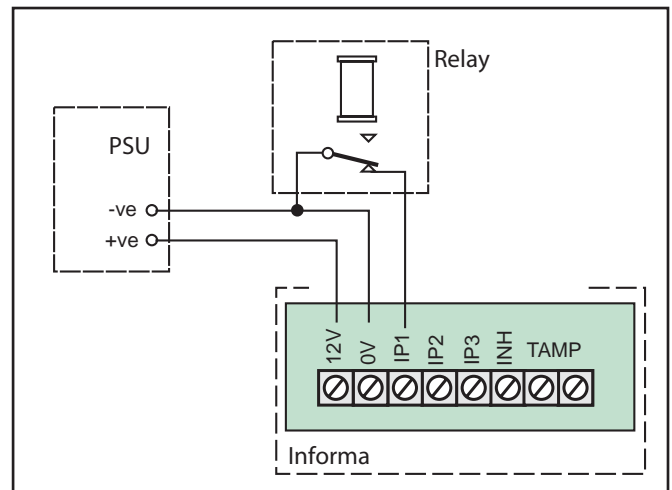
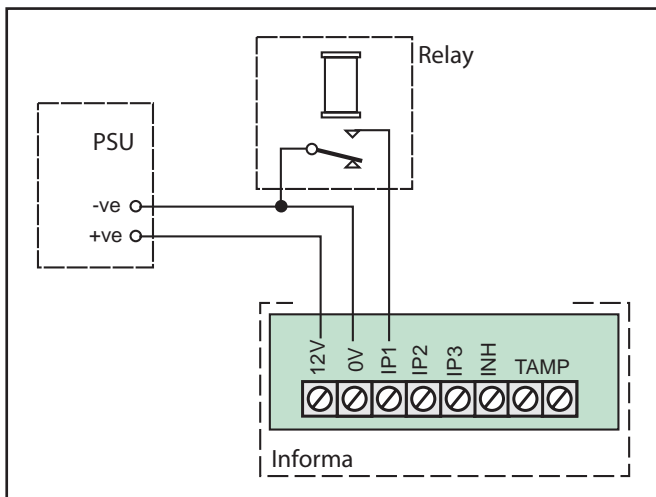

i If the Inhibit (INH) is not being used, it should be left as Active Low

b) The diagram that follows is for an Active High input configured using a relay to trigger IP1. In this case the wiring is reversed, and the inputs are connected to -ve.

Index

A

Accenta Gen 46

Acknowledgement3, 4, 12

Alarm message1, 3, 10, 11

Association, input3, 10, 13

B

‘Bells Only’6

C

Cable clamp strap5

Call, performing a test12

Connecting

 for the ‘Follow Me’ function6

 to control panels6

 to the telephone network7

Customer code11, 13

D

Dialling

 non-sequential3, 4, 10

 sequential3, 10

DTMF13, 14

E

Engineer code9, 11, 13

Engineer Programming9

F

Follow Me3, 6, 11, 12

I

INH (Inhibit Input)6, 7, 9, 10, 14, 16

Informa status9

Input3, 6, 7, 9, 10, 13, 14, 16

Inhibit Input6, 7, 9, 10, 14, 16

IP1, IP33, 4, 6, 9, 10, 14, 16

IP23, 4, 6, 14, 16

L

Last event10

Levels, trigger6, 10, 13

M

Message

 acknowledgement4, 12

 alarm1, 3, 10, 11

 location3, 4, 9, 11

 playback12

 recorded10

 recording11

 timeout10, 12, 13

N

Negative Input Trigger14

Non-sequential dialling3, 4, 10

NVM3, 13

O

Optima Compact Gen 46

P

PABX8, 12

Playback12

Positive input trigger14

PSTN7, 13

R

Recorded messages10

Recording Messages11

REN (Ringer Equivalence Number)8, 13, 14

Replaying Messages12

Reset, NVM13

Ringer Equivalence Number (REN)8, 13, 14

S

Sequential dialling3, 10

Setup

 input10

 operating3

Status, Informa9

T

Tamper

 activation5

 connections6

Telephone number1, 3, 4, 8, 10, 11, 12, 13

Test call, performing12

Timeout, message10, 12, 13

Trigger

 inputs10

 levels6, 10, 13

 Negative Input14

 Positive Input14

Quick Reference

