

Submersible Sewage Pump Type ABS XFP PE1 - PE3

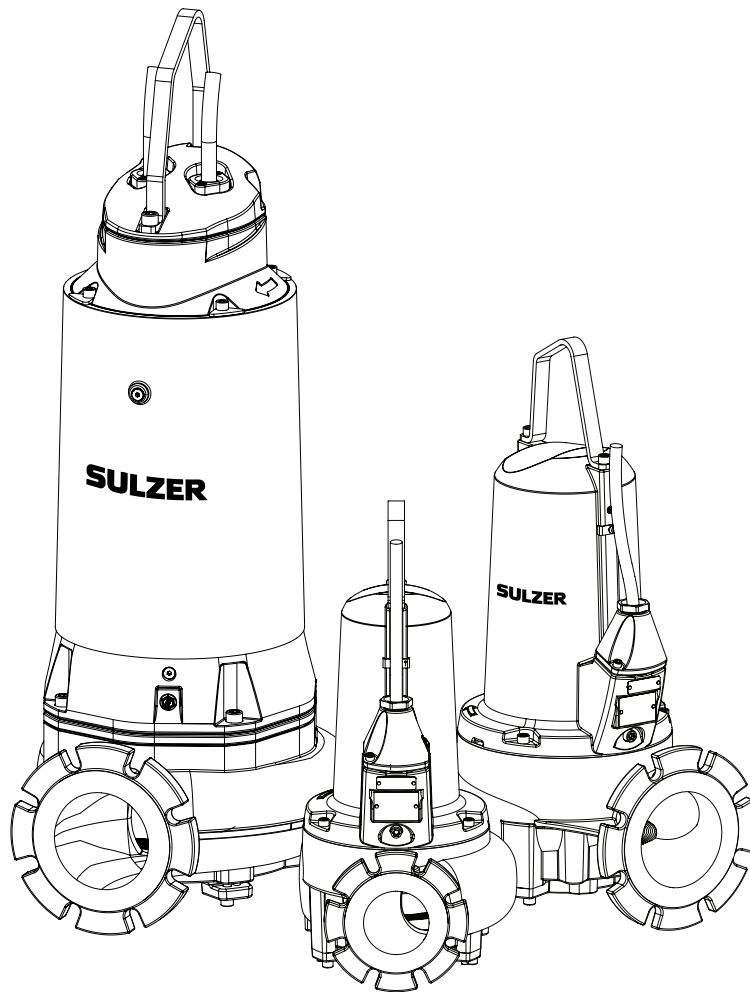

Installation and Operating Instructions (Original Instructions)

Submersible Sewage Pump Type ABS XFP PE1 - PE3

PE1 (50 Hz)		PE2 (50 Hz)		PE3 (50 Hz)		PE1 (60 Hz)		PE2 (60 Hz)		PE3 (60 Hz)	
80C-CB1	80E-CB1	100G-CB1	200G-CB1	80C-CB1	80E-CB1	100G-CB1	105J-CB2	80C-VX	81E-VX	101G-CB1	155J-CB2
80C-VX	81E-VX	100G-VX	201G-CB2	81C-VX	100E-CB1	101G-VX	206J-CB2	100C-CB1	100E-VX	150G-CB1	250J-CB2
81C-CB1	100E-CB1	101G-CB1	105J-CB2	100C-VX	100E-CP	150G-CP	255J-CB2	150E-CB1	200G-CB1	305J-CB2	
81C-VX	100E-VX	101G-VX	155J-CB2		151E-CB2	150G-CP	255J-CB2	151E-CB2	201G-CB2		
100C-CB1	100E-CP	150G-CB1	206J-CB2								
100C-VX	150E-CB1	150G-VX	250J-CB2								
	151E-CB2	150G-CP	255J-CB2								
			305J-CB2								

Contents

1	Application areas	4
1.1	Explosion-proof approvals	4
2	Safety	4
2.1	Use of explosion-proof pumps in explosive zones.....	4
2.2	Operation of explosion-proof submersible pumps with frequency inverter in hazardous areas (ATEX Zone 1 and 2).....	5
3	Technical data	5
3.1	Nameplates	5
4	General design features	6
4.1	Design features PE1 & PE2	6
4.2	Design features PE3 (version with cooling jacket).....	7
5	Weights	8
5.1	XFP - 50 Hz.....	8
5.2	XFP - 60 Hz	9
5.3	Chain (DIN 763)	10
6	Transport and storage	10
6.1	Transport.....	10
6.1.1	Horizontal lifting	10
6.2	Storage.....	11
6.2.1	Moisture protection of motor connection cable	11
7	Mounting and installation	11
7.1	Installation examples.....	12
7.1.1	Submerged in concrete sump	12
7.1.2	Dry-installed	13
7.2	Discharge Line	14
8	Electrical connection	14
8.1	Temperature monitoring	14
8.2	Seal monitoring	14
8.3	Wiring diagrams	15
9	Commissioning	16
9.1	Types of operation and frequency of starting.....	16
9.2	Checking direction of rotation	16
9.3	Changing direction of rotation	17

10	Maintenance and service	17
10.1	General maintenance instructions	17
10.2	Maintenance of lifting stations in accordance with EN 12056.....	17
10.3	Lubricant changing (PE1 & PE2).....	18
10.3.1	Instructions on how to drain and fill the oi chamber.....	18
10.4	Lubricant changing (PE3 - version without cooling jacket)	19
10.4.1	Instructions on how to drain and fill the oil chamber.....	19
10.4.2	Instructions on how to drain and fill the inspection chamber	20
10.5	Coolant changing (PE3 - version with cooling jacket).....	21
10.5.1	Instructions on how to drain and fill the cooling system.....	21
10.6	Oil and glycol quantities (litres)	22
10.7	Bottom plate adjustment (CB & CP).....	23
10.7.1	Instructions on how to adjust the bottom plate.....	23
10.8	Bearings and mechanical seals	24
10.9	Changing the power cable (PE1 & PE2)	24
10.10	Cleaning	24
10.11	Venting of the volute.....	24
11	Troubleshooting Guide	25

Symbols and notices used in this booklet:



Presence of dangerous voltage.



Non-compliance may result in personal injury.



Hot surface - danger of burn injury.



Danger of an explosion occurring.

ATTENTION! Non-observance may result in damage to the unit or negatively affect its performance.

NOTE: Important information for particular attention.

1 Application areas

XFP pumps have been designed for economic and reliable pumping in commercial, industrial and municipal installations and are suitable for pumping of the following liquids:

- clear and wastewater, and for sewage containing solids and fibrous material
- faecal matter

XFP-CP (Chopper) pumps have been designed for heavy duty applications.

In combination with the automatic coupling system, the below ground level wet installation is a particularly economical and environmentally friendly solution. The pumps are also suitable for horizontal or vertical dry installation (except XFP 80E-CB1-PE125/2-60 Hz, XFP 81E-VX-PE125/2-60 Hz, XFP 81E-VX-PE80/2-60 Hz, and XFP-CP).

The regulations of DIN 1986 as well as local regulations should be observed when installing the pump.

ATTENTION! *The maximum allowable temperature of the medium pumped is 40 °C.*

1.1 Explosion-proof approvals

Explosion-proof as standard, in accordance with international standards ATEX 2014/34/EU [II 2G Ex db IIB T4 Gb], FM and CSA [PE3, FM only] (60 Hz US).

2 Safety

The general and specific health and safety guidelines are described in detail in the "Safety Instructions for Sulzer Products Type ABS" booklet. If anything is not clear or you have any questions as to safety make certain to contact the manufacturer Sulzer.

2.1 Use of explosion-proof pumps in explosive zones.

1. Explosion-proof submersible pumps may only be operated with the thermal sensing system connected.
2. Temperature monitoring of explosion-proof submersible pumps has to be carried out by bi-metallic temperature limiters or thermistors according to DIN 44 082 connected to a suitable release device which is certified in accordance with EC directive 2014/34/EU.
3. Float switches and seal monitoring (DI) must be connected via an intrinsically safe electrical circuit, Protection Type EX (i), in accordance with IEC 60079-11.
4. Dismantling and repair of submersible explosion-proof motors may only be carried out by approved personnel in specially approved workshops.
5. In the event that the pump is to be operated in explosive atmospheres using a variable speed drive, please contact your local Sulzer representative for technical advice regarding the various approvals and standards concerning thermal overload protection.
6. Machines designated as Ex machines may never, without exception, be operated using a mains frequency that is greater than the maximum of 50 Hz or 60 Hz as indicated on the nameplate.

2.2 Operation of explosion-proof submersible pumps with frequency inverter in hazardous areas (ATEX Zone 1 and 2).

Motors must have direct thermal protection devices fitted. These consist of temperature sensors (PTC DIN 44082) embedded in the windings and must be connected to a suitable release device which is certified in accordance with EC directive 2014/34/EU.

3 Technical data

Maximum noise level ≤ 70 dB. This may be exceeded in certain circumstances.

Detailed technical information is available in the technical data sheets “Submersible Sewage Pump Type ABS XFP 80C - 201G” and “Submersible Sewage Pump Type ABS XFP 105J - 600X” that can be downloaded from www.sulzer.com > Products > Pumps > Submersible Pumps.

3.1 Nameplates

XFP pumps are rated for use in hazardous locations (Ex) as standard, and are fitted with a standard nameplate containing technical data and a secondary nameplate to certify that the pump is Ex rated (examples below). If an XFP pump is serviced or repaired in a workshop that is not Ex approved then it must no longer be used in hazardous locations and the Ex nameplate must be removed.

We recommend that you record the data from the standard nameplate on the pump in the corresponding form below, and maintain it as a source of reference for the ordering of spare parts, repeat orders and general queries.

Always state the pump type, item number and serial number in all communications.

Standard nameplate

SULZER		CE	xx/xxxx	IP 68
Typ				
Nr	Sn			
UN	IN	Ph	Hz	
P1:	Cos φ	n		
P2:	Weight			
IEC 60034-30 IE3				
Qmax	Hmax			
DN	Hmin	Ø Imp		
Sulzer Pump Solutions Ireland Ltd. Wexford, Ireland.				
Made in Ireland	www.sulzer.com			

Legend

Typ	Pump type	
Nr	Item No.	
Sn	Serial No.	
xx/xxxx	Production date (Week/Year)	
UN	Rated voltage	V
IN	Rated current	A
Ph	Number of phases	
Hz	Frequency	Hz
P1	Rated input power	kW
P2	Rated output power	kW
n	Speed	r/min
Cos φ	Power factor	pf
Weight		kg
Qmax	Maximum flow	m ³ /h
Hmax	Maximum head	m
Hmin	Minimum head	m
Ø Imp.	Impeller diameter	mm
DN	Discharge diameter	mm

Ex nameplate PE1 and PE2

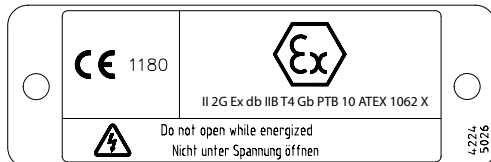

Ex nameplate PE3

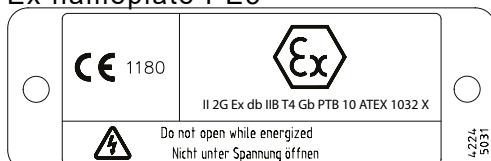

4 General design features

XFP is a submersible sewage and wastewater pump with a Premium Efficiency motor.

The water-pressure-tight, encapsulated, flood-proof motor and the pump section form a compact, robust, modular construction.

4.1 Design features PE1 & PE2

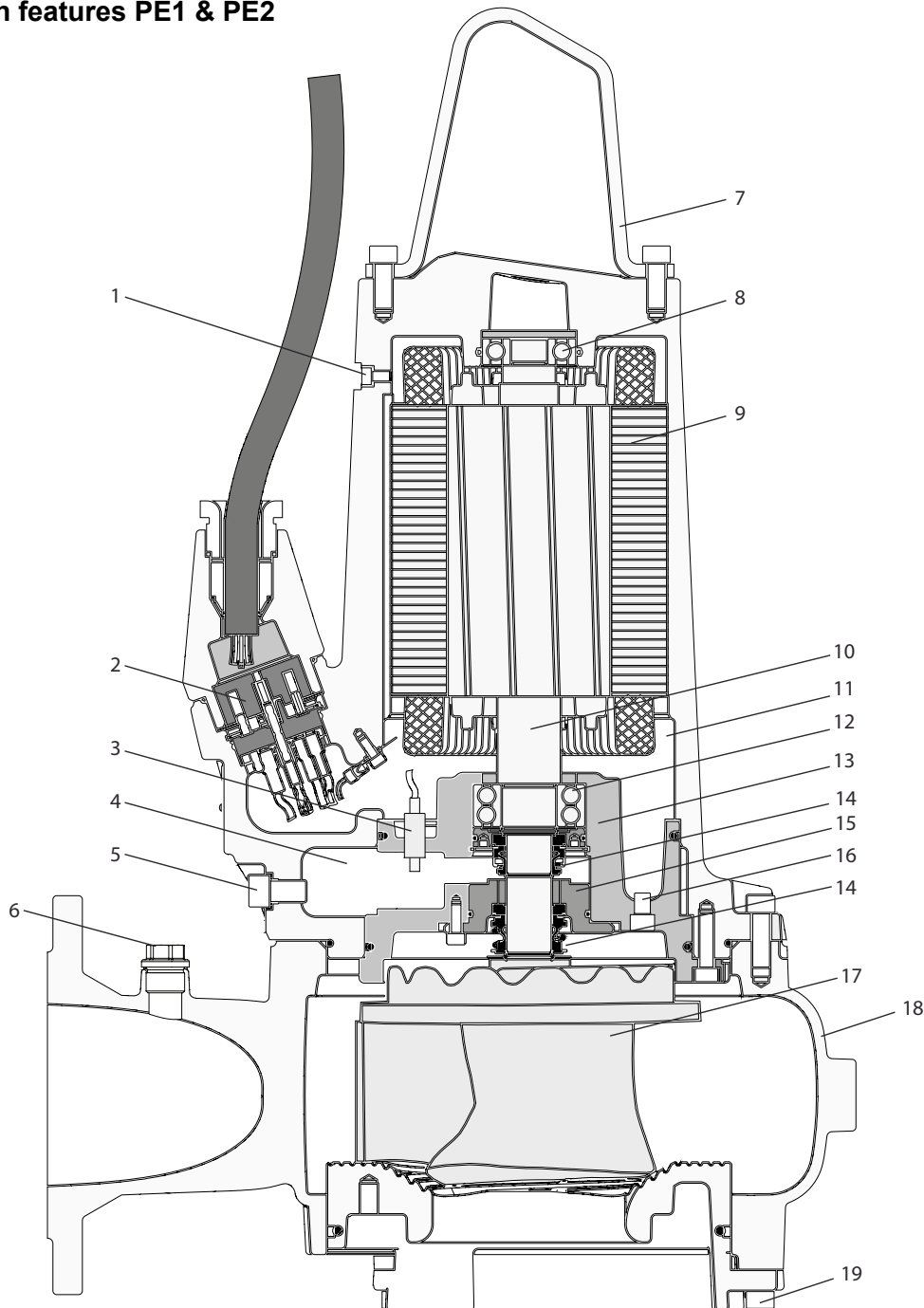

1	Pressure release screw	7	Stainless steel lifting hoop	14	Mechanical seals
2	10-pole terminal block	8	Upper bearing - single row	15	Seal holding plate
3	Moisture sensor (DI)	9	Motor with thermal sensors	16	Motor chamber drain plug/ pressure test point
4	Seal chamber	10	Stainless steel shaft	17	Impeller - Contrablock version
5	Seal chamber drain plug/ pressure test point	11	Motor chamber	18	Volute
6	Venting plug	12	Lower bearing - double row	19	Bottom plate adjustment screw
		13	Bearing housing		

4.2 Design features PE3 (version with cooling jacket)

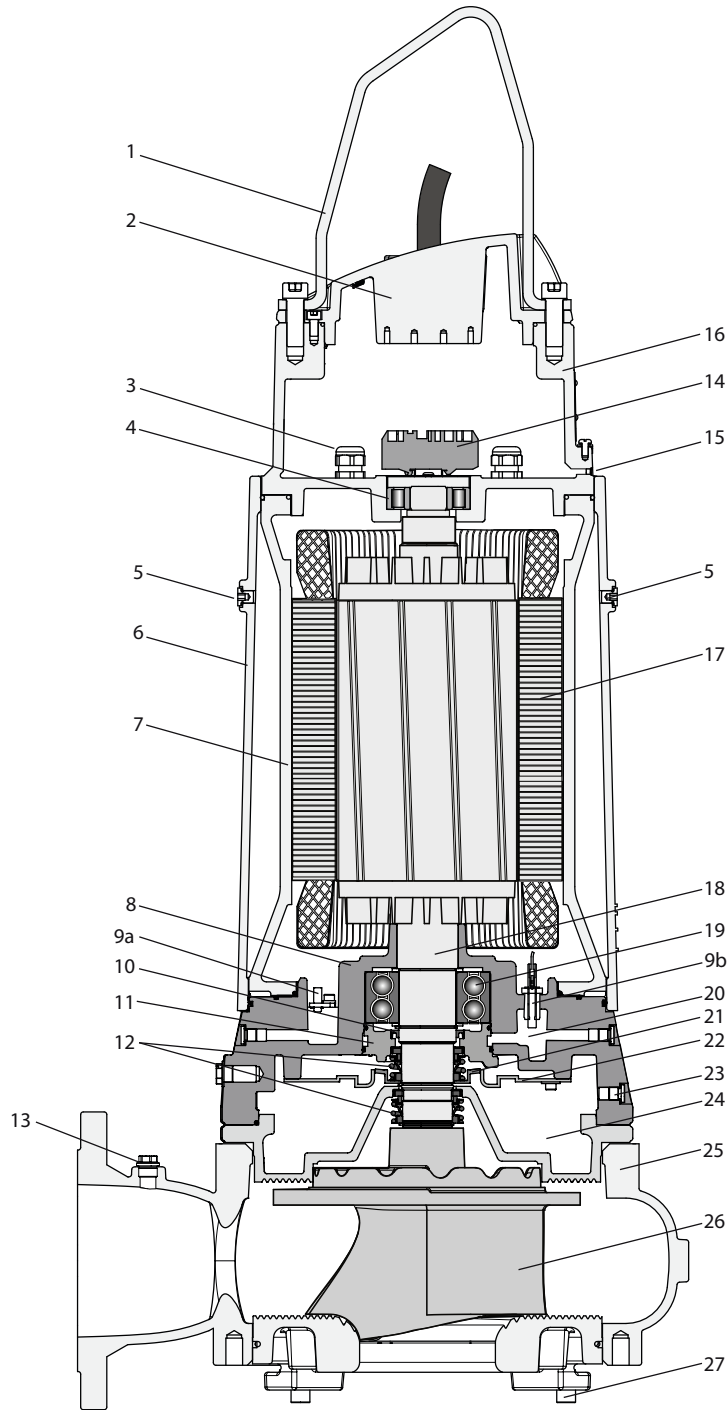

- | | | | | | |
|----|--|----|----------------------------|----|--|
| 1 | Stainless steel lifting hoop | 9b | Moisture sensor (DI) 60 Hz | 19 | Lower bearing - double row |
| 2 | Lid assembly | 10 | Lipseal | 20 | Inspection chamber |
| 3 | Cable gland | 11 | Seal holding plate | 21 | Coolant impeller |
| 4 | Upper bearing - cylindrical roller bearing | 12 | Mechanical seals | 22 | Flow deflector |
| 5 | Coolant fill plug | 13 | Venting plug | 23 | Coolant drain plug / pressure test point |
| 6 | Cooling jacket | 14 | Terminal block | 24 | Oil chamber |
| 7 | Motor housing | 15 | Pressure test point | 25 | Volute |
| 8 | Lower bearing housing | 16 | Upper bearing housing | 26 | Impeller - Contrablock version |
| 9a | Moisture sensor (DI) 50 Hz | 17 | Motor with thermal sensors | 27 | Bottom plate adjustment screw |
| | | 18 | Stainless steel shaft | | |

5 Weights

NOTE: Weight on nameplate is for pump and cable only.

5.1 XFP - 50 Hz

XFP		Pedestal bracket and fasteners	Horizontal supports*	Skirtbase (transportable)	Cable**	Pump*** (without cable)
		kg	kg	kg	kg	kg
80C-CB1	PE22/4, 13/6	8	9	10	0.3	100 / n.a.
	PE29/4	8	9	10	0.3	110 / n.a.
80C-VX	PE15/4, 22/4, 29/4	8	2	10	0.3	100 / n.a.
80E-CB1	PE70/2	8	2	10	0.4	150 / n.a.
	PE110/2	8	2	10	0.5	170 / n.a.
81C-CB1	PE40/2	8	9	10	0.4	110 / n.a.
81C-VX	PE30/2	8	2	10	0.3	110 / n.a.
	PE40/2	8	2	10	0.4	110 / n.a.
81E-VX	PE55/2, 70/2	8	3	10	0.4	130 / n.a.
	PE110/2	8	3	10	0.5	160 / n.a.
100C-CB1	PE22/4, 29/4, 13/6	12	9	10	0.3	110 / n.a.
100C-VX	PE15/4	12	2	10	0.3	100 / n.a.
	PE22/4, 29/4	12	2	10	0.3	110 / n.a.
100E-CB1	PE40/4, 60/4	12	3	11	0.4	160 / n.a.
	PE90/4	12	3	11	0.5	180 / n.a.
100E-CP	PE60/4	12	n.a.	11	0.4	170 / n.a.
	PE90/4	12	n.a.	11	0.5	190 / n.a.
100E-VX	PE40/4	12	3	11	0.4	140 / n.a.
	PE60/4	12	3	11	0.4	150 / n.a.
	PE90/4	12	3	11	0.5	170 / n.a.
100G-CB1	PE110/4, 140/4	12	12	21	0.4	330 / 380
	PE160/4, 185/4	12	12	21	0.5	350 / 400
	PE220/4	12	12	21	0.4	360 / 410
100G-VX	PE110/4, 140/4	12	12	21	0.4	320 / 370
	PE160/4, 185/4	12	12	21	0.5	340 / 390
101G-CB1	PE150/2	19	10	16	0.4	320 / 360
	PE185/2	19	10	16	0.5	320 / 360
	PE250/2	19	10	16	0.5	330 / 370
101G-VX	PE150/2	19	12	21	0.4	330 / 370
	PE185/2	19	12	21	0.5	330 / 370
	PE250/2	19	12	21	0.5	340 / 380
150E-CB1	PE40/4, 30/6	17	3	11	0.4	160 / n.a.
	PE60/4,	17	3	11	0.4	170 / n.a.
	PE90/4	17	3	11	0.5	190 / n.a.
150G-CB1	PE110/4, 140/4	20	12	21	0.4	340 / 380
	PE160/4, 185/4	20	12	21	0.5	370 / 400
	PE220/4	20	12	21	0.4	370 / 420
150G-CP	PE110/4	20	n.a.	21	0.4	320 / n.a.
150G-VX	PE110/4,	20	12	21	0.4	330 / 380
	PE140/4	20	12	21	0.4	320 / 380
	PE160/4, 185/4	20	12	21	0.5	350 / 400
151E-CB2	PE49/4, 60/4	20	3	11	0.4	170 / n.a.
	PE90/4	20	3	11	0.5	190 / n.a.
200G-CB1	PE110/4, 140/4	25	12	21	0.4	370 / 420
	PE160/4, 185/4	25	12	21	0.5	400 / 440
	PE220/4	25	12	21	0.4	410 / 460
	PE90/6	25	12	21	0.4	380 / 420
201G-CB2	PE90/6, 110/6	25	12	21	0.4	380 / 420
	PE140/6	25	12	21	0.5	390 / 440
105J-CB2	PE220/4,	19	17	50	0.5	412 / 472
	PE300/4	19	17	50	0.5	442 / 502
155J-CB2	PE220/4,	28	17	50	0.5	420 / 470
	PE300/4,	28	17	50	0.5	450 / 510
	PE185/6,	28	17	50	0.5	445 / 505
	PE220/6	28	17	50	0.5	453 / 503
206J-CB2	PE300/4,	39	17	56	0.5	487 / 547
	PE220/6,	39	17	56	0.5	494 / 554
	PE185/6	39	17	56	0.5	486 / 546
250J-CB2 & 255J-CB2	PE185/6,	53	23	81	0.5	541 / 601
	PE220/6	53	23	81	0.5	549 / 609
305J-CB2	PE185/6,	74	43	91	0.5	645 / 705
	PE220/6	74	43	91	0.5	653 / 713

* Includes adapter flange for XFP 80C-CB1 and XFP 100C-CB1. ** Weight per metre. *** Without / with cooling jacket

5.2 XFP - 60 Hz

XFP		Pedestal bracket and fasteners	Horizontal supports*	Skirtbase (transportable)	Cable**	Pump*** (without cable)
		kg (lbs)	kg (lbs)	kg (lbs)	kg (lbs)	kg (lbs)
80C-CB1	PE28/4, 35/4	8 (18)	9 (20)	10 (22)	0.2 (0.4)	110 (243) / n.a.
	PE20/6	8 (18)	9 (20)	10 (22)	0.1 (0.3)	120 (265) / n.a.
	PE28/4W	8 (18)	9 (20)	10 (22)	0.3 (0.5)	100 (221) / n.a.
	PE20/6W	8 (18)	9 (20)	10 (22)	0.2 (0.4)	120 (265) / n.a.
80C-VX	PE22/4, 35/4	8 (18)	2 (4)	10 (22)	0.1 (0.3)	110 (243) / n.a.
	PE18/4W	8 (18)	2 (4)	10 (22)	0.2 (0.4)	100 (221) / n.a.
	PE28/4W	8 (18)	2 (4)	10 (22)	0.3 (0.5)	100 (221) / n.a.
80E-CB1	PE125/2	8 (18)	2 (4)	10 (22)	0.3 (0.5)	180 (397) / n.a.
81C-VX	PE45/2	8 (18)	2 (4)	10 (22)	0.3 (0.5)	110 (243) / n.a.
81E-VX	PE80/2	8 (18)	3 (7)	10 (22)	0.2 (0.4)	130 (287) / n.a.
	PE125/2	8 (18)	3 (7)	10 (22)	0.3 (0.5)	160 (353) / n.a.
100C-CB1	PE28/4, 35/4	8 (18)	9 (20)	10 (22)	0.1 (0.3)	120 (265) / n.a.
	PE20/6	8 (18)	9 (20)	10 (22)	0.1 (0.3)	130 (287) / n.a.
	PE28/4W	8 (18)	9 (20)	10 (22)	0.3 (0.5)	120 (265) / n.a.
	PE20/6W	8 (18)	9 (20)	10 (22)	0.2 (0.4)	130 (287) / n.a.
100C-VX	PE22/4, 28/4, 35/4	12 (27)	2 (4)	10 (22)	0.1 (0.3)	110 (243) / n.a.
	PE18/4W	12 (27)	2 (4)	10 (22)	0.2 (0.4)	110 (243) / n.a.
	PE28/4W	12 (27)	2 (4)	10 (22)	0.3 (0.5)	110 (243) / n.a.
100E-CB1	PE45/4, 75/4	12 (27)	3 (7)	11 (24)	0.3 (0.5)	160 (353) / n.a.
	PE56/4	12 (27)	3 (7)	11 (24)	0.3 (0.5)	150 (331) / n.a.
	PE90/4,	12 (27)	3 (7)	11 (24)	0.3 (0.5)	180 (397) / n.a.
	PE105/4	12 (27)	3 (7)	11 (24)	0.3 (0.5)	190 (419) / n.a.
	PE35/6	12 (27)	3 (7)	11 (24)	0.2 (0.4)	170 (375) / n.a.
100E-CP	PE75/4	12 (27)	n.a.	11 (24)	0.3 (0.5)	160 (353) / n.a.
	PE105/4	12 (27)	n.a.	11 (24)	0.3 (0.5)	190 (419) / n.a.
100E-VX	PE45/4, 56/4	12 (27)	3 (7)	11 (24)	0.3 (0.5)	140 (309) / n.a.
	PE75/4	12 (27)	3 (7)	11 (24)	0.3 (0.5)	150 (331) / n.a.
	PE90/4, 105/4	12 (27)	3 (7)	11 (24)	0.3 (0.5)	170 (375) / n.a.
100G-CB1	PE130/4, 150/4	12 (27)	12 (27)	21 (46)	0.4 (0.9)	330 (728) / 370 (816)
	PE185/4, 210/4	12 (27)	12 (27)	21 (46)	0.5 (1.0)	350 (772) / 390 (860)
	PE250/4	12 (27)	12 (27)	21 (46)	0.7 (2.0)	360 (794) / 410 (904)
	PE90/6	12 (27)	12 (27)	21 (46)	0.3 (0.5)	340 (750) / 390 (860)
101G-CB1	PE185/2, 200/2	19 (42)	10 (22)	16 (35)	0.5 (1.0)	320 (706) / 360 (794)
	PE230/2	19 (42)	10 (22)	16 (35)	0.5 (1.0)	330 (728) / 370 (816)
	PE300/2	19 (42)	10 (22)	16 (35)	0.7 (2.0)	330 (728) / 370 (816)
101G-VX	PE230/2	19 (42)	12 (27)	21 (46)	0.5 (1.0)	330 (728) / 380 (838)
	PE300/2	19 (42)	12 (27)	21 (46)	0.7 (2.0)	340 (750) / 380 (838)
150E-CB1	PE45/4, 75/4	17 (38)	3 (7)	11 (24)	0.3 (0.5)	160 (353) / n.a.
	PE56/4	17 (38)	3 (7)	11 (24)	0.3 (0.5)	180 (397) / n.a.
	PE90/4,	17 (38)	3 (7)	11 (24)	0.3 (0.5)	200 (441) / n.a.
	PE105/4	17 (38)	3 (7)	11 (24)	0.3 (0.5)	200 (441) / n.a.
	PE35/6	17 (38)	3 (7)	11 (24)	0.2 (0.4)	170 (375) / n.a.
150G-CB1	PE130/4, 150/4	20 (44)	12 (27)	21 (46)	0.4 (0.9)	340 (750) / 380 (838)
	PE185/4, 210/4	20 (44)	12 (27)	21 (46)	0.5 (1.0)	360 (794) / 400 (882)
	PE110/6	20 (44)	12 (27)	21 (46)	0.4 (0.9)	340 (750) / 390 (860)
150G-CP	PE90/6	20 (44)	n.a.	21 (46)	0.3 (0.5)	340 (750) / 380 (838)
151E-CB2	PE75/4,	20 (44)	3 (7)	11 (24)	0.3 (0.5)	170 (375) / n.a.
	PE90/4	20 (44)	3 (7)	11 (24)	0.3 (0.5)	190 (419) / n.a.
	PE105/4	20 (44)	3 (7)	11 (24)	0.3 (0.5)	200 (441) / n.a.
	PE35/6	20 (44)	3 (7)	11 (24)	0.2 (0.4)	160 (353) / n.a.
200G-CB1	PE90/6, 110/6, 130/6	25 (55)	12 (27)	21 (46)	0.4 (0.9)	380 (838) / 420 (926)
201G-CB2	PE130/6, 120/8	25 (55)	12 (27)	21 (46)	0.4 (0.9)	380 (838) / 420 (926)
	PE160/6	25 (55)	12 (27)	21 (46)	0.3 (0.5)	390 (860) / 440 (970)
	PE200/6	25 (55)	12 (27)	21 (46)	0.5 (1.0)	440 (970) / 480 (1058)
105J-CB2	PE250/4,	19 (42)	17 (38)	50 (110)	0.5 (1.0)	412 (906) / 472 (1038)
	PE350/4,	19 (42)	17 (38)	50 (110)	0.5 (1.0)	442 (972) / 502 (1104)
	PE200/6,	19 (42)	17 (38)	50 (110)	0.5 (1.0)	431 (948) / 491 (1080)
	PE250/6	19 (42)	17 (38)	50 (110)	0.5 (1.0)	445 (979) / 505 (1111)
155J-CB2	PE250/4,	28 (62)	17 (38)	50 (110)	0.5 (1.0)	420 (924) / 470 (1034)
	PE350/4,	28 (62)	17 (38)	50 (110)	0.5 (1.0)	450 (990) / 510 (1122)
	PE200/6,	28 (62)	17 (38)	50 (110)	0.5 (1.0)	445 (979) / 505 (1111)
	PE250/6	28 (62)	17 (38)	50 (110)	0.5 (1.0)	453 (996) / 503 (1106)
206J-CB2	PE200/6	39 (86)	17 (38)	56 (124)	0.5 (1.0)	416 (913) / 546 (1201)
	PE250/6	39 (86)	17 (38)	56 (124)	0.5 (1.0)	494 (1086) / 554 (1218)
250J-CB2 & PE200/6		53 (117)	23 (51)	81 (179)	0.5 (1.0)	541 (1190) / 601 (1322)
255J-CB2	PE250/6	53 (117)	23 (51)	81 (179)	0.5 (1.0)	549 (1207) / 609 (1339)
305J-CB2	PE200/6,	74 (163)	43 (95)	91 (201)	0.5 (1.0)	645 (1419) / 705 (1551)
	PE250/6	74 (163)	43 (95)	91 (201)	0.5 (1.0)	653 (1346) / 713 (1568)

* Includes adapter flange for XFP 80C-CB1 and XFP 100C-CB1. ** Weight per ft. *** Without / with cooling jacket

5.3 Chain (DIN 763)

Size (mm)	5 x 35	6 x 42	8 x 52	10 x 65	13 x 82
Weight per metre (kg)	0.43	0.63	1.10	1.75	2.95



Weights of accessories, other than or in addition to those listed, must also be included when specifying the working load of any lifting equipment. Please consult with your local Sulzer representative prior to installation.

6 Transport and storage

6.1 Transport

During transport, care should be taken that the pump is not dropped or thrown.

The pumps of the XFP series are fitted with a lifting hoop to which a chain and shackle can be attached for transport or for suspension of the pump. For horizontal lifting, screw holes are provided for the fitting of an eye bolt to which the chain and shackle is attached in addition to attaching to the lifting hoop (see 6.1.1).



The pump must be raised only by the lifting hoop and never by the power cable.



Take note of the weight of the entire unit. The hoist and chain must be adequately dimensioned for that weight and must comply with the current valid safety regulations.

All relevant safety regulations as well as general good technical practice must be complied with.

6.1.1 Horizontal lifting

XFP pumps can be fitted with eyebolts for horizontal lifting. Screw holes are provided in the volute or bearing housing, depending on the pump model (see location points and sizes below).

XFP 80C - 151E (PE1 & 2)

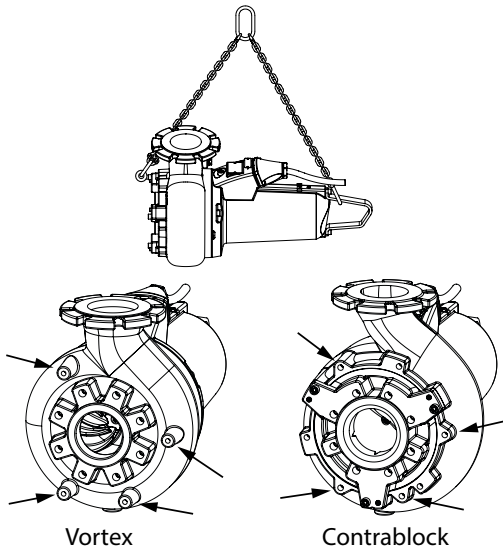

XFP 100G - 305J (PE3)

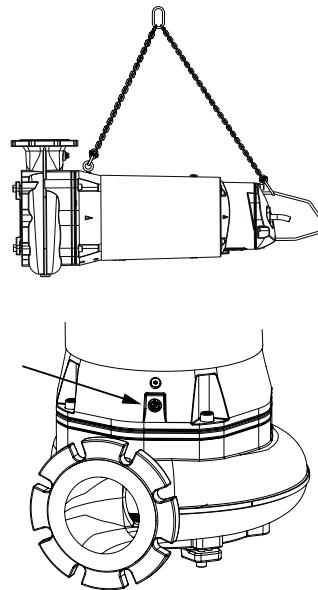

XFP	80C - 100C, 80E, 81E, 100E(VX)	100E(CB) - 151E	100G - 305J
Eyebolt size	M10	M12	M16



For angular lifting, shoulder-type machinery eyebolts rated to take loads $\leq 90^\circ$ must be used and the workload must be adjusted accordingly. The eyebolt must be firmly seated and the load must always be applied in the plane of the eye and not at an angle to it.

6.2 Storage

1. During long periods of storage the pump should be protected from moisture and extremes of cold or heat.
2. To prevent the mechanical seals from sticking it is recommended that occasionally the impeller is rotated by hand.
3. If the pump is being taken out of service the oil should be changed before storage.
4. After storage the pump should be inspected for damage, the oil level should be checked, and the impeller checked to ensure it rotates freely.

6.2.1 Moisture protection of motor connection cable

The motor connection cables are protected against the ingress of moisture along the cable by having the ends sealed at the factory with protective covers.

ATTENTION! *The ends of the cables should never be immersed in water as the protective covers only provide protection against water spray or similar (IP44) and are not a water tight seal. The covers should only be removed immediately prior to connecting the pumps electrically.*

During storage or installation, prior to the laying and connection of the power cable, particular attention should be given to the prevention of water damage in locations which could flood.

ATTENTION! *If there is a possibility of water ingress then the cable should be secured so that the end is above the maximum possible flood level. Take care not to damage the cable or its insulation when doing this.*

7 Mounting and installation

The following guidelines must be observed when setting the lowest switch off point for XFP pumps:

- Care must be taken during switching on and operation that the hydraulic section is filled with water (dry installation) or alternatively is submerged or under water (wet installation). Other types of operation e.g. snore operation or dry running are not allowed!.
- The minimum submergence allowed for specific pumps can be found on the dimension installation sheets available from your local Sulzer representative.



The regulations covering the use of pumps in sewage applications, together with all regulations involving the use of explosion-proof motors, should be observed. The cable ducting to the control panel should be sealed off in a gas-tight manner by the use of a foaming material after the cable and control circuits have been pulled through. In particular the safety regulations covering work in enclosed areas in sewage plants should be observed together with general good technical practice.



In pump stations/tanks, equipotential bonding must be carried out according to EN 60079-14:2014 [Ex] or IEC 60364-5-54 [non-Ex] (Regulations for the installation of pipelines, protective measures in high voltage systems).

For the XFP transportable version, arrange the cable run so that the cables will not be kinked or nipped. Connect the discharge pipe and cable (see section "Electrical connection"). Place the pump on a firm surface which will prevent it from overturning or burrowing down. The pump can also be bolted down to the base or suspended slightly by the lifting handle. Hoses, pipes and valves must be sized to suit the pump performance.

7.1 Installation examples

7.1.1 Submerged in concrete sump

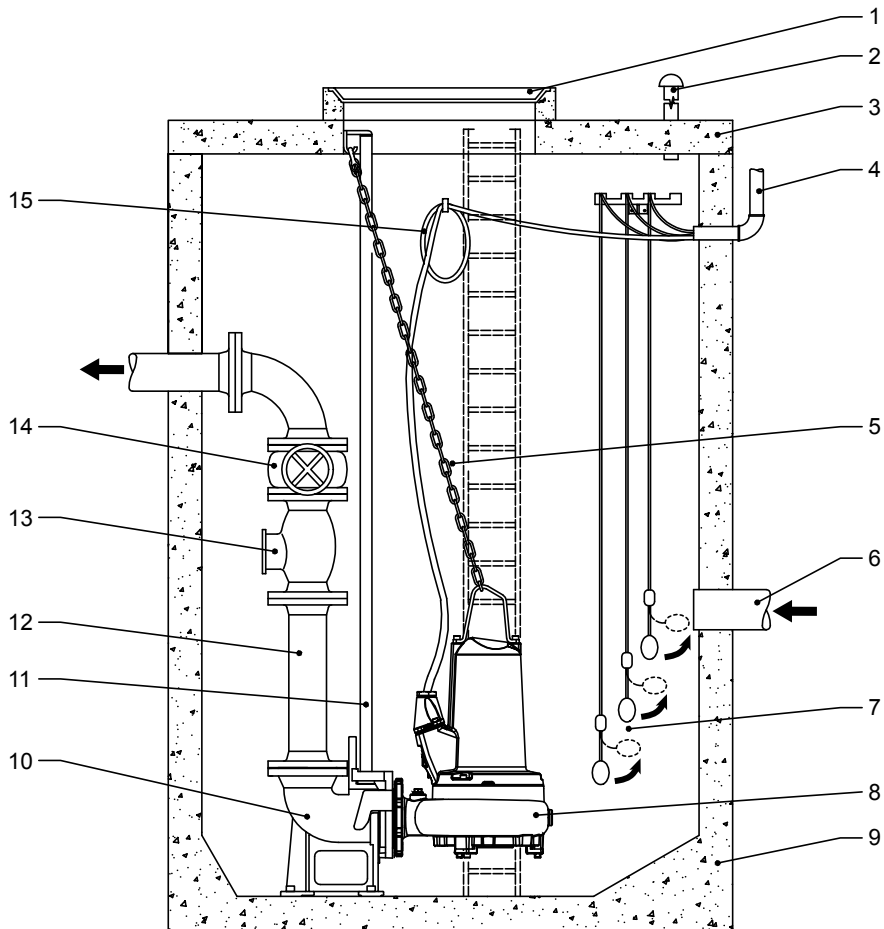

- | | | | | | |
|---|---|----|------------------------|----|----------------------|
| 1 | Sump cover | 6 | Inflow line | 11 | Guide rail |
| 2 | Venting line | 7 | Ball-type float switch | 12 | Discharge line |
| 3 | Sump cover | 8 | Submersible pump | 13 | Non-return valve |
| 4 | Sleeve for cable ducting to the control panel as well as for aeration and venting | 9 | Concrete sump | 14 | Gate valve |
| 5 | Chain | 10 | Pedestal | 15 | Power cable to motor |

7.1.2 Dry-installed

Horizontal

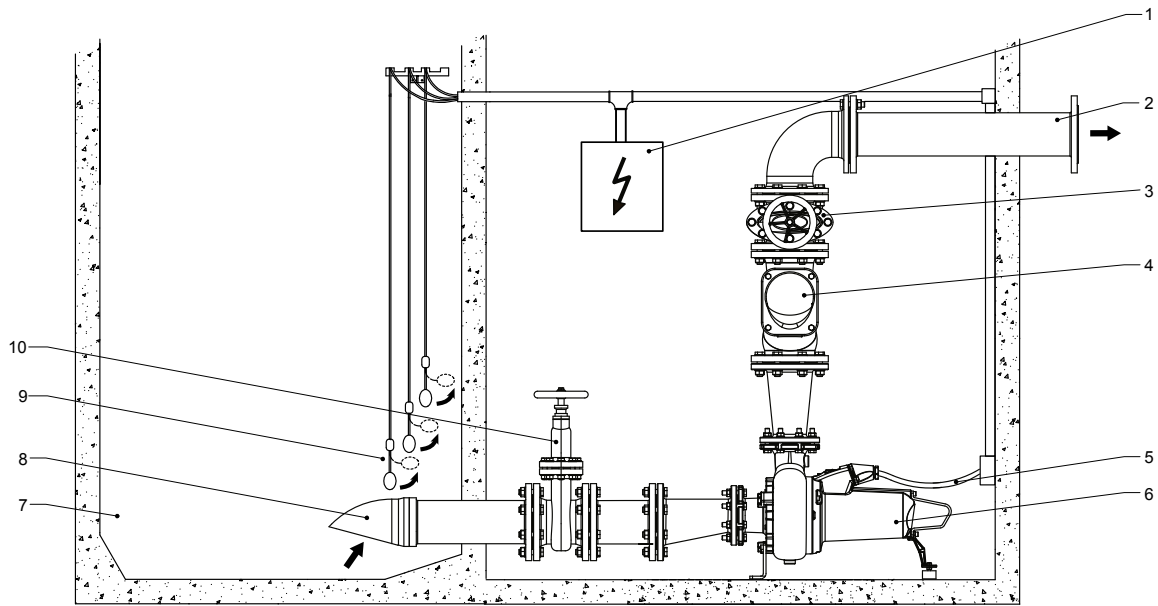

Vertical

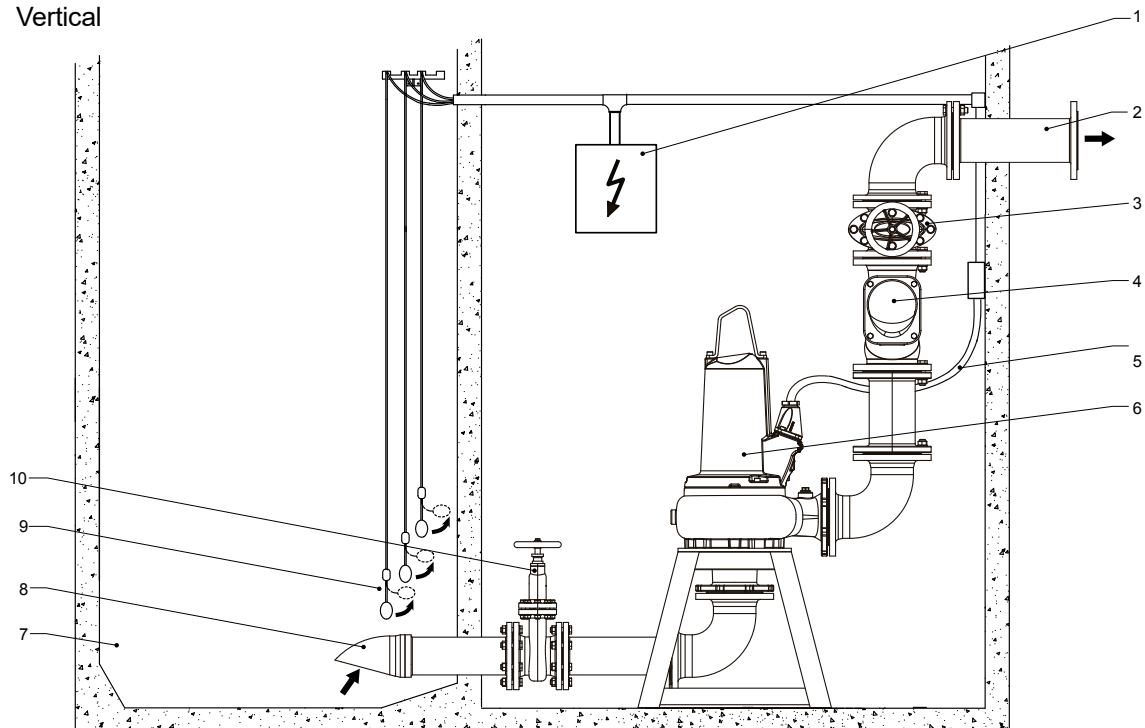

- | | | | | | |
|---|----------------|---|---|----|------------------------|
| 1 | Control panel | 4 | Non-return valve | 7 | Collection sump |
| 2 | Discharge line | 5 | Power cable from motor to control panel | 8 | Inflow line |
| 3 | Gate valve | 6 | Pump | 9 | Ball-type float switch |
| | | | | 10 | Gate valve |

ATTENTION! PE3 pumps must not be dry-installed without a cooling jacket.



When dry-installed the pump motor housing may become hot. In such a case, to avoid burn injury, allow to cool down before handling.

7.2 Discharge Line

The discharge line must be installed in compliance with the relevant regulations. DIN 1986/100 and EN 12056 applies in particular to the following:

- The discharge line should be fitted with a backwash loop (180° bend) located above the backwash level and should then flow by gravity into the collection line or sewer.
- The discharge line should not be connected to a down pipe.
- No other inflows or discharge lines should be connected to this discharge line.

ATTENTION! *The discharge line should be installed so that it is not affected by frost.*

8 Electrical connection



Before commissioning, an expert should check that one of the necessary electrical protective devices is available. Earthing, neutral, earth leakage circuit breakers, etc. must comply with the regulations of the local electricity supply authority and a qualified person should check that these are in perfect order.

ATTENTION! *The power supply system on site must comply with local regulations with regard to cross-sectional area and maximum voltage drop. The voltage stated on the nameplate of the pump must correspond to that of the mains.*

The power supply cable must be protected by an adequately dimensioned slow-blow fuse corresponding to the rated power of the pump.



The incoming power supply as well as the connection of the pump itself to the terminals on the control panel must comply with the circuit diagram of the control panel as well as the motor connection diagrams and must be carried out by a qualified person.

All relevant safety regulations as well as general good technical practice must be complied with.

ATTENTION! *For use in the open air, the following regulations apply:*

Submersible pumps used outdoors must be fitted with a power cable of at least 10 metre length. Other regulations may apply in different countries.

In all installations, the power supply to the pump must be via a residual current device (e.g. RCD, ELCB, RCBO etc.) with a rated residual operating current not exceeding 30 mA. For installations not having a fixed residual current device the pump must be plugged into the power supply through a portable version of the device.

Please consult your electrician.

8.1 Temperature monitoring

Thermal sensors in the stator windings protect the motor from overheating.

XFP motors are fitted with bimetallic thermal sensors in the stator as standard, or as an option with a PTC thermistor (in accordance with DIN 44082). PTC relays for use in control panels must also be in accordance with this standard.

8.2 Seal monitoring

XFP pumps are supplied as standard with a moisture sensor (DI), to detect and alert to the ingress of water into the motor and seal chambers (PE1 & PE2), motor (PE3, 50 Hz), or motor and oil chambers (PE3, 60 Hz).

ATTENTION! *If the DI seal monitoring is activated the unit must be immediately taken out of service. Please contact your Sulzer Service Centre.*

NOTE: *Running the pump with the thermal and/or moisture sensors disconnected will invalidate related warranty claims.*

8.3 Wiring diagrams

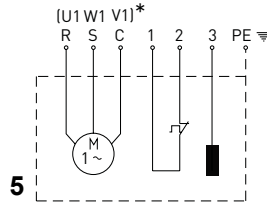
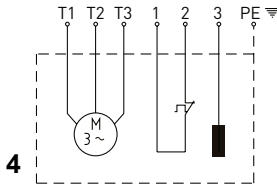
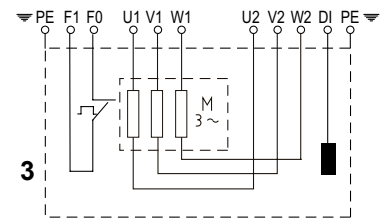
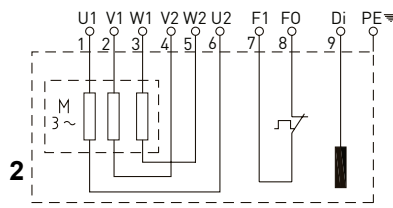
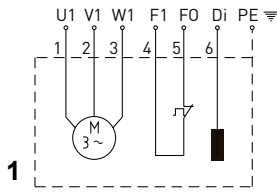

Explosion-proof pumps may only be used in explosive zones with the thermal sensors connected (leads F0 & F1).

50 Hz	1	2	3	60 Hz	1	2	3	4	5	
13/6 15/4 22/4 29/4 30/2	D01, D14, D07	-	-	20/6 22/4 28/4 35/4	D68, D80	-	-	D66, D62, D77, D85	-	
40/2	-	D05, D08, D20	-	45/2	D80	D64, D67, D81	-	D66, D62, D77, D85, D86	-	
30/6	D01, D14, D07	D05	-	18/4W 28/4W 20/6W*	-	-	-	-	W60, W62	
40/4 49/4 60/4 90/4 55/2 70/2 110/2	-	D05, D08, D20	-	35/6 45/4 56/4 75/4 90/4 105/4 80/2 125/2	-	D64, D67, D81	-	D66, D62, D77, D85, D86	-	
90/6 110/6 140/6	-	D05, D08	D20	120/8 90/6 110/6 130/6	-	D64, D67	D81	D66, D62, D77, D85, D86	-	
110/4	-	D05, D08, D20	-	160/6	-	D67	D64, D81	-	-	
140/4 160/4 185/4	-	D05, D08	D20	200/6	-	-	D64, D67, D81	-	-	
220/4	-	D08	D05, D20	130/4	-	D64, D67	D81	-	-	
150/2 185/2	-	D05, D08	D20	150/4 185/4	-	-	D64, D81	-	-	
250/2 185/6	-	D08	D05, D20	210/4 250/4	-	D67	D64, D67, D81	D66, D62, D77, D85, D86	-	
300/4 220/6	-	-	D05, D08	185/2 200/2	-	-	D64, D81	-	-	
D01 = 400 V 3~, DOL		D05 = 400 V 3~, YΔ		230/2 300/2	-	-	D64, D67, D81	-	-	
D14 = 230 V 3~, DOL		D20 = 230 V 3~, YΔ		250/6	-	-	D64, D67, D81	-	-	
D07 = 500 V 3~, DOL		D08 = 500 V 3~, YΔ		350/4	-	-	D64, D67	D85, D86	-	
D18 = 695 V 3~, DOL				D62 = 230 V 3~, DOL		D68 = 380 V 3~, DOL		D81 = 220 V 3~, YΔ		W60 = 230 V 1~
				D64 = 380 V 3~, YΔ		D77 = 460 V 3~, DOL		D85 = 600 V 3~, DOL		W62 = 208 V 1~
				D66 = 208 V 3~, DOL		D80 = 220 V 3~, DOL		D86 = 460 V 3~, DOL		
				D67 = 460 V 3~, YΔ						

9 Commissioning

Before commissioning, the pump should be checked and a functional test carried out. Particular attention should be paid to the following:

- Have the electrical connections been carried out in accordance with regulations?
- Have the thermal sensors been connected?
- Is the seal monitoring device correctly installed?
- Is the motor overload switch correctly set?
- Does the pump sit correctly on the pedestal?
- Is the direction of rotation of the pump correct - even if run via an emergency generator?
- Are the switching ON and switching OFF levels set correctly?
- Are the level control switches functioning correctly?
- Are the required gate valves (where fitted) open?
- Do the non-return valves (where fitted) function easily?
- Has the volute been vented (see Sec. 10.11)?

9.1 Types of operation and frequency of starting

All pumps of the XFP series have been designed for continuous operation S1 when either submerged or dry-installed.

The maximum allowable starts per hour is 15, at intervals of 4 minutes.

9.2 Checking direction of rotation

When three phase units are being commissioned for the first time, and also when used on a new site, the direction of rotation must be carefully checked by a qualified person.



When checking the direction of rotation, the pump should be secured in such a manner that no danger to personnel is caused by the rotating impeller or by the resulting air flow. Do not place your hand into the hydraulic system!



When checking the direction of rotation, or when starting the unit, pay attention to the **START REACTION**. This can be very powerful and cause the pump to jerk in the opposite direction to the direction of rotation.

ATTENTION:

When viewed from above, the direction of rotation is correct if the impeller rotates in a clockwise manner.



NOTE:

The start reaction is anti-clockwise.

ATTENTION! *If a number of pumps are connected to a single control panel then each unit must be individually checked.*

ATTENTION! *The mains supply to the control panel should have a clockwise rotation. If the leads are connected in accordance with the circuit diagram and lead designations, the direction of rotation will be correct.*

9.3 Changing direction of rotation



The direction of rotation should only be altered by a qualified person.

If the direction of rotation is incorrect then this is altered by changing over two phases of the power supply cable in the control panel. The direction of rotation should then be rechecked.

10 Maintenance and service



Before commencing any maintenance work the pump should be completely disconnected from the mains by a qualified person and care should be taken that it cannot be inadvertently switched back on.



When carrying out any repair or maintenance work, the safety regulations covering work in enclosed areas of sewage installations as well as good general technical practices should be followed.



Servicing must only be carried out by qualified personnel.



Under continuous running conditions the pump motor housing can become very hot. To prevent burn injury allow to cool down before handling.

ATTENTION! *The maintenance instructions given here are not designed for “do-it-yourself” repairs as special technical knowledge is required.*

10.1 General maintenance instructions

Sulzer submersible pumps are reliable quality products, each being subjected to careful final inspection. Lubricated-for-life ball bearings, together with monitoring devices, ensure optimum pump reliability provided that the pump has been connected and operated in accordance with the operating instructions. However, should a malfunction occur, do not improvise, but ask your Sulzer Customer Service Department for assistance. This applies particularly if the pump is continually switched off by the current overload in the control panel, by the thermal sensors of the thermo-control system, or by the seal monitoring system (DI).

Regular inspection and care is recommended to ensure a long service life. Service intervals vary for XFP pumps depending on installation and application. For recommended service interval details contact your local Sulzer Service Centre. A maintenance contract with our Service Department will guarantee the best technical service.

When carrying out repairs, only original spare parts supplied by the manufacturer should be used. Sulzer warranty conditions are only valid provided that any repair work has been carried out in a Sulzer approved workshop and where original Sulzer spare parts have been used.

NOTE: *XFP pumps are rated for use in hazardous locations (Ex) as standard and feature a secondary Ex nameplate containing EX data. If an XFP pump is serviced or repaired in a workshop that is not Ex-approved then it must no longer be used in hazardous locations and the Ex nameplate must be removed.*

ATTENTION! *Repair work on explosion-proof motors may only be carried out in authorized workshops by qualified personnel using original parts supplied by the manufacturer. Otherwise the Ex-approvals are no longer valid. Detailed guidelines, instructions and dimensional drawings for the service and repair of Ex-approved pumps are in the XFP 80C - 201G Workshop Manual.*

10.2 Maintenance of lifting stations in accordance with EN 12056.

It is recommended that a lifting station is inspected monthly and its function checked. In accordance with EN regulations, the lifting station should be maintained by a qualified person at the following intervals:

- in commercial premises - every three months.
- in apartment blocks - every six months.
- in a single family home - once a year.

In addition we recommend that a maintenance contract be taken out with a qualified company.

10.3 Lubricant changing (PE1 & PE2)

The seal chamber between the motor and the hydraulic section has been filled with oil at manufacture.

An oil change is only necessary:

- At specified service intervals (for details contact your local Sulzer Service Centre).
- If the DI moisture sensor detects an ingress of water into the seal chamber or motor chamber.
- After repair work that requires draining of the oil.
- If the pump is being taken out of service the oil should be changed before storage.

10.3.1 Instructions on how to drain and fill the oil chamber

1. Loosen the drain plug screw (a) enough to release any pressure that may have built-up, and re-tighten.



Before doing so, place a cloth over the plug screw to contain any possible spray of oil as the pump de-pressurises.

2. Place the pump in a horizontal position, sitting on its discharge flange, with the motor housing supported from underneath.



To prevent the pump from toppling over ensure it is supported to lie flat on its discharge flange.

3. Position an adequate container to receive the waste oil.
4. Remove the plug screw and seal ring (a) from the drain hole.
5. After the oil is fully drained lay the pump flat, and rotate so that the drain hole is positioned to the top.



When in this position the pump must be held by hand, or supported at both sides, to prevent it from toppling over.

6. Select the required volume of oil from the quantities table (p.22) and slowly pour into the drain hole.
7. Refit the plug screw and seal ring.

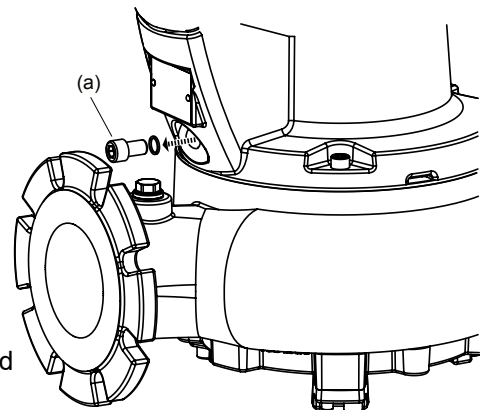

(a) Drain plug screw

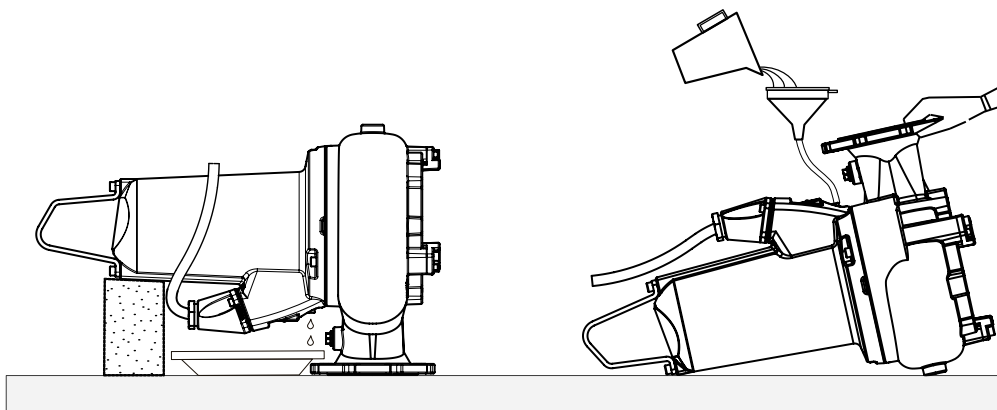

DRAIN

FILL

10.4 Lubricant changing (PE3 - version without cooling jacket)

An oil change is only necessary:

- At specified service intervals (for details contact your local Sulzer Service Centre).
- If the DI moisture sensor detects an ingress of water into the motor chamber or oil chamber.
- After repair work that requires draining of the oil.
- If the pump is being taken out of service the oil should be changed before storage.

10.4.1 Instructions on how to drain and fill the oil chamber

1. Loosen the drain plug screw (a) enough to release any pressure that may have built-up, and re-tighten.



Before doing so, place a cloth over the plug screw to contain any possible spray of oil as the pump de-pressurises.

2. Secure a hoist to the lifting hoop. Lay the pump on its side and rotate until the drain plug is underneath.

Note: because there is insufficient space to place a waste container underneath the drain plug the waste must be drained into a sump.

3. Remove the plug screw and seal ring (a) from the drain hole.
4. After the oil is fully drained, place the pump in a horizontal position sitting on its discharge flange with the motor housing supported from underneath.



To prevent the pump from toppling over ensure it is supported to lie flat on its discharge flange.

5. Select the required volume of oil from the quantities table (p.22) and slowly pour into the drain hole.
6. Refit the plug screw and seal ring.

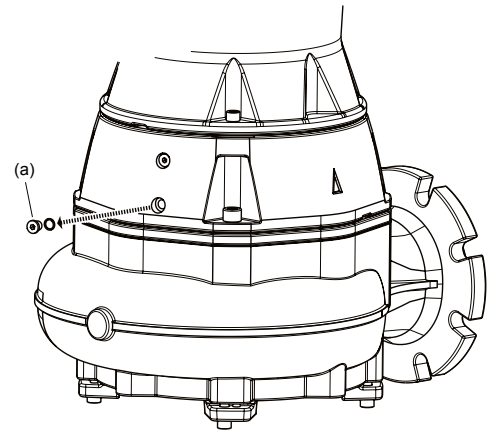

(a) Drain plug screw

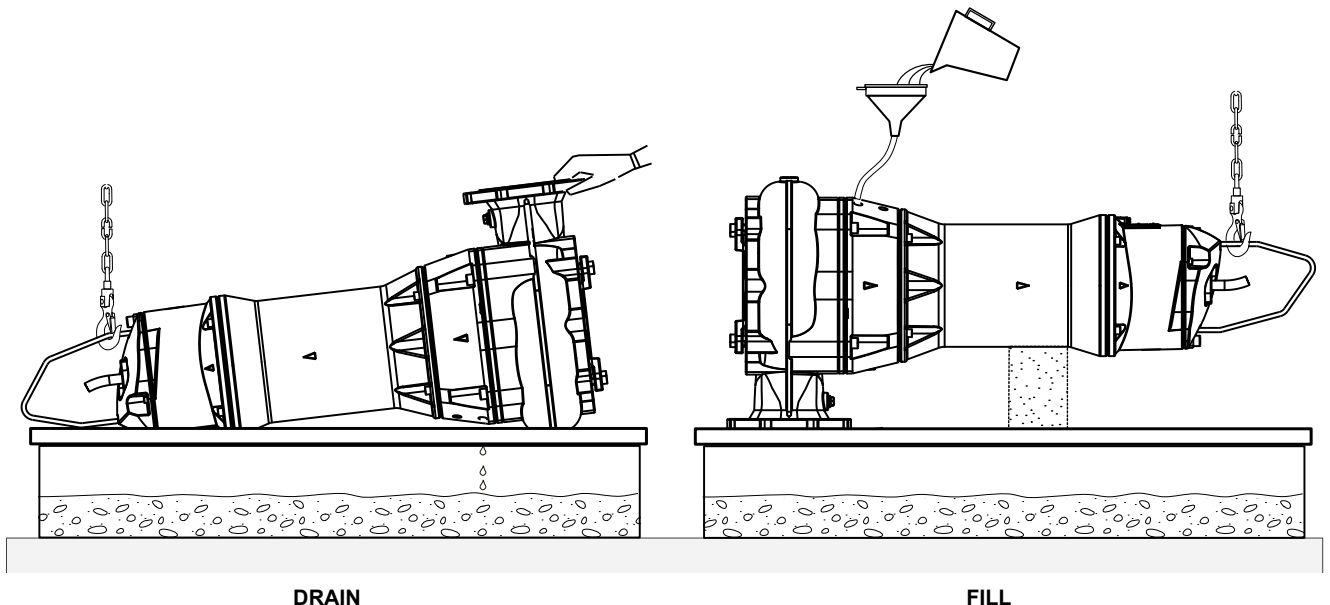

10.4.2 Instructions on how to drain and fill the inspection chamber

1. Loosen the drain plug screw (a) enough to release any pressure that may have built-up, and re-tighten.

 Before doing so, place a cloth over the plug screw to contain any possible spray of oil as the pump de-pressurises.

2. Secure a hoist to the lifting hoop. Lay the pump on its side and rotate until the drain plug is underneath.

Note: because there is insufficient space to place a waste container underneath the drain plug the waste must be drained into a sump.

3. Remove the plug screw and seal ring (a) from the drain hole.
4. After the oil is fully drained, place the pump in a horizontal position sitting on its discharge flange with the motor housing supported from underneath.

 To prevent the pump from toppling over ensure it is supported to lie flat on its discharge flange.

5. Select the required volume of oil from the quantities table (p.22) and slowly pour into the drain hole.
6. Refit the plug screw and seal ring.

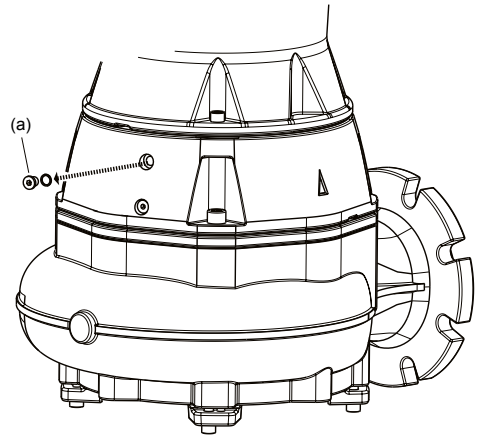

(a) Drain plug screw

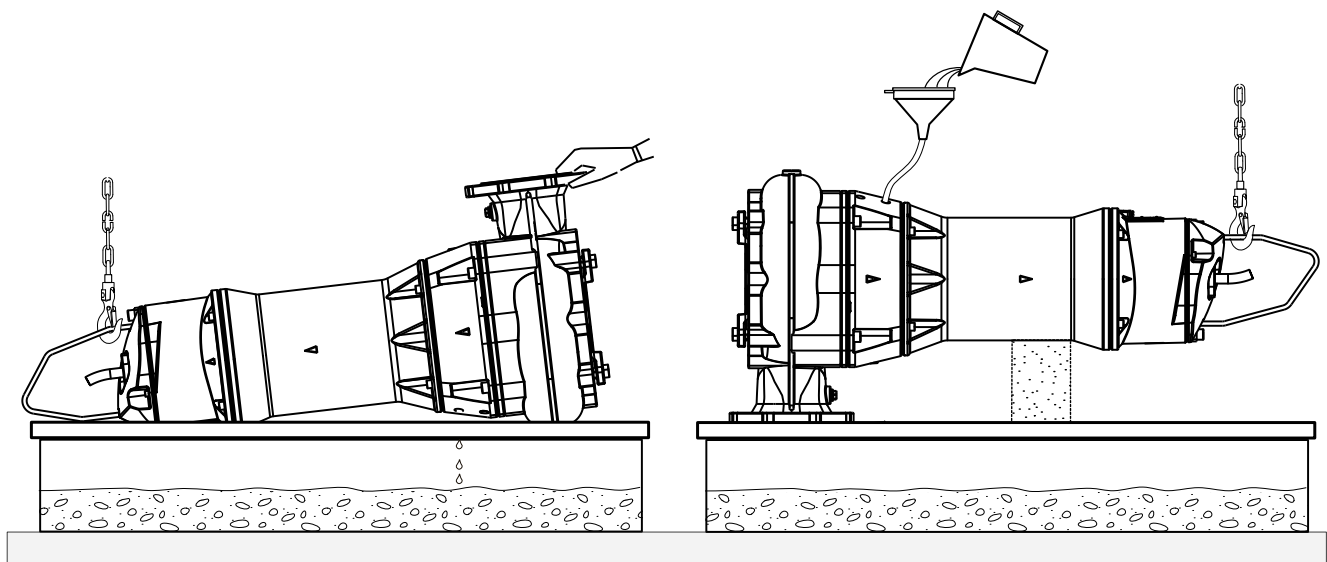

DRAIN

FILL

10.5 Coolant changing (PE3 - version with cooling jacket)

The cooling system (seal chamber and cooling jacket) has been filled with glycol at manufacture. The water and propylene glycol is frost resisting down to $-15\text{ }^{\circ}\text{C} / 5\text{ }^{\circ}\text{F}$.

A glycol change is only necessary:

- At specified service intervals (for details contact your local Sulzer Service Centre).
- If the DI moisture sensor detects an ingress of water into the motor chamber or oil chamber.
- After repair work that requires draining of the glycol.
- If the pump is being taken out of service the glycol should be changed before storage.
- In the case of extreme ambient temperatures below $-15\text{ }^{\circ}\text{C} / 5\text{ }^{\circ}\text{F}$ (e.g. during transport, storage, or if the pump is out of duty) the cooling liquid must be drained. Otherwise the pump may be damaged.

10.5.1 Instructions on how to drain and fill the cooling system

1. Loosen the plug screw (a) or (b), enough to release any pressure that may have built-up, and re-tighten.



Before doing so, place a cloth over the plug screw to contain any possible spray of glycol as the pump de-pressurises.

2. Secure a hoist to the lifting hoop. Tilt the pump to 45° with the drain plug underneath.

Note: because there is insufficient space to place a waste container underneath the drain plug by the completion of step 5, the waste must be drained into a sump.

3. Remove the plug screw and seal ring (a) from the drain hole.
4. Glycol will drain from the cooling jacket chamber.
5. When the flow stops, continue to gradually tilt the pump until horizontal. This will drain the remaining glycol from the seal chamber.

Note: draining the glycol entirely with the pump in a horizontal position would result in some glycol being retained in the cooling jacket.

6. After the glycol is fully drained raise the pump into its upright position and refit the plug screw and seal ring (a).
7. Remove the plug screw and seal ring (b) from the fill hole.
8. Select the required volume of glycol from the quantities table (p.22) and slowly pour into the fill hole.
9. Refit the plug screw and seal ring (b).

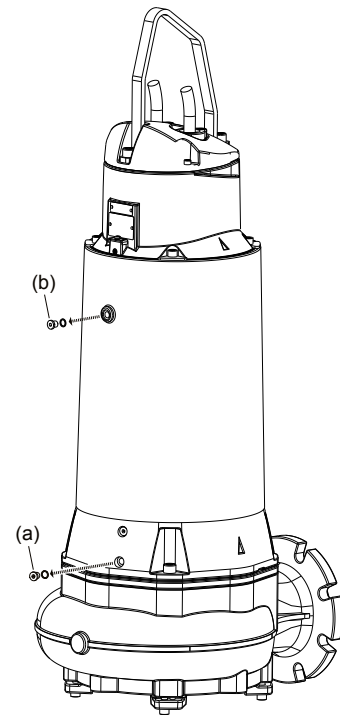

(a) Drain (b) Fill

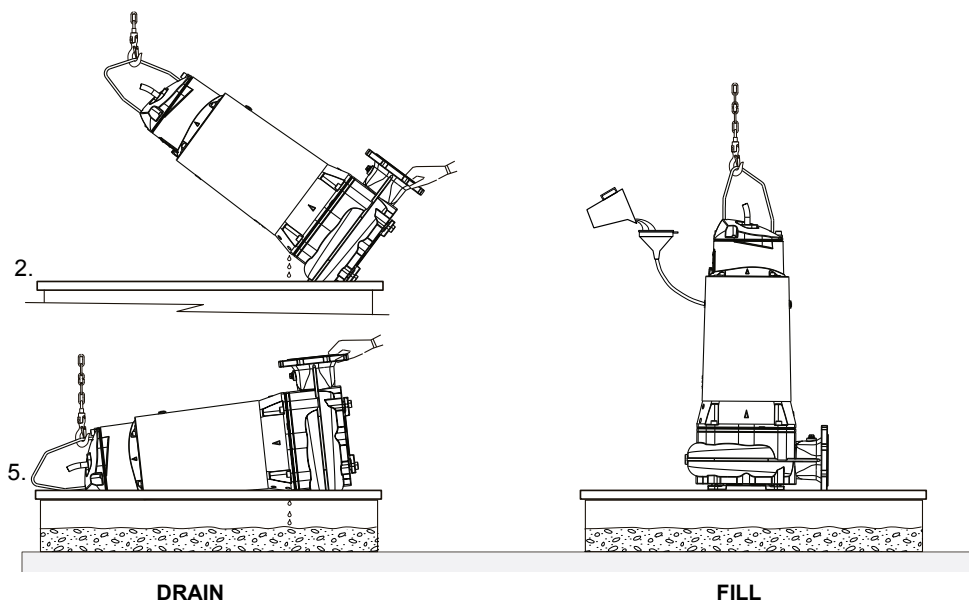

10.6 Oil and glycol quantities (litres)

XFP	Motor		Lubricant (without cooling jacket)		Coolant (with cooling jacket)
	50Hz	60Hz	Oil		Water and propylene glycol
PE 1	PE30/2	PE45/2	0.43		-
	PE40/2	PE22/4			
	PE15/4	PE28/4			
	PE22/4	PE35/4			
	PE29/4	PE18/4W			
	PE13/6	PE28/4W			
		PE20/6 PE20/6W			
PE 2	PE55/2	PE80/2	0.68		-
	PE70/2	PE125/2			
	PE110/2	PE45/4			
	PE40/4	PE56/4			
	PE49/4	PE75/4			
	PE60/4	PE90/4			
	PE90/4	PE105/4			
	PE30/6	PE35/6			
PE3	PE150/2	PE185/2	Oil chamber	Inspection chamber	16.5
	PE185/2	PE200/2	8.0	0.40	
	PE250/2	PE230/2			
	PE110/4	PE300/2			
	PE140/4	PE130/4			
	PE160/4	PE150/4			
	PE185/4	PE185/4			
	PE90/6	PE210/4			
	PE110/6	PE90/6			
	PE140/6	PE110/6			
		PE130/6			
		PE160/6			
		PE120/8			
	PE220/4	PE250/4 PE200/6			
PE300/4 PE185/6 PE220/6	PE250/6 PE350/4				

Volume ratio: 86% oil or water/propylene glycol : 14% air

Specification:

Lubricant PE1 & PE2: white mineral oil VG8 FP153C. Lubricant PE3: hydraulic oil VG46 HLP-D.

Coolant PE3: 70% water/30% glycol

10.7 Bottom plate adjustment (CB & CP)

At manufacture, the bottom plate is fitted to the volute with the correct clearance gap set between the impeller and the bottom plate (for optimum performance max 0.2 mm).

10.7.1 Instructions on how to adjust the bottom plate

To reset the clearance gap following wear:

(**Note:** when adjusting PE3 and CP pumps, steps 1, 2 and 3 do not apply)

1. Check the position of the alignment notch (e) in the fixing lug to determine if the bottom plate is in the factory pre-set position or if the clearance gap has been previously adjusted. If previously adjusted proceed to Step 4.
2. Remove the three screws (c) securing the bottom plate to the volute.
Attention: if, due to corrosion, the bottom plate does not release freely from the volute, DO NOT force it free by tightening the adjusting grub screws (d) against the fixing lugs on the volute as this could damage the lugs on the bottom plate beyond repair! In that case, first remove the volute from the motor housing by releasing the three securing screws (f) and then remove the bottom plate by tapping it free from inside the volute using a mallet and block of wood.
3. Rotate the bottom plate anti-clockwise through 45° from the pre-set position (a) to the secondary alignment position (b) and refit the securing screws.
4. Loosen the adjusting grub screws (d) and tighten the securing screws in the bottom plate evenly until the impeller will lightly, but freely, rub against the bottom plate when rotated by hand.
5. Tighten the grub screws fully to secure the bottom plate in position (max. 33 Nm).

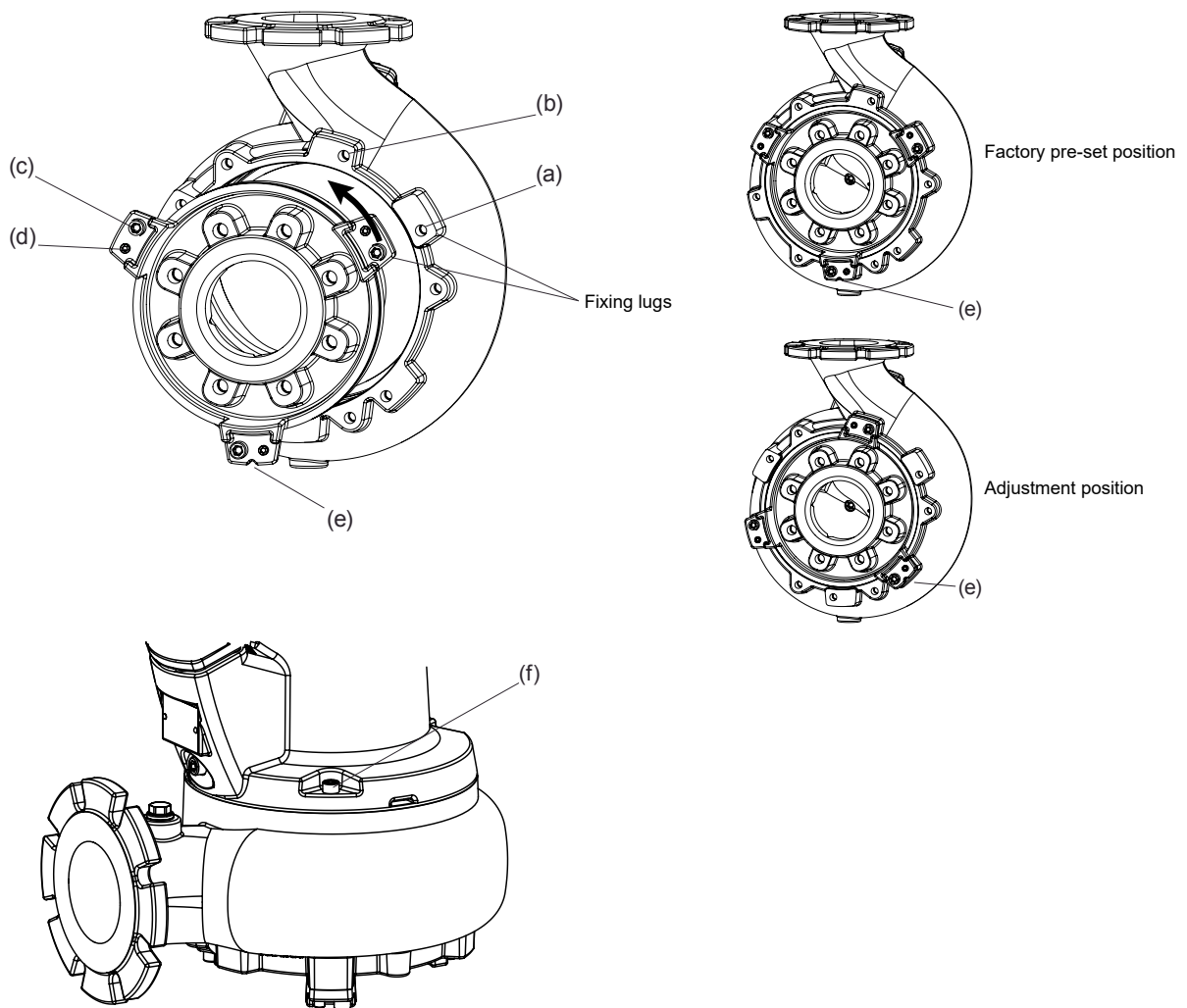

10.8 Bearings and mechanical seals

XFP pumps are fitted with lubricated-for-life ball bearings. The XFP-PE3 upper bearing is a grease-lubricated cylindrical roller bearing.

Shaft sealing is by means of double mechanical seals. XFP-PE3 has an additional inner lipseal at the motor side.

ATTENTION! *Once removed, bearings and seals must not be re-used, and must be replaced in an approved workshop with genuine Sulzer spare parts.*

10.9 Changing the power cable (PE1 & PE2)

To facilitate quick and easy changing or repair of the power cable, the connection between the cable and motor is by means of an integrated 10-pole terminal block.



Before commencing any maintenance work the pump should be completely disconnected from the mains by a qualified person and care should be taken that it cannot be inadvertently switched back on.



To be carried out only by a qualified person, in strict adherence to relevant safety regulations.

10.10 Cleaning

If the pump is used for transportable applications, then in order to avoid deposits of dirt and encrustation it should be cleaned after each usage by pumping clear water. In the case of fixed installation, we recommend that the functioning of the automatic level control system be checked regularly. By switching the selection switch (switch setting "HAND") the sump will be emptied. If deposits of dirt are visible on the floats then these should be cleaned. After cleaning, the pump should be rinsed out with clear water and a number of automatic pumping cycles carried out.

10.11 Venting of the volute

After lowering the pump into a sump full of water, an air lock may occur in the volute and cause pumping problems. To clear the air lock, shake the pump, or raise the pump in the medium and then lower it again. If necessary, repeat this venting procedure.

We strongly recommend that dry-installed XFP pumps are vented back into the sump by means of the drilled and tapped hole provided in the volute.

11 Troubleshooting Guide

Fault	Cause	Fix
Pump does not run	Moisture sensor shutdown.	Check for loose or damaged oil plug, or locate and replace faulty mechanical seal / damaged o-rings. Change oil. ¹⁾
	Air lock in volute	Shake or raise and lower the pump repeatedly until resulting air bubbles no longer appear at surface level.
	Level control override.	Check for float switch that is faulty or tangled and held in OFF position in sump.
	Impeller jammed.	Inspect and remove jammed object. Check gap between impeller and bottom plate and adjust if necessary.
Gate valve closed, non-return valve blocked.		Open gate valve, clean blockage from non-return valve.
Pump switching on/off intermittently	Temperature sensor shutdown.	Motor will restart automatically when pump cools down. Check thermal relay settings in control panel. Check for impeller blockage. If none of above, a service inspection is required. ¹⁾
Low head or flow	Wrong direction of rotation.	Change rotation by interchanging two phases of the power supply cable.
	Gap too wide between impeller and bottom plate	Reduce gap (see page 23).
	Gate valve partially open.	Open valve fully.
Excessive noise or vibration	Defective bearing.	Replace bearing. ¹⁾
	Clogged impeller.	Remove and clean hydraulics.
	Wrong direction of rotation.	Change rotation by interchanging two phases of the power supply cable.



Before commencing any inspection or repair work the pump should be completely disconnected from the mains by a qualified person and care should be taken that it cannot be inadvertently switched back on.

¹⁾Pump must be taken to approved workshop.

SERVICE LOG

Pump Type:

Serial No:

Date

Hours of
Operation

Comments

Sign

SERVICE LOG

Date	Hours of Operation	Comments	Sign

