

TRENCHMAN

heavy duty submersible dewatering pumps with agitator

Trenchman submersible pumps are designed for arduous trench dewatering and site drainage applications. Available in 230/1/50 and 110/1/50 (Auto as standard, Manual on request) they feature highly abrasion resistant Hytrel® coated steel impeller and a SMF5030 sintered agitator.

- Double Mechanical Seal
Upper Ca/Ce - Lower Sic/Sic
- Oil free motor - Auto reset thermal protector
- Materials - Handle: Nylon 6 - Motor Housing/Cover: ADC12 Aluminium Alloy
Pump Casing: FC200 Cast Iron
Strainer: PVC - Shaft: SUS 410
- 10m H07RN-F cable as standard
- Weights: Trenchman 400 = 13.5kg
Trenchman 750 = 16kg
Trenchman 1500 = 20kg

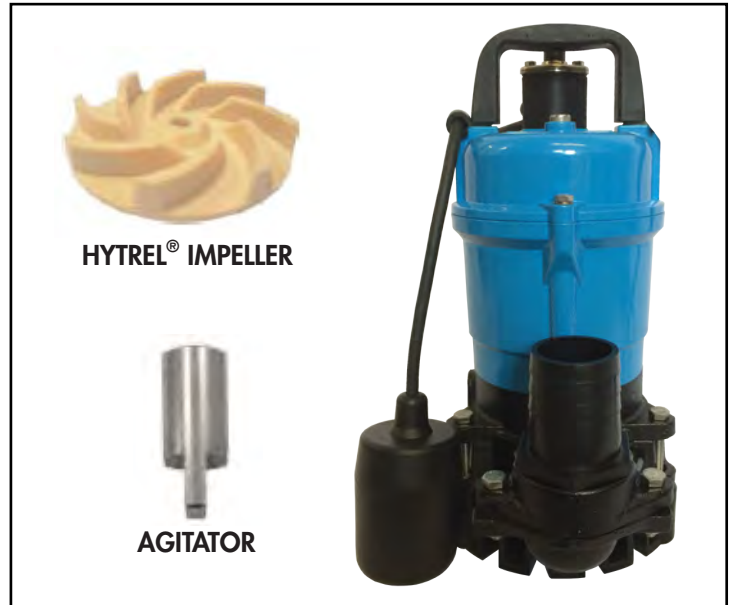

*230V Trenchman 750 & 1500 available with 3" discharge.

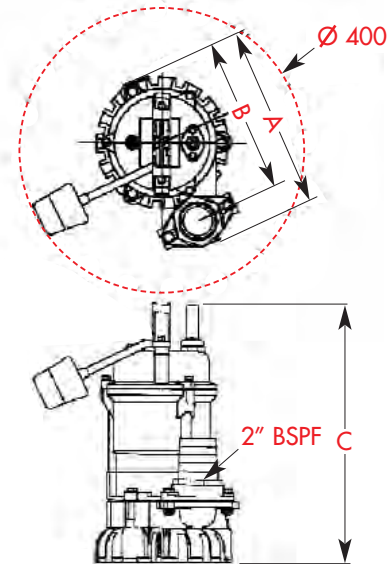
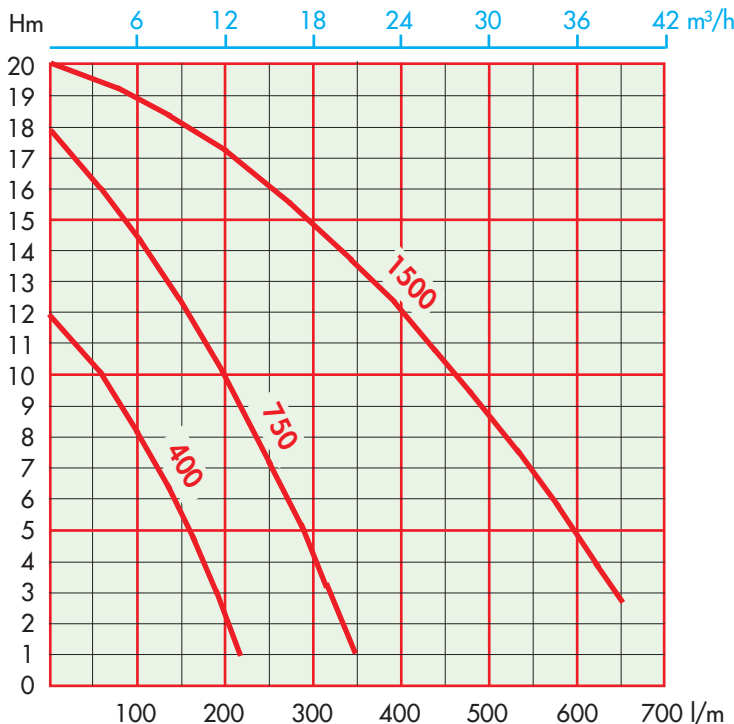

TECHNICAL DATA						
MODEL	NOM kW	NOM Amp		DIMENSIONS mm		
		110V	230V	A	B	C
TRENCHMAN 400A	0.40	6.0	3.0	243	211	352
TRENCHMAN 750A	0.75	11.0	5.4	279	227	377
TRENCHMAN 1500A	1.5	-	12.0	313	262	446

© Descriptions, technical data and features contained in this leaflet are not binding. We reserve the right to make any necessary modifications without prior notice.