

Product Information:

Please read the operating instructions before use, and safe keeping.

TRENCHMAN

Heavy Duty Submersible Dewatering Pumps
with Agitator

Submersible Drainage Pump OPERATION & SERVICE MANUAL



Automated Environmental Systems

Automated Environmental Systems Ltd.,
Unit B, Anglian Lane,
Bury St. Edmunds,
Suffolk, IP32 6SR

01284 658770

sales@automatedenvironmentalsystems.co.uk

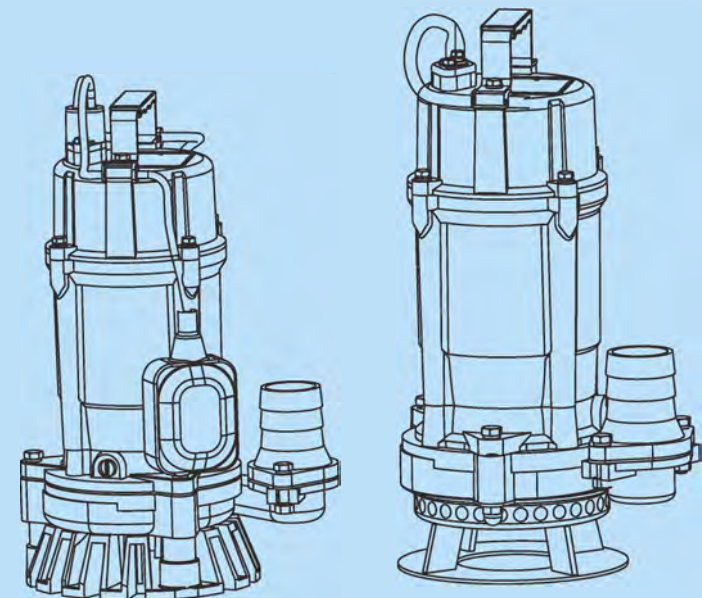

Distributor:

※Because of the continuous progress of technology, our corporation reserves the right to change design and programming without prior notice.

CONTENTS

| | |
|--|----|
| 1.Introduction | 1 |
| (1) Safety terminology and symbols | 1 |
| (2) Product warranty | 2 |
| (3) Safety | 3 |
| (4) User safety | 3 |
| (5) Environmental safety | 4 |
| 2.Product description | 4 |
| (1) Pump design | 4 |
| (2) Intended use | 5 |
| (3) The data plate | 5 |
| (4) Pump part names | 6 |
| 3.Prior to use | 7 |
| (1) Inspect the product | 7 |
| (2) Inspect the specification | 7 |
| (3) Product specification | 7 |
| (4) Method of starting | 7 |
| 4.Installation | 7 |
| (1) Preparation for installation | 8 |
| (2) Install the pump | 9 |
| (3) Make the electrical connections | 11 |
| (4) Grounding | 11 |
| (5) Connecting the cables | 12 |
| 5.Operation | 13 |
| (1) Before operation | 14 |
| (2) Trial operation | 14 |
| (3) Operation | 16 |
| (4) Motor protection system | 17 |
| (5) Water level during operation | 17 |
| 6.Maintenance and inspection | 18 |
| (1) Inspection | 18 |
| (2) Storage | 19 |
| (3) Maintenance | 19 |
| (4) Disassembly and reassembly procedure | 20 |
| 7.Trouble shooting | 23 |

1. Introduction

Purpose of this manual

The purpose of this manual is to provide necessary information for:

- Installation
- Operation
- Maintenance



CAUTION:

Read this manual carefully before installing and using the product. Improper use of the product can cause personal injury and damage to property, and may void the warranty.

NOTICE:

Save this manual for future reference, and keep it readily available at the location of the unit.



(1) Safety terminology and symbols

About safety messages

It is extremely important that you read, understand, and follow the safety messages and regulations carefully before handling the product. They are published to help prevent these hazards:

- Personal accidents and health problems
- Damage to the product
- Product malfunction

Hazard levels

| Hazard level | Indication |
|---|---|
|  DANGER: | <ul style="list-style-type: none">• A hazardous situation which, if not avoided, will result in death or serious injury |
|  WARNING: | <ul style="list-style-type: none">• A hazardous situation which, if not avoided, could result in death or serious injury |
|  CAUTION: | <ul style="list-style-type: none">• A hazardous situation which, if not avoided, could result in minor or moderate injury |
| NOTICE: | <ul style="list-style-type: none">• A potential situation which, if not avoided, could result in undesirable conditions• A practice not related to personal injury |

Hazard categories

- Hazard categories can either fall under hazard levels or let specific symbols replace the ordinary hazard level symbols. Electrical hazards are indicated by the following specific symbol:



Electrical hazard:

These are examples of other categories that can occur. They fall under the ordinary hazard levels and may use complementing symbols:

- Crush hazard
- Cutting hazard
- Arc flash hazard

(2) Product warranty

Coverage

The manufacturer undertakes to remedy the following faults in products sold by the manufacturer under the following conditions:

- The faults are due to defects in design, materials or workmanship.
- The faults are reported to the manufacturer representative within the warranty period.
- The product is used only under the conditions described in this manual.
- The monitoring equipment incorporated in the product is correctly connected and in use.
- All service and repair work is done by personnel authorized by the manufacturer.
- Genuine the manufacturer parts are used.

Limitations

The warranty does not cover faults caused by the following:

- Deficient maintenance
- Improper installation
- Modifications or changes to the product and installation carried out without consulting the manufacturer
- Incorrectly executed repair work
- Normal wear and tear

The manufacturer assumes no liability for the following:

- Bodily injuries
- Material damages
- Economic losses

Warranty claim

The manufacturer products are high-quality products with expected reliable operation and long life. However, should the need arise for a warranty claim; please contact your the manufacturer representative.

Spare parts

The manufacturer guarantees that spare parts will be available for 10 years after the manufacture of this product has been discontinued.

NOTICE:

When purchasing pump parts, please provide product code showed at the nameplate.

(3) Safety



WARNING:

- The operator must be aware of safety precautions to prevent physical injury.
- Any pressure-containing device can explode, rupture, or discharge its contents if it is over-pressurized. Take all necessary measures to avoid over-pressurization.
- Operating, installing, or maintaining the unit in any way that is not covered in this manual could cause death, serious personal injury, or damage to the equipment. This includes any modification to the equipment or use of parts not provided by the manufacturer. If there is a question regarding the intended use of the equipment, please contact the manufacturer representative before proceeding.
- This manual clearly identifies accepted methods for disassembling units. These methods must be adhered to. Trapped liquid can rapidly expand and result in a violent explosion and injury. Never apply heat to impellers, propellers, or their retaining devices to aid in their removal.
- Do not change the service application without the approval of an authorized the manufacturer representative.



CAUTION:

You must observe the instructions contained in this manual. Failure to do so could result in physical injury, damage, or delays.

(4) User safety

General safety rules

These safety rules apply:

- Always keep the work area clean.
- Pay attention to the risks presented by gas and vapors in the work area.
- Avoid all electrical dangers. Pay attention to the risks of electric shock or arc flash hazards.
- Always bear in mind the risk of drowning, electrical accidents, and burn injuries.

NOTICE:

Never operate a unit unless safety devices are installed. Also see specific information about safety devices in other chapters of this manual.

Electrical connections

Electrical connections must be made by certified electricians in compliance with all international, national, state, and local regulations. For more information about requirements, see sections dealing specifically with electrical connections.

Hazardous liquids

The product is designed for use in liquids that can be hazardous to your health. Observe these rules when you work with the product:

- Make sure that all personnel who work with biologically hazardous liquids are vaccinated against diseases to which they may be exposed.
- Observe strict personal cleanliness.

Wash the skin and eyes

Follow these procedures for chemicals or hazardous fluids that have come into contact with your eyes or your skin:

| Condition | Action |
|---------------------------------------|--|
| Chemicals or hazardous fluids in eyes | <ol style="list-style-type: none"> 1. Hold your eyelids apart forcibly with your fingers. 2. Rinse the eyes with eyewash or running water for at least 15 minutes. 3. Seek medical attention. |
| Chemicals or hazardous fluids on skin | <ol style="list-style-type: none"> 1. Remove contaminated clothing. 2. Wash the skin with soap and water for at least 1 minute. 3. Seek medical attention, if necessary. |

(5) Environmental safety

The work area

Always keep the station clean to avoid and/or discover emissions.

Waste and emissions regulations

Observe these safety regulations regarding waste and emissions:

- Dispose appropriately of all waste.
- Handle and dispose of the processed liquid in compliance with applicable environmental regulations.
- Clean up all spills in accordance with safety and environmental procedures.
- Report all environmental emissions to the appropriate authorities.

Electrical installation

For electrical installation recycling requirements, consult your local electric utility.

Recycling guidelines

Always recycle according to the guidelines listed below:

- ① Follow local laws and regulations regarding recycling if the unit or parts are accepted by an authorized recycling company.
- ② If the first guideline is not applicable, then return the unit or parts to the nearest the manufacturer representative.

2. Product description

(1) Pump design

| | | |
|----------------------|---------------------------|---|
| FLUID | TYPE/TEMPERATURE | Work drainage and sand carrying/0 to 40°C |
| PUMP | IMPELLER | Open |
| | SHAFT SEAL | Double mechanical seal |
| | BEARING | Sealed ball bearing |
| MOTOR | TYPE,POLES | Dry type submersible induction motor 2poles |
| | INSULATION | Class F |
| | MOTOR PROTECTOR(BUILT-IN) | Circle thermal protector |
| | LUBRICANT | Turbine oil VG32 |
| DISCHARGE CONNECTION | | Hose coupling |

(2) Intended use

The product is intended for moving waste water, raw and clean water. Always follow the limits given in Application limits (page 9). If there is a question regarding the intended use of the equipment, please contact the manufacturer representative before proceeding.



WARNING:

Only Ex-approved pumps may be used in an explosive or flammable environment.

NOTICE:

Do not use the pump in highly corrosive liquids.

(3) The data plate & The information of pump model

| SUBMERSIBLE PUMP | | | |
|------------------------------|-----------|---------------|-------------------------|
| NO. | (15) | SAP. | (16) |
| MODEL | (1) | | |
| DISCHARGE | (10) mm | HEAD MAX. | (11) m |
| FREQUENCY | (4) Hz | CAPACITY MAX. | (9) m ³ /min |
| PHASE INDUCTION MOTOR OUTPUT | (5) kW | | |
| | (3) V | | (7) A |
| | (6) r/min | ICL | (8) IP 68 |
| T.max. | (12) | | (13) kg |
| | | | (14) m |

| NO. | Legend | NO. | Legend |
|-----|--------------------|-----|-------------------------|
| 1 | Pump model | 9 | Max. capacity |
| 2 | Motor phase number | 10 | Discharge bore |
| 3 | Rated voltage | 11 | Max. total head |
| 4 | Frequency | 12 | Max. liquid temperature |
| 5 | Power | 13 | Weight |
| 6 | Speed | 14 | Max. immersion depth |
| 7 | Rated current | 15 | Serial number |
| 8 | Thermal class | 16 | Product code |

(4) Pump part names

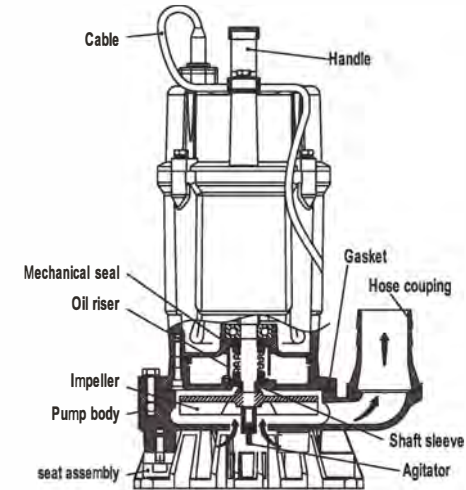

MODEL 1

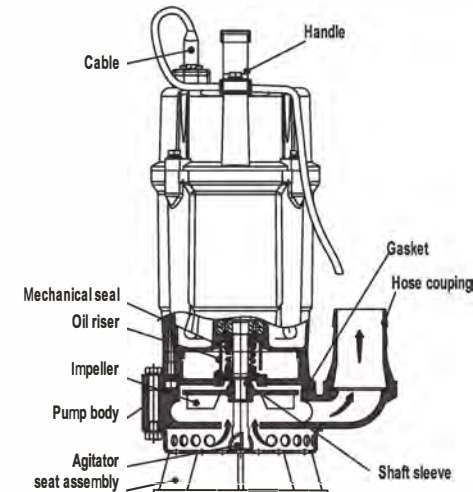

MODEL 2

NOTE: This diagram shows the part layout of a typical model. The external appearance and the internal construction may vary slightly, depending on your particular model.

3. Prior to use

(1) Inspect the product

- ① Inspect the package for damaged or missing items upon delivery.
- ② Unpack the package and verify that no has occurred during shipment and that bolts and nuts have not loosened.
- ③ File a claim with the shipping company if anything is out of order.

NOTICE:

If the product has been picked up at a distributor, make a claim directly to the distributor.

(2) Inspect the specification

Check the nameplate of the pump unit to verify that it is the product that you have ordered. Pay particular attention to its voltage and frequency specifications.

NOTICE:

If you discover any damage or discrepancy, please contact with the manufacturer dealer from whom you purchased the product or the nearest the manufacturer representative office.

(3) Product specification



CAUTION:

Do not use the product under conditions other than those specified. Doing so may lead to short, electrical shock, or fire, or might inhibit the product from attaining its full potential.

(4) Method of starting

Direct-on-line start

4. Installation



DANGER:

Disconnect and lock out electrical power before installing or servicing the unit.



WARNING:

- Do not install the starter equipment in an explosive zone unless it is explosion-proof rated.
- Make sure that the unit can not roll or fall over and injure people or damage property.



WARNING:

Electrical shock hazard. Check that the cable and cable entry have not been damaged during transport before installing the pump.

NOTICE:

Never force piping to make a connection with a pump.

These requirements apply:

- Use the pump dimensional drawing in order to ensure proper installation.
- Provide a suitable barrier around the work area, for example, a guard rail.
- Check the explosion risk before you weld or use electric hand tools.
- Remove all debris from the inlet piping system before you install the pump.
- Always check the impeller rotation before lowering the pump into the pumped liquid.



CAUTION:

- The supply voltage variation:
 - a. continuous running: $\max \pm 5\%$ of the rated voltage.
 - b. intermittent running: $\max \pm 10\%$ of the rated voltage .
- To use the pump, the water temperature should be between 0 °C and 40 °C.
- The pump should be used only for pumping plain water. The pump should not be used to pump fluids such as oil, salt water, or organic solvents.
- The pump must never be used to pump explosive liquids and should not be operated in an area from whom explosive elements might be present.
- The pump must not be used in a partially disassembled state.
- **Do not use the pump in an area where the water pressure exceeds the values given below, as it may damage the pump, or cause a short or electrical shock.**

Maximum immersion depth: 10m

(1) Preparation for installation

Listed below are tools and instruments that are needed to install the submersible pump for general dewatering purpose.



AC voltmeter
(tester)



AC ammeter
(clamp)



Insulation resistance tester
(megger tester)

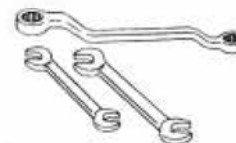

Wrenches for fastening
bolts and nuts



Wrenches for connecting the power supply
(a screwdriver or a box wrench)

Pre-installation check

Measure the resistance between each of the core wires and the ground wire (yellow/green) to verify the insulation resistance of the motor.

NOTICE:

Insulation resistance reference value $\geq 30M\Omega$.

(2) Install the pump

The pump is transportable and intended to operate either completely or partially submerged in the pumped liquid. The pump is equipped with a connection for hose or pipe.

- ① Run the cable so that it has no sharp bends, is not pinched, and can not be sucked into the pump inlet.
- ② Push the hose all the way to the base of the hose coupling. Tighten the hose clamp to secure the hose in place.

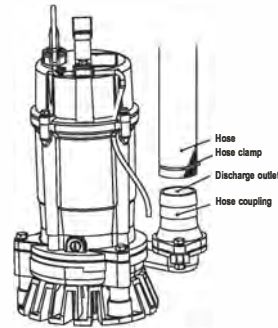

- ③ Handle the pump carefully. When suspending the pump to raise or to lower it, attach a rope to the pump's handle.

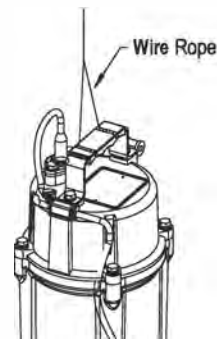

Caution: The rope for suspending the pump during its installation must be of a thickness that accommodates the weight of the pump. When using a chain, make sure that the chain does not become twisted. Failure to observe these precautions could cause the rope or chain to break and the pump to fall and break, which could lead to personal injury.

- ④ Install the pump only in an area that can maintain a proper water level.

NOTE:

For details on the water level necessary for pump operation, refer to the section on "Water Level During Operation" on page 18 of this manual.

- ⑤ The discharge hose can be run vertically or horizontally, but must be without sharp bends.

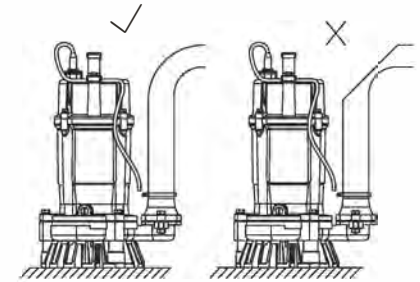

(Pump with soft pipe)

- ⑥ When using a hose to provide piping to the pump, observe the following: Use the shortest possible length of discharge hose and minimize the number of bends. Verify that the end of the hose (discharge side) is lifted above the water surface. If the end of the hose is submerged in water, it may cause the water to flow back when the pump has been stopped. If the end of the hose is located at a level that is lower than that of the source water surface, water may continue to flow out even after the pump has been stopped.

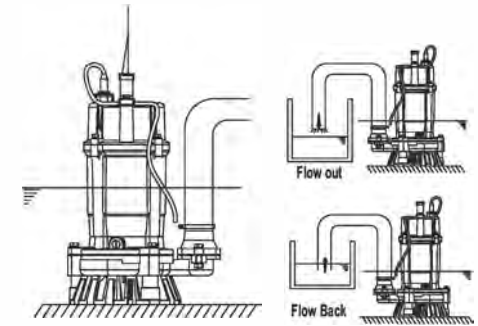

CAUTION:

If an excessive amount of sediment is drawn into the pump, it may cause the pump to wear, which can lead to current leakage or electrical shock.

NOTE:

Appropriate piping materials must be provided by the user. Piping materials are not included with the product.

- ⑦ The pump must be placed upright during operation. If there is a risk that the pump could be buried under the sediment, place the pump on a base made up of materials such as concrete blocks.

(3) Make the electrical connections

General precautions



Electrical hazard:

- A certified electrician must supervise all electrical work. Comply with all local codes and regulations.
- Before starting work on the unit, make sure that the unit and the control panel are isolated from the power supply and can not be energized. This applies to the control circuit as well.
- Leakage into the electrical parts can cause damaged equipment or a blown fuse.
- Keep the end of the motor cable above the liquid level.
- Make sure that all unused conductors are insulated.
- There is a risk of electrical shock or explosion if the electrical connections are not correctly carried out or if there is fault or damage on the product.



WARNING:

Do not install the starter equipment in an explosive zone unless it is explosion proof rated.

Requirements

These general requirements apply for electrical installation:

- The mains voltage and frequency must agree with the specifications on the data plate.
- The fuses and circuit breakers must have the proper rating, and the pump overload protection (motor protection breaker) must be connected and set to the rated current according to the data plate and if applicable the cable chart. The starting current in direct-on-line start can be up to six times higher than the rated current.
- The fuse rating and the cables must be in accordance with the local rules and regulations.
- If intermittent operation is prescribed, then the pump must be provided with monitoring equipment supporting such operation.

(4) Grounding



DANGER:

Disconnect and lock out electrical power before installing or servicing the unit.



WARNING:

- Do not install the starter equipment in an explosive zone unless it is explosion-proof rated.
- Make sure that the unit can not roll or fall over and injure people or damage property.



WARNING:

Electrical shock hazard. Check that the cable and cable entry have not been damaged during transport before installing the pump.

NOTICE:

Never force piping to make a connection with a pump.

(5) Connecting the cables

These are the requirements to follow when you install cables:

- The cables must be in good condition, not have any sharp bends, and not be pinched.
- The sheathing must not be damaged and must not have indentations or be embossed (with markings, etc.) at the cable entry.
- The cable entry seal sleeve and washers must conform to the outside diameter of the cable.
- The minimum bending radius must not be below the accepted value.
- If using a cable which has been used before, a short piece must be peeled off when refitting it so that the cable entry seal sleeve does not close around the cable at the same point again. If the outer sheath of the cable is damaged, then replace the cable. Contact the manufacturer service shop.
- The voltage drop in long cables must be taken into account. The drive unit's rated voltage is the voltage measured at the cable connection point in the pump.



WARNING:

Before connecting the cable to the terminal board, make sure that the power supply (i.e. circuit breaker) is properly disconnected. Failure to do so may lead to electrical shock, short, or injury caused by the unintended starting of the pump.



CAUTION:

- If the cable must be extended, use an extension cable with the same or larger core size as that of the cable that is provided with the pump. Using a cable of proper size will prevent the motor from attaining its full potential or may cause the cable to overheat, which may lead to fire, current leakage, or electrical shock.
- If a cable with a cut or damaged sheath is submerged in water, the water may enter the pump and cause the motor to short. This will damage the pump, which may lead to current leakage, or electrical shock, or burn-out.
- To prevent the cable from cuts or twists, which will damage the pump and may lead to current leakage, electrical shock, or fire, be sure that the tires of vehicles do not run over the cable.
- If the cable must be submerged in water, be sure to mold the connection portion completely. Failure to do so may lead to current leakage, electrical shock, or burn-out.

Never submerge the ends of a cable in water.

If the cable must be extended, use an extension cable with the same or larger core size as that of the cable that is provided with the pump.

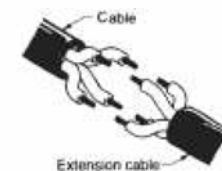

To prevent water from entering inside the cable, be sure to securely mold the cable connection portion.



To avoid damaging the cable, arrange the cable run so that the cable is not bent, kinked, or pressed against a structure.



Tighten the ends of the cable securely against the terminal board.

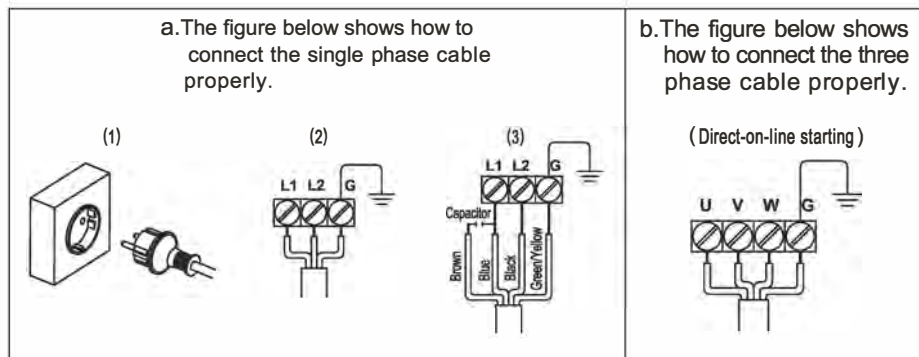

Electric circuit diagrams

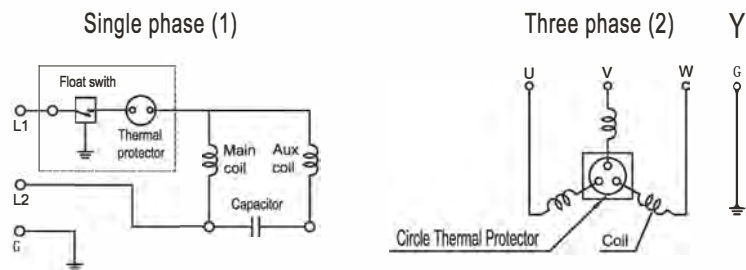

5. Operation

Precautions



DANGER:

If you need to work on the pump, make sure that it is isolated from the power supply and can not be energized.



WARNING:

- Never operate the pump without safety devices installed.
- Never operate the pump with the discharge hose blocked, or the discharge valve closed.
- Make sure you have a clear path of retreat.
- Never work alone.



CAUTION:

If the pump is equipped with automatic level control and/or internal contactor, there is a risk of sudden restart.



NOTE:

- Inspect the pump. Check that there is no physical damage to the pump or cables.
- Check the oil level in the oil housing.
- Remove the fuses or open the circuit breaker, and check that the impeller can be rotated freely.
- Check that the monitoring equipment (if any) works.

Distance to wet areas



Electrical hazard:

- Risk of electrical shock. Make sure no one gets closer than 20 m to the unit when being in contact with the pumped or mixed liquid.
- Risk of electrical shock. This unit has not been investigated for use in swimming pools. If used in connection with swimming pools special safety regulations apply.

(1) Before operation



CAUTION:

- Improper voltage and frequency of the power supply will prevent the pump from attaining its full potential, and may also lead to current leakage, electrical shock, or fire

- ① Once again, check the nameplate of the pump to verify that its voltage and frequency are correct.
- ② Check the wiring, power supply voltage, the capacity of the ground leakage circuit breaker, and the insulation resistance of the motor.

NOTICE:

Insulation resistance reference value $\geq 30M\Omega$. Please refer page 9 for the test method

- ③ Adjust the setting of the overflow protector (i.e. circuit breaker) to the pump's rated current.

NOTICE:

Verify the rated current on the pump's nameplate.

- ④ When using a generator, as much as possible avoid operating the pump in conjunction with other types of equipment.

(2) Trial operation



WARNING:

- Make sure that the unit cannot roll or fall over and injure people or damage property.



WARNING:

- In some installations, the pump and the surrounding liquid may be hot. Bear in mind the risk of burn injuries.
- Make sure nobody is close to the unit when it is started. The unit will jerk in the opposite direction of the impeller rotation.

**CAUTION:**

Make sure to check the pump's direction of rotation when the pump is exposed to atmosphere. Operating the pump in reverse while it is submerged in water will damage the pump, which may lead to current leakage, electrical shock, or fire.

- ① Operate the pump for a short time (1 to 2 seconds), and then check the correct pump rotation.

**WARNING:**

Before changing the connections for reverse rotation, make sure that the power supply (i.e. circuit breaker) is properly disconnected and that the impeller has stopped completely. Failure to observe this may lead to serious accidents, including electrical shock, short, or injury.

- Use a phase rotation indicator to check the correct pump rotation.

NOTICE:

When using a phase rotation indicator, please read the operation manual with it.

Two ways to check the correct pump rotation

- (1) By looking at the impeller; the rotation of the impeller should be counter clockwise as shown in the picture (1) on the right.

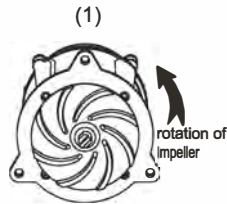

- (2) By looking from the top of the pump. Since the impeller can not be seen, the best way to check the rotation is check the kick back motion of the pump when the pump just starts. The kick back motion of the pump should be counter clockwise as shown in the picture (2) on the right.

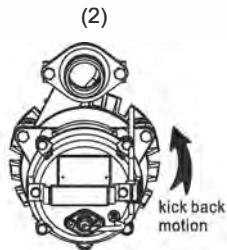

Note: For pump with float switch, you should hand the float to pick up, otherwise the pump can not start

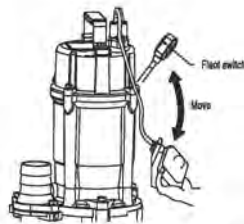

To reverse the rotation about three phase, the following countermeasure must be taken.

COUNTERMEASURE:

Interchange two of the three wires designated U, V, and W, respectively.

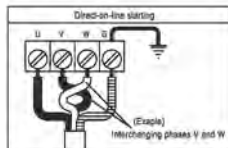

- ② Operate the pump for a short time (≤ 1 minutes) and perform the following checks:

- **Operating current**

Use an AC ammeter (clamp), measure the current at the phase U, V, and W that are connected to the terminal board.

- **Operation voltage**

Use an AC voltmeter (tester) to measure the voltage at the terminal board.

Power supply voltage tolerance = within $\pm 10\%$ of the rated voltage.

- **Vibration**

**CAUTION:**

If the pump generates a considerable amount of vibration, noise, or smell, disconnect the power supply immediately and contact the dealer where you purchased the equipment or the manufacturer sales office in your area.

Continue operations if no abnormal conditions are found during the trial operation.

(3) Operation**WARNING:**

- The pump may be extremely hot during operation. To prevent burns, do not touch the pump with bare hands.
- Do not insert your finger or a stick into the pump's inlet opening. Doing so may cause injury, electrical shock, short, or fire.
- When the pump is not used for a long time, make sure that the power supply (such as a breaker) is properly disconnected. If the wiring insulation deteriorates with the power supply connected, it may cause current leakage, electrical shock, or fire.

**WARNING:**

- During inspection and repair, disconnect the power supply to avoid starting the pump unintentionally. Failure to disconnect the power supply may lead to serious accidents including electrical shock, short, and injury.
- During a power outage, disconnect the power supply to the pump. Unintentional operation of the pump after power resumption would be extremely dangerous to people around the pump.

**CAUTION:**

- Unless the cause of a problem is removed, the pump will repeat the stop-and-go cycle, eventually resulting in damage to the pump, and causing current leakage and electrical shock. Therefore, after verifying that the power supply is disconnected, find and correct the cause of the problem through inspection and repair.
- Do not operate the pump at unusually low head, or when the strainer is clogged with debris. Doing so will prevent the pump from attaining its full potential, and may also generate abnormal noise and vibration and cause damage to the pump, which may lead to current leakage, electrical shock, and fire.

To protect the motor, if a current overload occurs in the motor or if the motor overheats under the conditions given below, the pump will stop automatically, regardless of the water level during operation.

- Extreme fluctuation of power supply voltage.
- Pump operated under overload condition.
- Pump operated at open phase or binding condition.

(4) Motor protection system



WARNING:

Circle thermal protector

The pump is equipped with an internal motor protective device (circle thermal protector).

If an excessive current is detected or the motor overheats, for reasons such as the following, the pump will automatically stop operating regardless of the water level, to protect the motor

- Change in supply voltage polarity
- Overload
- Open-phase operation or operation under constraint

WARNING:

- A b-contact miniature protector is adopted, which is normally "closed" and goes to "open" upon overheating.
- To protect the motor from current surges, be sure to install a motor breaker, thermal relay or similar device in the external starting console or control panel.

(5) Water level during operation

Pay attention to the water level during the pump operation. The pump will become damaged if it is allowed to operate dry.



CAUTION:

- Do not operate the pump below Continuous running Water Level (C.W.L.), as doing so will damage the pump, causing current leakage and electrical shock.

The table below shows the water level during operation by output. Make sure that the water level will not be under these levels.

| MODEL | C.W.L. | |
|---------|--------|--|
| MODEL 1 | 85 | |
| MODEL 2 | 95 | |

The water level for the models which is not included in the tables: as per the picture shown: the lowest water level should submerge the pump strainer

6. Maintenance and inspection

Precautions



DANGER:

Disconnect and lock out electrical power before installing or servicing the unit.



WARNING:

- Always follow safety guidelines when working on the product.
- Make sure that the unit can not roll or fall over and injure people or damage property.
- Rinse the unit thoroughly with clean water before working on the unit.
- Rinse the components in water after dismantling.

Make sure that you follow these requirements:

- Check the explosion risk before you weld or use electrical hand tools.
- Allow all system and pump components to cool before you handle them.
- Make sure that the product and its components have been thoroughly cleaned.
- Do not open any vent or drain valves or remove any plugs while the system is pressurized. Make sure that the pump is isolated from the system and that pressure is relieved before you disassemble the pump, remove plugs, or disconnect piping.

Washing the pump

Remove any debris attached to the pump's outer surface, and wash the pump with tap water. Pay particular attention to the impeller area, and completely remove any debris from the impeller.

Inspecting the pump exterior

Verify that the paint is not peeled, that there is no damage, and that the bolts and nuts have not loosened. If the paint has peeled, allow the pump to dry and apply touch-up paint.

NOTE:

Touch-up paint must be provided by the user. If the pump must be disassembled due to damage or loose bolts or nuts, contact the dealer from whom you purchased the equipment or the manufacturer sales office in your area.

(1) Inspection

| Interval | Inspection item |
|----------|---|
| Monthly | <ul style="list-style-type: none"> • Measuring insulation resistance ■ Cold Insulation resistance reference value $\geq 20M\Omega$min (cold). ■ Thermal Insulation resistance reference value $\geq 1M\Omega$min (thermal). <p>NOTE: The motor must be inspected if the insulation resistance is considerably lower than that obtained during the last inspection.</p> |
| | <ul style="list-style-type: none"> • Measuring the loaded current ■ To be within the rated current |

| Interval | Inspection item |
|-------------------------|---|
| Monthly | <ul style="list-style-type: none"> ● Measuring the power supply voltage ■ Power supply voltage tolerance <ul style="list-style-type: none"> a. continuous running: max±5% of the rated voltage. b. intermittent running: max±10% of the rated voltage . |
| | <ul style="list-style-type: none"> ● Inspecting the impeller ■ If the performance level has decreased considerably, the impeller may be worn. |
| Semi-annually | <ul style="list-style-type: none"> ● Inspection of lifting chain or rope. ● Inspecting and changing oil. |
| Yearly | <ul style="list-style-type: none"> ● Changing the oil and replacing the mechanical seal in the chamber. <p>Every 12 months or after 6,000 hours of use, whichever comes first.</p> <p>NOTE: Contact the dealer from whom you purchased the equipment or the manufacturer sales office in your area to inspect and replace the mechanical seal.</p> |
| Once every 2 to 5 years | <ul style="list-style-type: none"> ● Overhaul ■ The pump must be overhauled even if the pump appears normal during operation. The pump may need to be overhauled earlier if it is used continuously or repeatedly. <p>NOTE: Contact the dealer from whom you purchased the equipment or the manufacturer sales office in your area to overhaul the pump.</p> |

(2)Storage

If the pump will not be operated for a long period of time, pull the pump up, allow it to dry, and store it indoors.

NOTE:

Be sure to perform a trial operation before reinstalling the pump. If the pump remains immersed in water, operate the pump on a regular basis (i.e. once a week) to prevent the impeller from seizing due to rust.

(3) Maintenance

Inspecting oil and Changing oil

Inspecting oil

- Designated oil: Turbine oil VG32.
- Oil volume : Specified volume.

Remove the oil plug and take out a small amount of oil. The oil can be extracted easily by tilting the pump so that the oil plug faces downward. If the oil appears discolored or intermixed with water, a likely cause is a defective shaft sealing device (i.e. mechanical seal), which requires that the pump be disassembled and repaired.

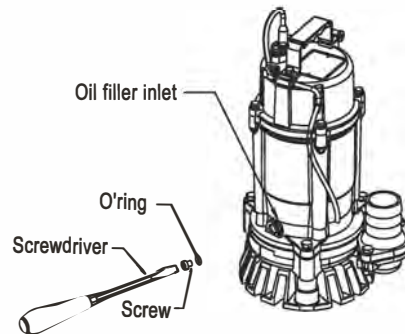

Changing oil

Remove the oil plug and drain the oil completely.
Pour a specified volume of oil into the oil filler inlet.

NOTE:

- The drained oil must be disposed of by waste disposal contractors in compliance with the laws of the located where the pump is being used.
- The gasket and the O-ring for the oil filler plug must be replaced with a new part at each oil inspection and change.

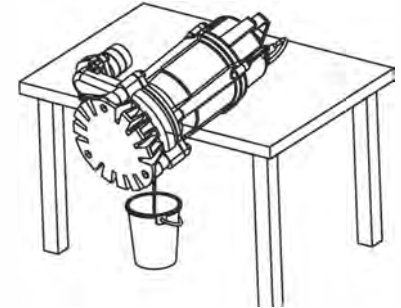

Specified oil volume :180ml

The oil volume for the models which is not included in the tables: about 80% of the total oil cylinder capacity (theoretically, the oil level should cover the mating ring)

The parts listed below are dispensable items. As a rule of thumb, Use the replacement period as a guide to replacing these parts.

| Part name | Replacement condition |
|-------------------|--|
| Gasket and O-ring | Each disassembly or inspection |
| Oil seal | Each disassembly or inspection or if the sealing lip is worn |
| Shaft sleeve | When worn |

(4) Disassembly and reassembly procedure

DANGER:

Disconnect and lock out electrical power before installing or servicing the unit.



WARNING:

A worn impeller and/or pump housing can have very sharp edges. Wear protective gloves.



CAUTION:

Make sure to perform a trial operation when starting the pump after a reassembly. If the pump was assembled improperly, it may lead to abnormal operation, electrical shock, or water damage.

Disassembly Procedure for MODEL 1

NOTE: before disassembling, be sure to drain the oil from the pump.

- (1) Removing the seat assembly and pump body
Remove the bolt from the seat assembly, Remove the bolt and the spring washer from the pump body.
- (2) Removing the impeller
Remove the agitator, the washer from the main shaft then remove the impeller.
- (3) If necessary, remove the seal house and remove the mechanical seal
Remove the key, the washer, the sand guard, the shaft sleeve, the gasket and then remove the seal house, remove the screw from the seal house, at this time, be careful not to damage the sliding surface of the mechanical seal. Remove the mechanical seal from the main shaft.

NOTE:

The Exchange or maintenance of mechanical seal must be handled by the qualified staff.
If you find any omissions, contact the manufacturer sales office in your area.

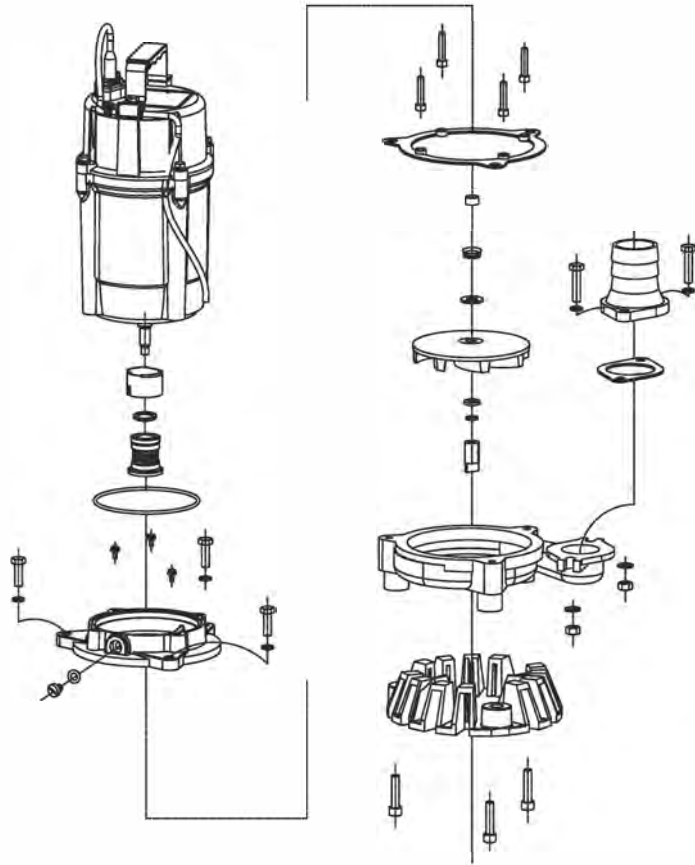

Disassembly Procedure for MODEL 2

NOTE: before disassembling, be sure to drain the oil from the pump.

- (1) Removing the seat assembly and pump body
Remove the nut, the bolt and the washer from the seat assembly and pump body.
- (2) Removing the impeller
Remove the agitator, the washer from the main shaft then remove the impeller.
- (3) If necessary, remove the seal house and remove the mechanical seal
Remove the key, the washer, the sand guard, the shaft sleeve, the gasket and then remove the seal house, remove the screw from the seal house, at this time, be careful not to damage the sliding surface of the mechanical seal. Remove the mechanical seal from the main shaft.

NOTE:

The Exchange or maintenance of mechanical seal must be handled by the qualified staff.
If you find any omissions, contact the manufacturer sales office in your area.

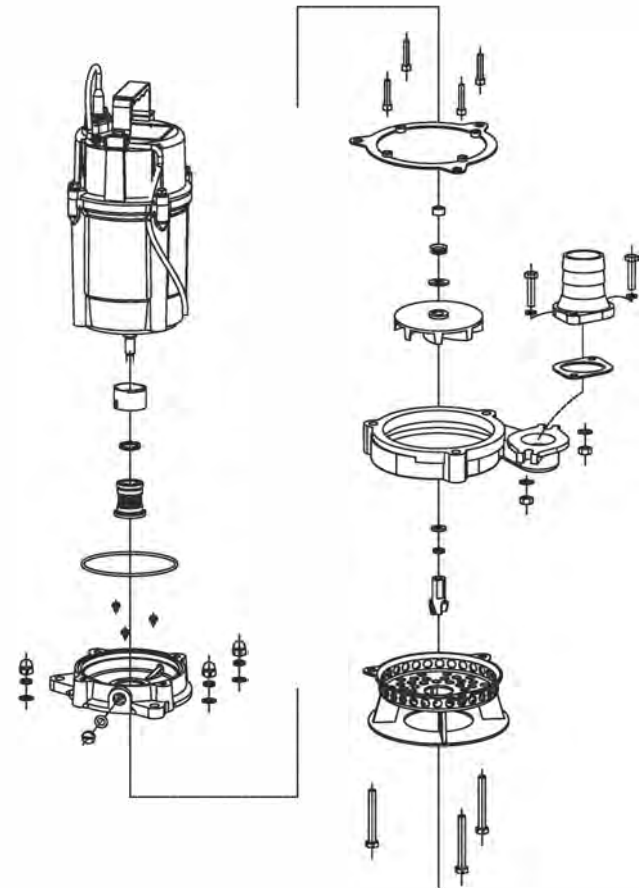

Reassembly procedure

① The reassembly procedure is the reverse sequence of disassembly.

NOTE:

- After completing reassembly, do not forget to pour the specified amount of oil into the pump.
- The gaskets and O-rings must be replaced with new parts. Also replace any parts that are worn or damaged.

② Using a clean rag without oil, wipe the sliding surface of the mechanical seal. Apply oil to the outer circumference of the cushion rubber to facilitate insertion.

NOTE:

For further details on how to install the mechanical seal, refer to the "Mechanical seal handling procedure" that comes with the mechanical seal that is sold separately as a spare part.

③ After installing the impeller, and after completing the reassembly, check that the impeller rotates smoothly and that it does not come in contact with the diffuser.

④ To make sure that the pump operates normally, perform a trial operation before placing the pump back into service.

7. Trouble shooting



DANGER:

Personal injury hazard. Troubleshooting a live control panel exposes personnel to hazardous voltages. Electrical troubleshooting must be done by a qualified electrician. Failure to follow these instructions will result in serious personal injury, death, and/or property damage.



WARNING:

Always disconnect and lock out power before servicing to prevent unexpected startup. Failure to do so could result in death or serious injury.

Read this operation manual carefully before requesting repair. After re-inspecting the pump, if it does not operate normally, contact the dealer from whom you purchased the equipment, or the manufacturer sales office in your area.

| Symptom | Cause | Countermeasure |
|---|--|---|
| Pump fails to start | No power is supplied (i. e. power outage) | Contact the electric power company or an electrical repair shop. |
| | Open circuit or poor connection of the cable. | Check if there is an open circuit in the cable or wiring. |
| | Impeller is obstructed | Inspect the pump and remove the obstruction |
| Pump starts but stops immediately, causing the motor protector to actuate | Impeller is obstructed | Inspect the pump and remove the obstruction. |
| | Voltage drop | Correct the voltage to the rated voltage, or use an extension cable that meets the standard. |
| | Failure round thermal protector or protective device | Replacement or adjustment |
| | A 50 Hz model is operated at 60 Hz. | Check the nameplate and replace the pump or the impeller. |
| | The intake or strainer is obstructed and the pump was operated dry for long hours. | Remove the obstruction. |
| | Motor abnormal. | Repair the motor or replace with a new motor. |
| | The pump is picking up too much sediment. | Place a concrete block under the pump to prevent the pump from picking up sediment. |
| The pump's head and pumping volume is lower. | The impeller is worn. | Replace. |
| | The hose may be kinked or clogged. | Minimize the number of bends in the hose. (In an area with a large amount of debris, use the pump in a meshed basket.) |
| | The submerge depth of pump is too shallow, there is air inhalation | Adjust the submerge depth until the pump is submerged. |
| | Check if the gate valve is open | open gate valve |
| | The intake or strainer is obstructed or buried. | Remove the obstruction. Place a concrete block under the pump to prevent the pump from picking up sediment. |
| The pump generates noise or vibration | The motor rotates in reverse. | Interchange the power supply terminal connection. |
| | The bearing of the motor may be damaged. | To replace the bearing, contact the dealer from whom you purchased the equipment or the manufacturer sales office in your area. |
| | The shaft is bending | correct or contact with the nearest agency of the manufacturer. |