



JS PUMP

# SS Series



# AES

Automated Environmental Systems

01842 819130



## SS Dewatering Pumps

Corrosive water dewatering, chemical sumps, washdown sumps, water remediation

Corrosion resistant 316 stainless steel wastewater/dewatering pumps. All wet parts are made of 316 stainless steel. Elastomers and O-rings are made of FKM. Some models are available in High Head construction. Available with slide rail system to save maintenance cost and time

### Construction Material

- 316 stainless steel construction.
- Double mechanical seals.
- Class F motor insulation.
- Shaft sleeve saves on shaft wear due to abrasives and corrosion.
- Additional lip seal protection keeps impurities and abrasives away from the mechanical seals.
- Thermal overload protection guards against high amperage and high temperature.
- Enhanced cable entry sealing system.

NO.	DESCRIPTION	MATERIAL
01	STRAINER	SUS 304
02	SUCTION COVER	SUS 316
03	NUT	SUS 304
04	WASHER	SUS 304
05	IMPELLER	SUS 316
06	KEY	SUS 304
07	PUMP HOUSING	SUS 316
07-1	ORING	VITON
08	OIL CHAMBER COVER	SUS 316
08-1	ORING	VITON
09	LIP SEAL (BOTTOM)	VITON
11	PLUGS	SUS 316
13	MECHANICAL SEAL	
14	BEARING (BOTTOM)	
16	MOTOR CASING	SUS 316
17	ROTOR SHAFT	SUS 316
18	STATOR	
20	BEARING (UP)	
21A	MOTOR BOTTOM COVER	SUS 316
21A-1	ORING	VITON
23	OVERLOAD PROTECTOR	
26	UPPER COVER	SUS 316
26-1	ORING	VITON
27	CABLE GLAND	SUS 316
27-1	ORING	VITON
31	CABLE	PVC
34	HANDLE	
37	OIL	T-32
38	OUTLET	PP
38F	FLANGE	FC 200
38F-1	GASKET	NBR

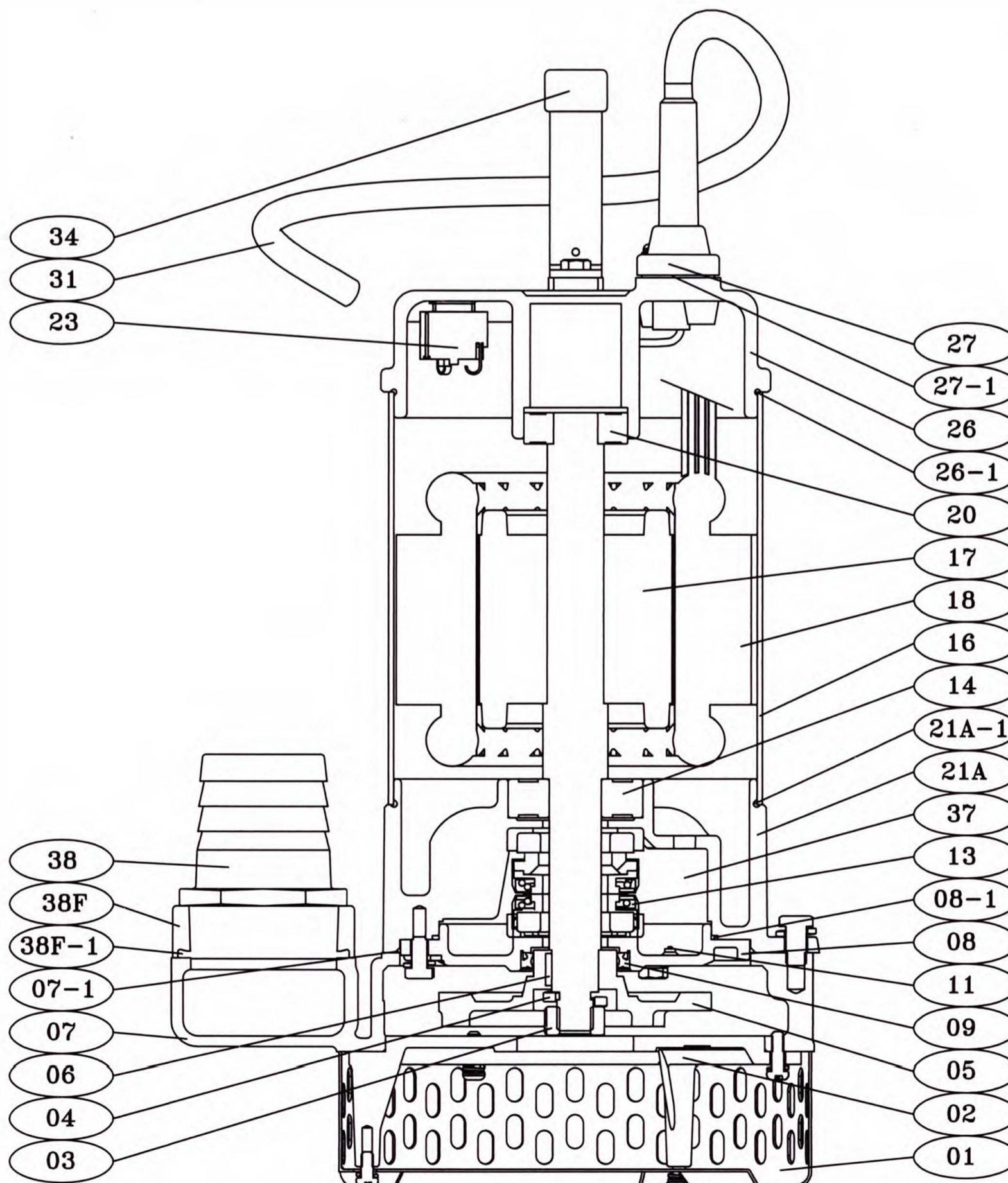

# SS Performance Curve

50/60

Pump Type	Output KW	Output HP	Discharge Inch	Voltage	Max			Cable M	Weight kg
					Head M	Capacity L/min	Solid mm		
JS250SS	0.25	0.34	1½	1 phase 100V-240V	9/8.5	200/180	6	10	9
JS400SS	0.4	0.5	2		11/11.5	250/230	6	10	10
JST750SS	0.75	1	2		15/15	450/400	6	10	24
JS1500SS	1.5	2	3		19/19	680/680	6	10	49
JS1500HSS	1.5	2	2		23/23	560/560	6	10	49
JST8SS	0.75	1	2	3 phase 200V-600V	15/15	450/400	6	10	21
JST15SS	1.5	2	3		19/19	680/680	6	10	26
JST15HSS	1.5	2	2		22/23	560/560	6	10	26
JST22SS	2.2	3	3		20/20	1100/1000	10	10	39
JST22HSS	2.2	3	2		26/29	920/600	10	10	39
JST37SS	3.7	5	3 or 4		24/27	1200/1100	10	10	45
JST37HSS	3.7	5	2		31/32	1000/900	10	10	45
JST55SS	5.5	7.5	4		25/29	1700/1600	10	10	65
JST55HSS	5.5	7.5	3		36/39	1350/1300	10	10	65
JST75SS	7.5	10	6		34/37	2000/2000	10	10	75
JST75HSS	7.5	10	4		40/48	1500/1300	10	10	75
JST110SS	11	15	6		43/43	2300/2300	10	10	85
JST110HSS	11	15	6		60/60	1400/1400	10	10	85
JST150SS	15	20	6		46/45	2750/2650	10	10	167
JST190SS	19	25	6		54/51	2700/2950	10	10	175
JST220SS	22	30	6	60/61	2800/3150	10	10	183	

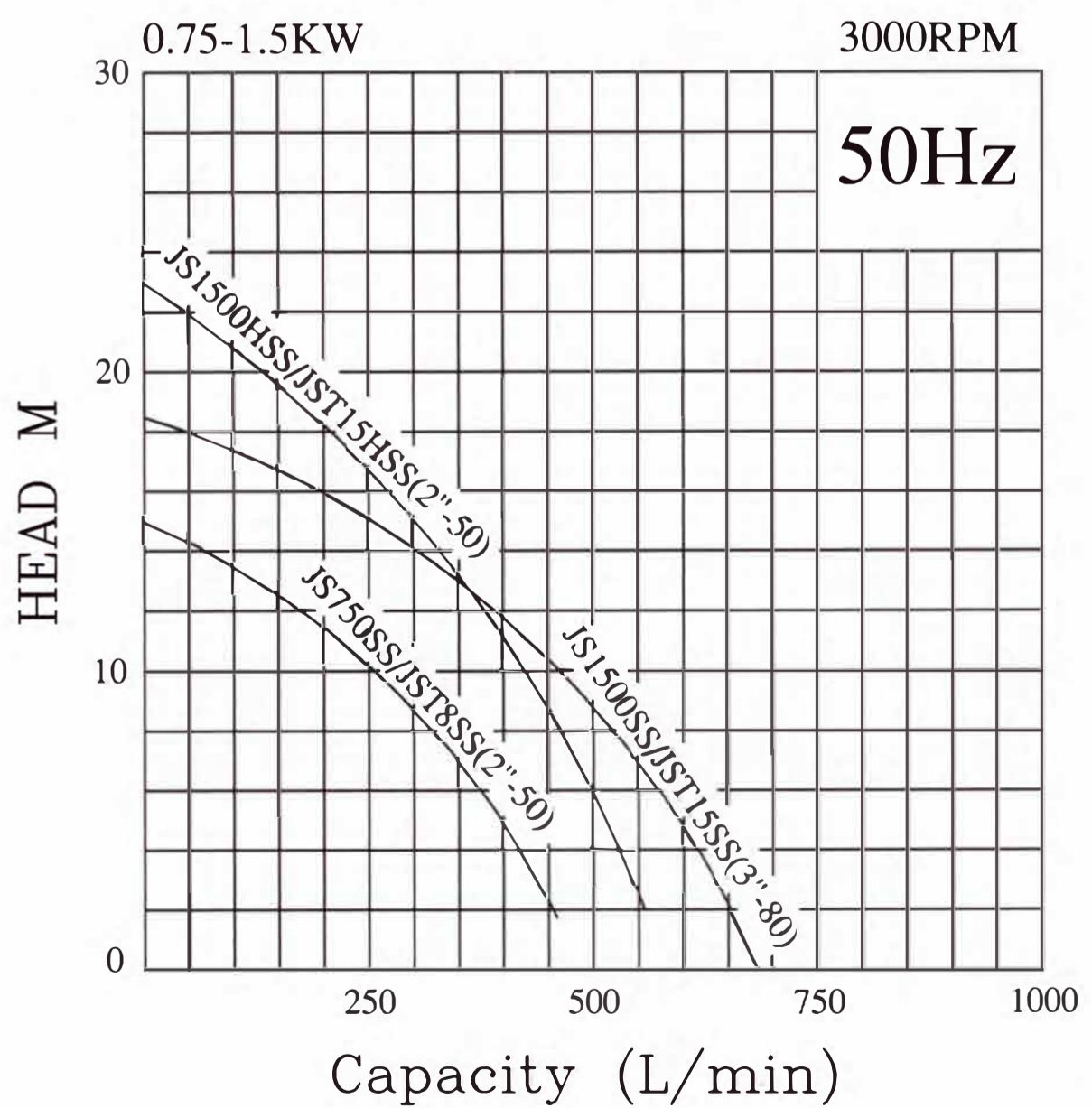
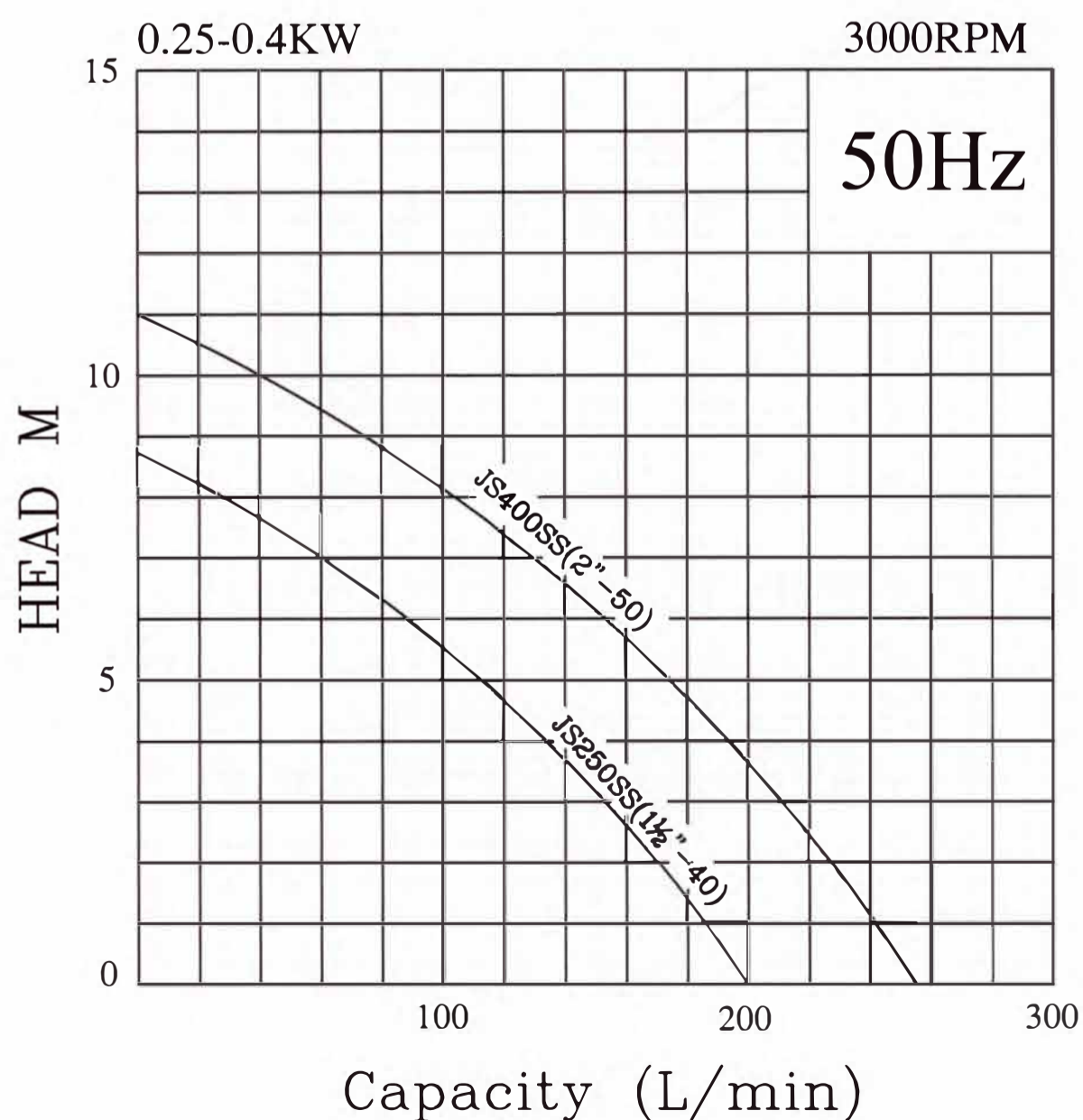

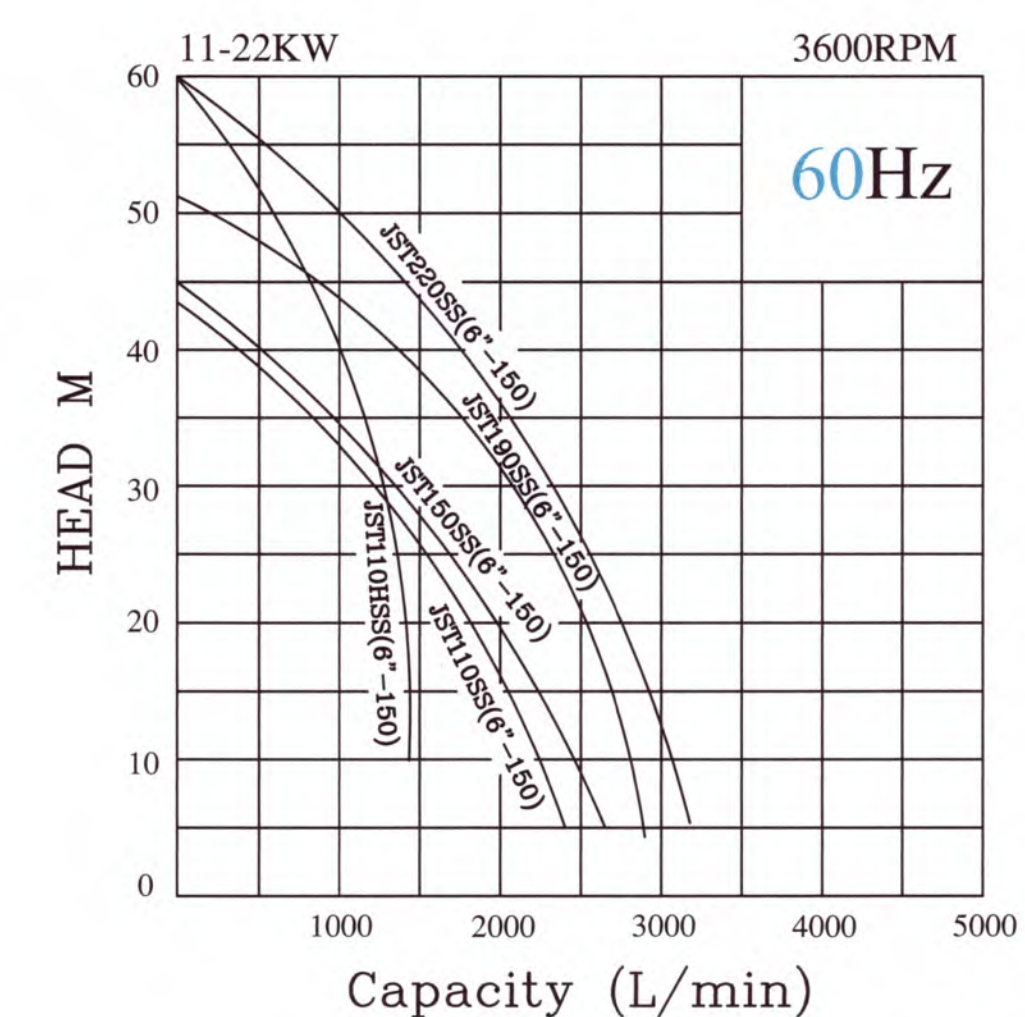
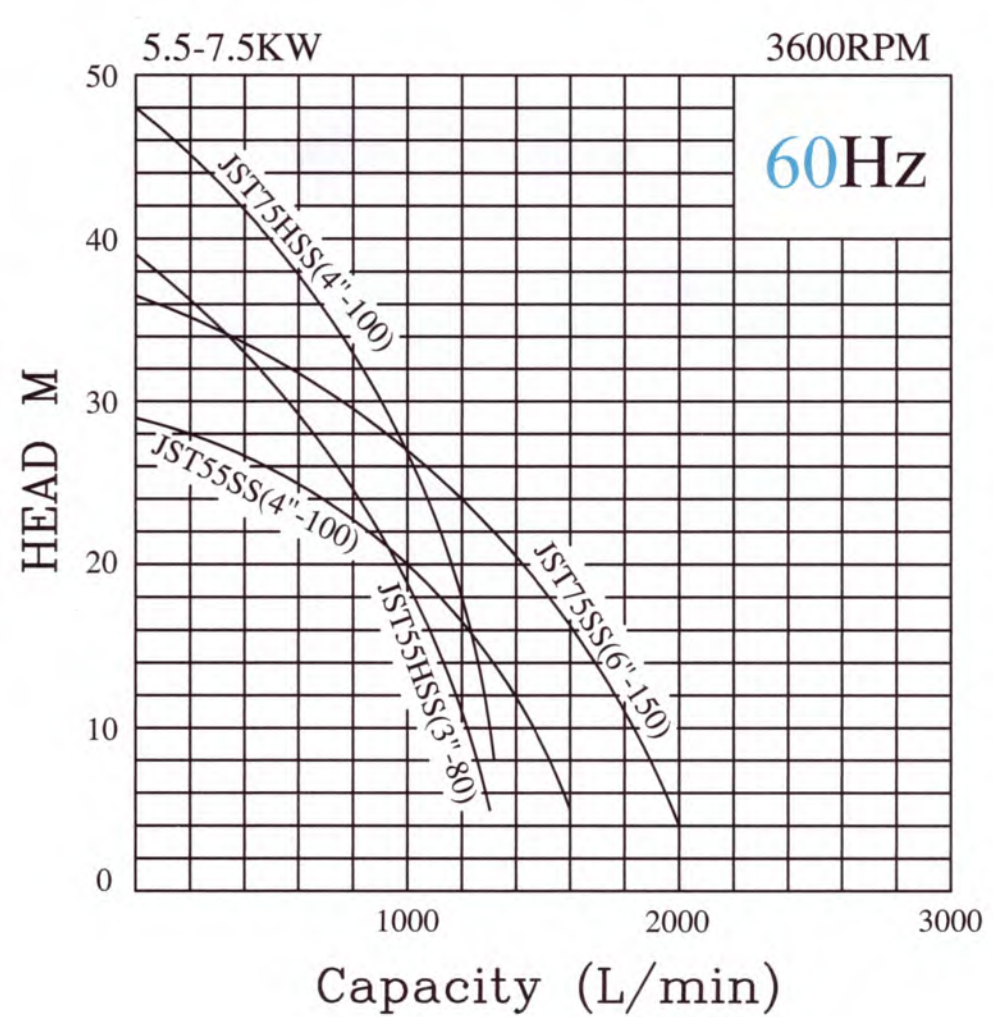
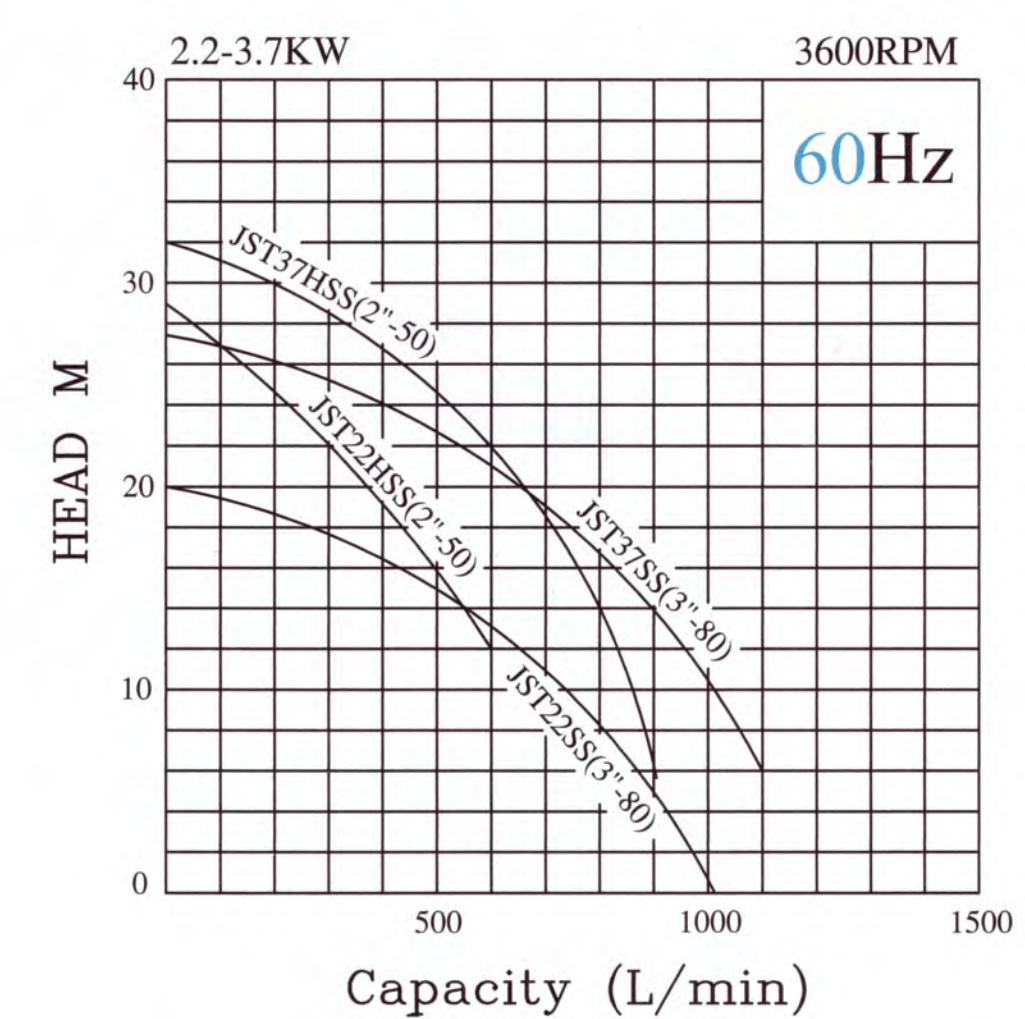
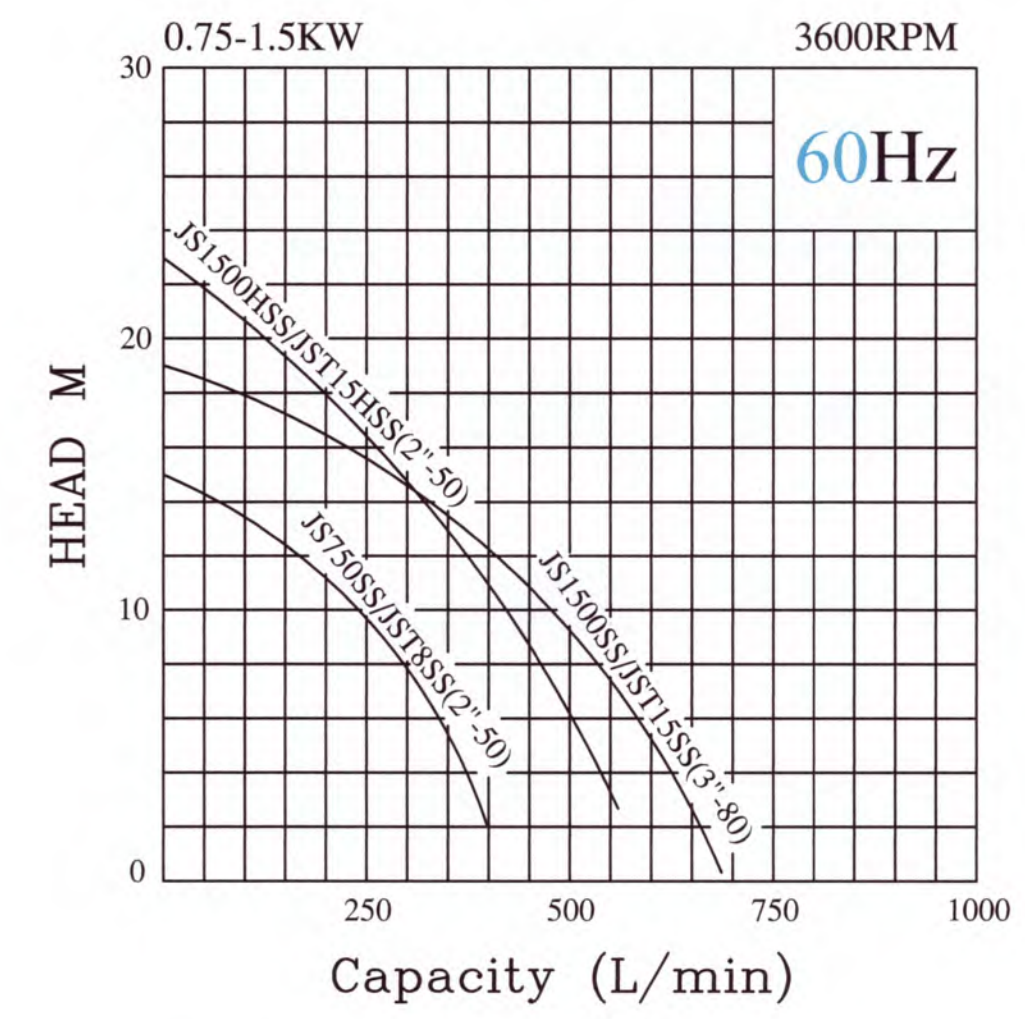
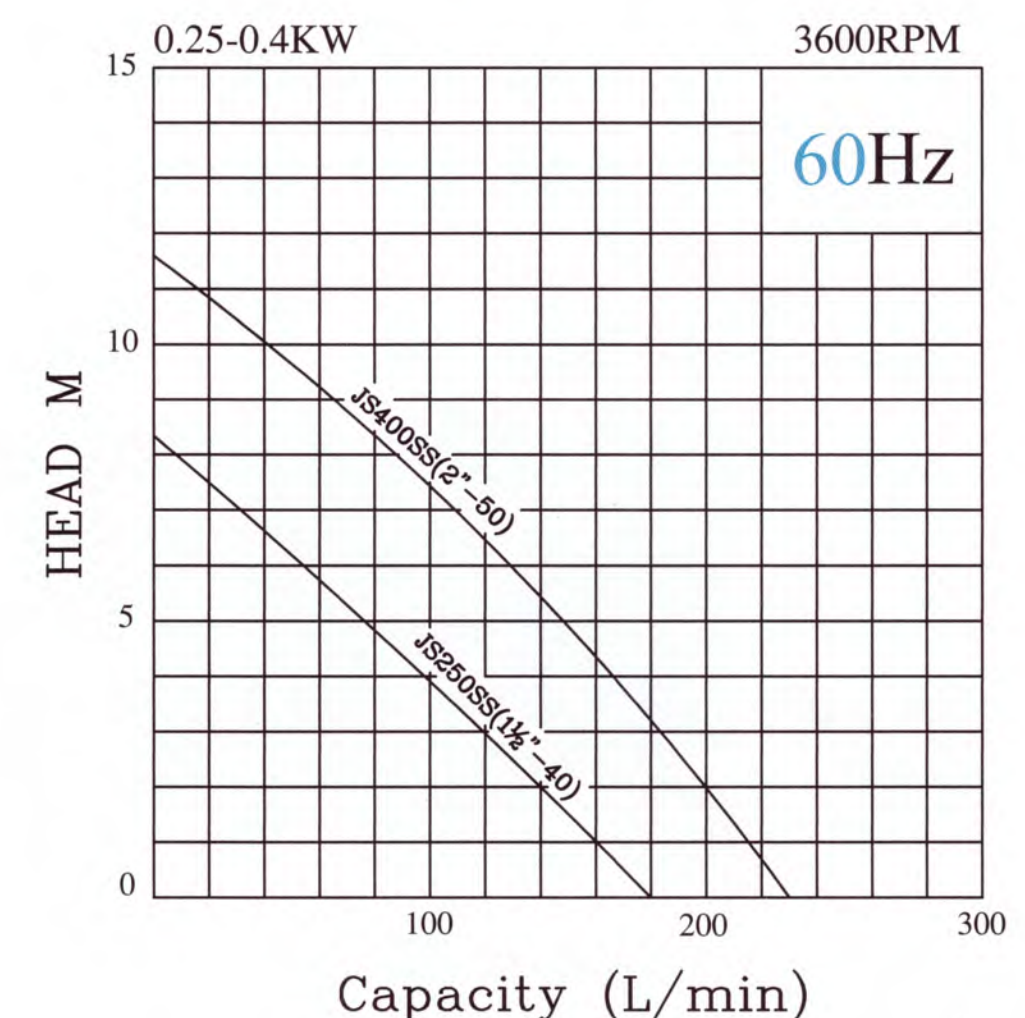
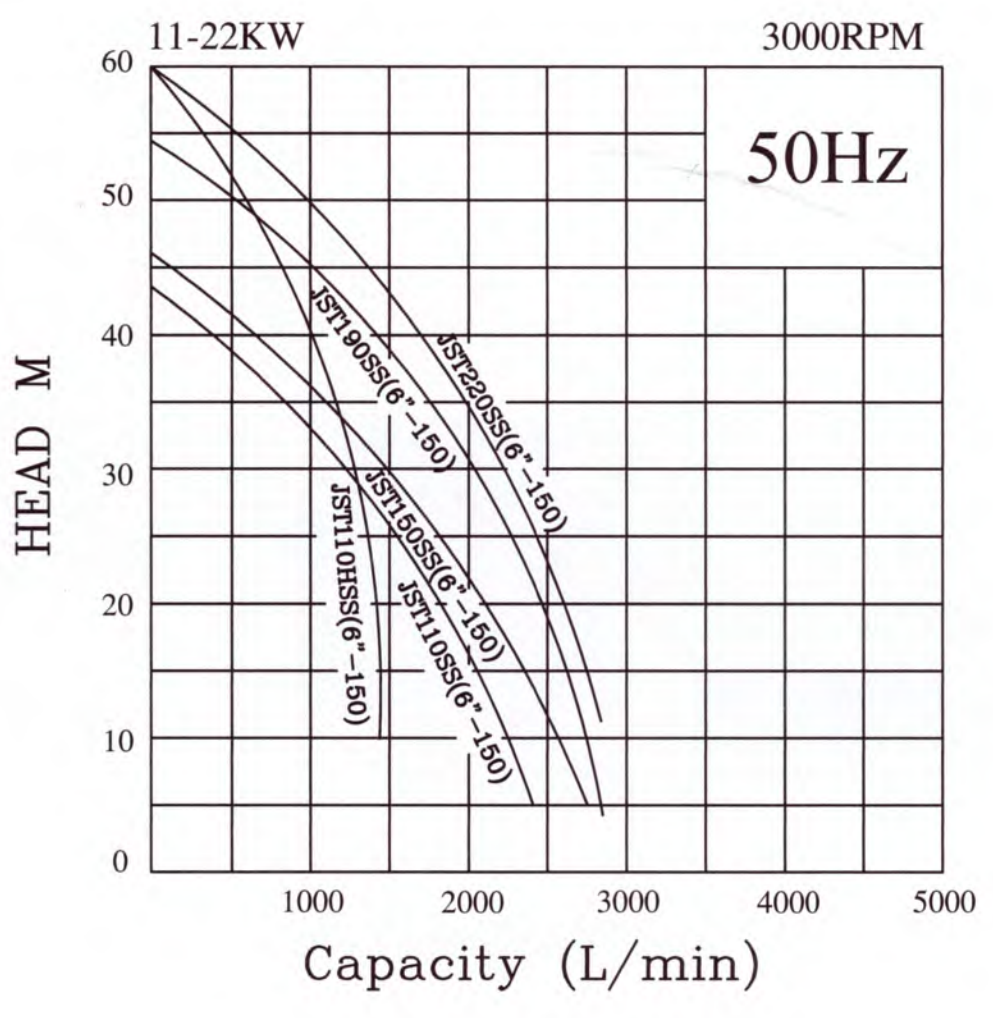
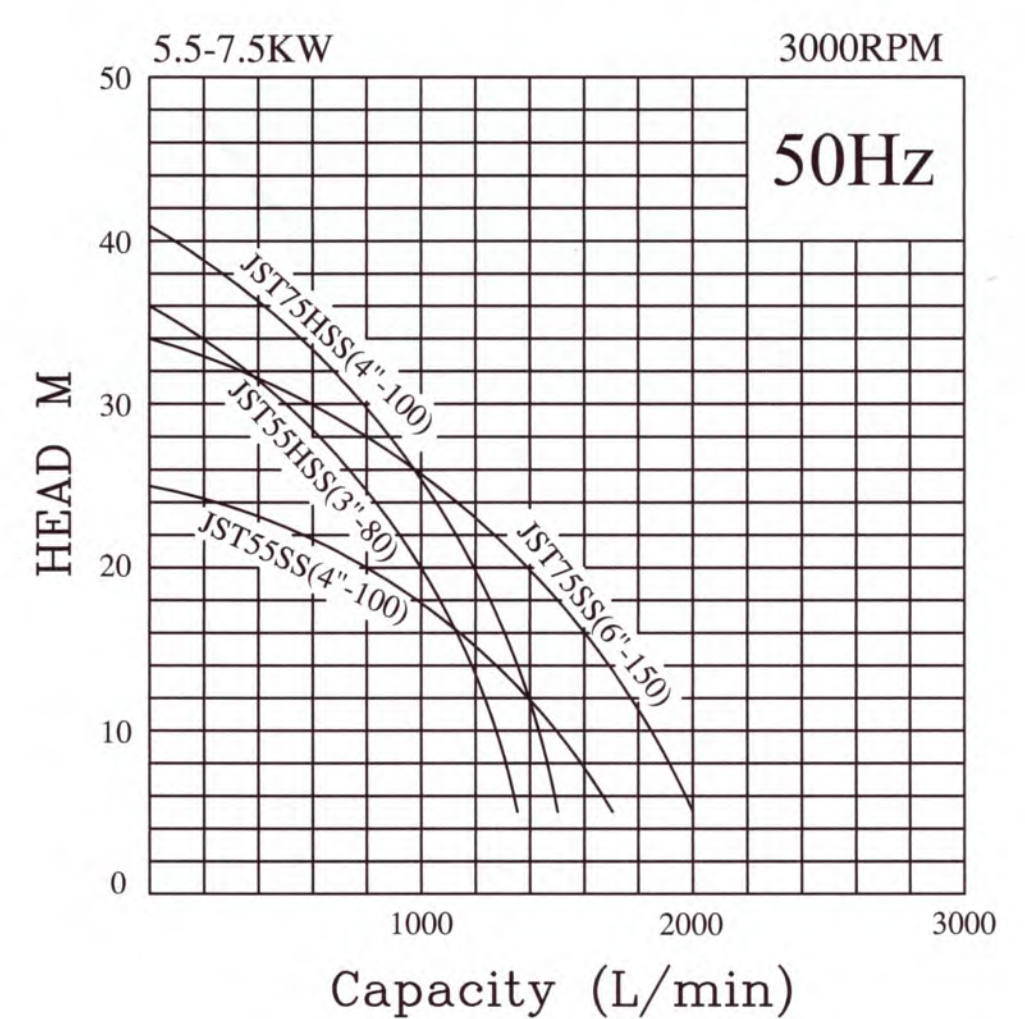
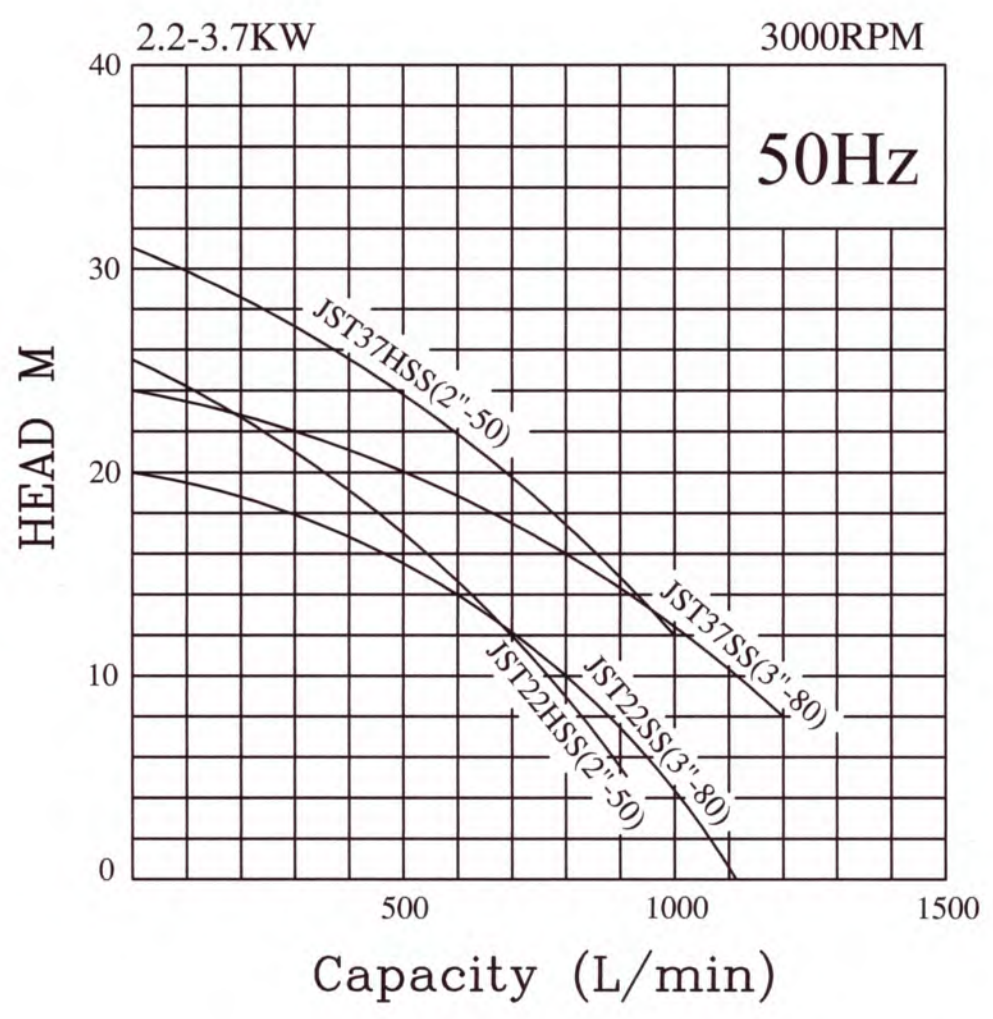

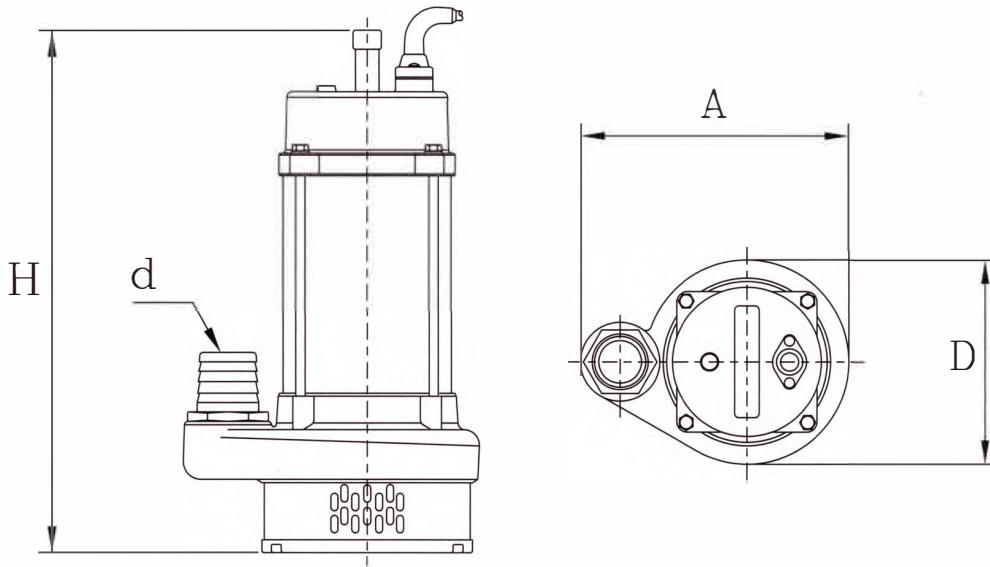

Dimensions

(mm)

PUMP TYPE	DISCHARGE BORE	PUMP SECTION		
	d	A	D	H
JS250SS	1½"(40)	200	148	338
JS400SS	2"(50)	215	148	383
JS750SS	2"(50)	251	190	477
JS1500SS	3"(80)	289	190	512
JS1500HSS	2"(50)	289	190	512
JST8SS	2"(50)	251	190	414
JST15SS	3"(80)	289	190	440
JST15HSS	2"(50)	289	190	440
JST22SS	3"(80)	313	220	503
JST22HSS	2"(50)	313	220	503
JST37SS	3"(80)	313	220	518
JST37SS	4"(100)	313	220	518
JST37HSS	2"(50)	313	220	518
JST55SS	4"(100)	572	270	639
JST55HSS	3"(80)	572	270	639
JST75SS	6"(150)	647	270	692
JST75HSS	4"(100)	572	270	692
JST110SS	6"(150)	647	270	692
JST110HSS	6"(150)	647	270	692
JST150SS	6"(150)	690	310	880
JST190SS	6"(150)	690	310	880
JST220SS	6"(150)	690	310	880