



Packaged Pumping Station

INSTALLATION, OPERATING & MAINTENANCE GUIDELINES

Automated Environmental Systems Ltd.,
Unit B, Anglian Lane,
Bury St. Edmunds,
Suffolk,
IP32 6SR

01284 658770

service@automatedenvironmentalsystems.co.uk

SPECIFIC DETAILS OF THIS INSTALLATION

Customer Name:	
Job/Invoice Number:	
Delivery/Handover Date:	
Tank Type:	
Number of Pumps:	
Pump Make:	
Pump Model:	
Pump Motor Voltage:	
Manhole Cover Rating:	
High Level Alarm Unit:	
Control Panel Model:	

For any queries relating to this equipment, or for the supply of spare parts, servicing and full technical support, please contact:

Automated Environmental Systems Ltd., Unit B, Anglian Lane, Bury St. Edmunds, Suffolk, IP32 6SR

01284 658770 | service@automatedenvironmentalsystems.co.uk

WARNING!

THIS SEWAGE PUMPING STATION IS DESIGNED TO HANDLE EFFLUENT

The following items must be kept out of the pump chamber:

Baby Wipes | Nappies | Cleaning Wipes | Sanitary Towels

THESE TYPES OF PRODUCTS ARE LIKELY TO BLOCK THE PUMPS

**ANY CALLOUT TO UNBLOCK PUMPS WILL BE CHARGEABLE
AND WILL NOT BE COVERED UNDER WARRANTY**

PREFACE

This Operating & Maintenance Manual is divided into various sections, each section providing information for the equipment supplied.

WARNING: THIS IS GIVEN TO DENOTE DANGER TO PERSONNEL WHERE FAILURE TO OBSERVE THESE INSTRUCTIONS COULD RESULT IN INJURY OR DEATH

CAUTION: THIS IS GIVEN WHERE FAILURE TO OBSERVE THESE INSTRUCTIONS COULD RESULT IN DAMAGE TO EQUIPMENT OR POLLUTION OF A SYSTEM BUT NOT A DANGER TO PERSONNEL

IMPORTANT NOTE

The information contained within this manual is intended for use by personnel suitably trained and qualified in the technologies applied to the equipment supplied.

Whilst every care has been taken during the compilation of this manual to ensure that the information provided is correct, no liability can be accepted by Automated Environmental Systems Ltd., or any of its employees for loss, damage or injury caused by any errors in, or omissions from, the information given.

HEALTH & SAFETY: IT IS ESSENTIAL THAT ONLY THOSE WHO ARE QUALIFIED AND AUTHORISED TO DO SO ARE ALLOWED TO WORK ON THIS EQUIPMENT

WARNING: PERSONNEL SHOULD ALWAYS ENSURE THAT ADEQUATE ELECTRICAL AND MECHANICAL ISOLATIONS ARE APPLIED WHEN WORKING ON PLANT EQUIPMENT. IT SHOULD BE NOTED THAT THE PLANT EQUIPMENT CAN START AUTOMATICALLY WITHOUT WARNING

HEALTH & SAFETY

(United Kingdom Health & Safety at Work Act 1974)

Section 6 (a) of this Act requires manufacturers to advise their customers on the safety and serving of their products.

The user's attention is therefore drawn to the following:

1. The appropriate sections of this manual must be read before working on the equipment
2. Installation, operation and maintenance must only be carried out by suitably trained / qualified personnel
3. Normal safety precautions must be taken and appropriate procedures observed to avoid accidents

Note: It is the responsibility of the customer and/or the contractor to ensure that anyone working on the equipment is using all necessary personal protective equipment, is aware of appropriate health & safety warnings and has read the information contained in this section of the manual.

Checklist: In addition to any safety instructions in the various equipment sections of this manual, it is also essential that all persons involved in the operation and maintenance of the pump station are made aware of the dangers associated with the entry of a pump station and take the necessary safety precautions.

ONLY qualified personnel with current Confined Space Entry certification should enter a pump chamber, and then only if there is a second qualified person equipped with required safety equipment supervising.

The following checklist, although not comprehensive, must be followed:

- Conduct a risk assessment before entering the chamber, and fill out associated form
- Do not enter pump station unless absolutely necessary
- Never work alone, use lifting harness, safety line and respirator
- Do not ignore the risk of drowning
- Beware, rungs can give way without warning
- Check that lifting equipment is of an approved type and is in good and safe condition
- Do not ignore the risk of electric shock, use only equipment protected by an RCD
- Isolate power at the control panel before entering the chamber
- Place a suitable barrier around the work zone that meets local rules for safety at work
- Make sure there is a clear path of retreat from the point of installation
- Use all the necessary personal safety equipment such as helmet, safety goggles, rubber gloves and protective footwear
- Do not ignore the risk of infection
- The highest standards of personal hygiene and all local regulations should be observed
- When removing a pump from the chamber, make sure that power is isolated and it cannot be accidentally turned on
- Clean equipment thoroughly before starting to work on it

SAFETY PRECAUTIONS

Before installation, operation or maintenance of the pump system, please read these instructions and the manufacturer's specific equipment instructions carefully.

System operation may cause injury. Take all necessary precautions. Wear necessary protective equipment. Any maintenance of this pump systems must be carried out by authorised and qualified personnel only.

WARNING - PUMP MAY START AT ANY TIME

In normal automatic mode, pumps may start automatically at any time, before maintenance or any work is carried out on pumps or motors, ensure proper isolation of motors at the relevant controller.

WARNING - SYSTEM IS PRESSURISED

Under normal operating conditions, the pipes, pumps and components or water supply and pressure systems are pressurised.

Before unbolting or dismantling any pipework or equipment, ensure that the water supply to the areas of maintenance are isolated and water pressure is relieved.

DANGER - HIGH VOLTAGE

Control boxes contain high voltage, live wiring and terminals.

Entry of control boxes is not permitted except by qualified electrical personnel only, ensure controller is correctly isolated before entering.

CAUTION - EXPOSED MOVING PARTS

Keep clear of all moving parts on pumps, motors and couplings and keep the area around pump system clear at all times.

WARNING - CONFINED SPACE

Pump pit should not be entered by persons, systems are designed to facilitate pump removal and component servicing from the surface.

In the case of entry being unavoidable, the correct safety procedures should be carried out in accordance with current OH&S requirements.

Personnel entering should be certified for confined space entry, have completed risk assessment, evacuated chamber of dangerous gases and be wearing breathing apparatus and safety lifting lanyard/body harness attached to an approved lifting system.

WARNING - NOXIOUS AND DANGEROUS GASES

System may emit dangerous gases, ensure area is well ventilated prior to removing pit cover/lid.

PUMP CHAMBER INSTALLATION GUIDELINES

(United Kingdom Health & Safety at Work Act 1974)

DO NOT BEGIN INSTALLATION OF THIS CHAMBER UNTIL YOU HAVE READ AND FULLY UNDERSTOOD THE REQUIREMENTS BELOW.

THE CONCRETE BACKFILL SHOULD BE DESIGNED TO PROTECT THE CHAMBER FROM ALL EXTERNAL GROUND AND GROUND WATER PRESSURE. THEREFORE IT SHOULD BE WATERTIGHT.

ANY GROUNDWATER ALLOWED TO LEAK BETWEEN THE CONCRETE BACKFILL AND THE PUMP CHAMBER IS LIKELY TO CAUSE A BUILD UP OF PRESSURE WHICH WILL DAMAGE THE CHAMBER.

WE CANNOT ACCEPT RESPONSIBILITY FOR DAMAGE OR DEFORMATION OF THE CHAMBER OR PIPEWORK CAUSED BY EXTERNAL GROUND, GROUNDWATER PRESSURE OR GROUND MOVEMENT DURING OR AFTER INSTALLATION.

DO NOT COMMENCE WITH INSTALLATION IF YOU CANNOT CONTROL ANY GROUNDWATER PRESENT IN ORDER TO PROVIDE A DRY EXCAVATION.

IF NECESSARY LINE THE ENTIRE EXCAVATION WITH A CONTINUOUS LAYER OF PLASTIC SHEETING PRIOR TO INSTALLATION.

As with all site work the dangers of working with water and electricity pose severe threats to health if obvious and fundamental precautions are not taken. Therefore if you are in any doubt to any of the following, please do not hesitate to contact us.

All site work should be undertaken by qualified personnel only.

Lifting & Storage

Tank delivery is direct to site, you will need to offload the tank. This should be carried out by either the main contractor or by a specialist sub-contractor.

Great care should be taken when lifting and handling the chamber and suitable equipment should be used at all times.

The nature of the design means the centre of gravity of the chamber is likely to be offset.

The chambers are best lifted by crane using webbing lifting straps. Any 'lifting eyes' provided on the chamber are untested and should not be used as the sole lifting point for the chamber.

Any storage site should be free of any object which may cause damage to the chamber, and the chamber should be secured to prevent any rolling.

WE CANNOT ACCEPT RESPONSIBILITY FOR ONSITE DAMAGE

Pre-Installation Inspection

Before installation an inspection of the chamber must be carried out to ensure no damage has occurred since delivery and to check all inlet and outlet connections are correct.

Any changes or repairs cannot be made once installation has begun.

Tank Installation

- Select a suitable location for the tank. This will be normally at ground level lower than the properties being drained and allow for the falls in site drainage
- Check that no other structure or special access is required over the selected spot. Provision can always be made, if necessary, to place the tank in a roadway, provided that a suitable protective backfill is placed around it and a suitable heavy-duty manhole cover is used over the opening
- Check that no underground cable, pipe or service duct, lies underneath
- Excavate the minimum opening in the ground to receive the pump chamber and pipework to be used. The depth of excavation needs to be at most, 500mm deeper than the overall tank depth, the sides of the excavation should be shored up for stability. A sump should be left in one corner for dewatering purposes
- A dewatering pump **MUST** be used in the sump to remove any ground water present and provide a dry excavation until the concrete backfill is set, these can be found on our website www.automatedenvironmentalsystems.co.uk
- Some clean hardcore should be placed and consolidated in the base of the excavation. Usually this will need to be around 200mm thick, but in good ground, should be a minimum of 50mm
- In order to be protected from any external force the chamber should be completely surrounded by concrete. The concrete surrounding the chamber should be of suitable thickness, usually a minimum of 150mm, and quality to protect the chamber from all external pressure. Whether this is ground pressure, groundwater pressure, trafficked areas or any other force which may cause damage or deformation to the chamber. **Therefore a qualified civil/structural engineer MUST be consulted to specify the correct concrete backfill suitable for your specific site requirements**
- Pour the appropriate amount of concrete on top of the hardcore, minimum thickness 200mm of CP 20Kn/mm² strength, and then lower the chamber onto the damp concrete allowing the flanged base joint, if fitted, to settle in, ensuring that the inlet and outlet pipes are correctly aligned
- **Note:** In certain circumstances the guiderails can be supplied loose for transport (e.g. when turret extensions are shipped detached). You must ensure that the guide rail poles are fitted to the guide rail duck foot at the bottom of the tank and attached to the upper guide rail bracket at the top of the access turret before concreting the tank into the ground
- Fill the chamber with clean water to depth of approx 500mm and recheck levels. Do not overfill as the chamber is not designed to hold water when not supported by the concrete backfill
- Carefully commence pouring of the concrete backfill evenly around the chamber, maximum 1000mm, ensuring there are no voids which may allow ground water to penetrate. Vibrating pokers should be used with care to avoid damage to the chamber. Allow 24 hours for the concrete to harden

- Continue filling the chamber with clean water whilst evenly backfilling in stages, maximum 1000mm each stage, ensuring the water level is 50mm below the level of the concrete backfill, repeating process until the concrete is approximately 300mm from the top of the chamber
- Connect up the site pipework to the inlet and outlet of the pumpwell, and draw the pump and float cables through the conduit to the control panel before they are encased in concrete
- Under no circumstances should concrete be poured directly onto the chamber. Attempting to pour too much concrete at once will result in the chamber 'floating' or particularly above the halfway point damage to the chamber due to excessive weight on the chamber body for which the manufacturers will not be responsible
- Finish off the surface of the concrete at the required level, depending on the final ground cover required i.e. topsoil, tarmac, gravel etc. (see sketch below). If the access cover or the surrounding area is likely to be subject to other than purely pedestrian traffic, provision must be made to ensure that no weight loading is taken by the chamber i.e. by the construction of a cover slab, and the appropriately specified access cover must be used.

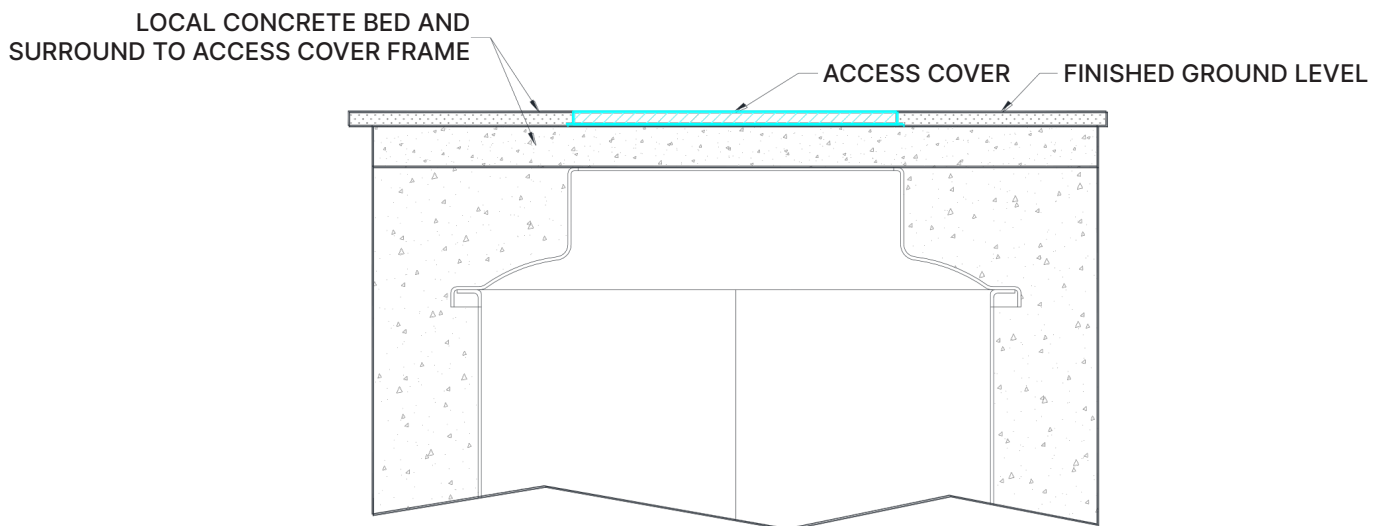

**PLEASE ALLOW THE CONCRETE BACKFILL TO SET BEFORE PUMPING
THE WATER FROM THE PUMP CHAMBER**

ADDITIONAL INSTALLATION NOTES

- A cable duct is required with no sharp bends, minimum size 100mm (ID)
- Tank water should never exceed by more than 300mm past the backfill concrete level
- The inlet(s) and cable duct(s) are to be cut on site to your own specifications, and should be properly sealed with rubber grommets
- It is most important that once the tank is in situ with all the inlet connections made, the drainage system should be flushed out, and all sand, debris etc. removed from the chamber
- If vehicular traffic will be passing over the chamber, it is ESSENTIAL that the cover slab is constructed so that there is NO DIRECT LOAD on the chamber, an access cover with the correct specified S.M.W.L. must be used

WE RECOMMEND THAT ONCE THE SYSTEM HAS BEEN COMPLETELY INSTALLED, OUR ENGINEER ATTENDS THE SITE TO COMMISSION THE SYSTEM

By beginning installation of the unit the installer is deemed to have read and complied with the above. Failure to do so will invalidate your warranty. If you have any questions please contact us.

GUIDE RAIL INSTALLATION GUIDELINES

The following diagrams are a guideline for the installation of the guide rails, fitting may be required where guide rails arrive loose in the chamber or when they are supplied separately, for instance on projects where a separate turret is to be installed.

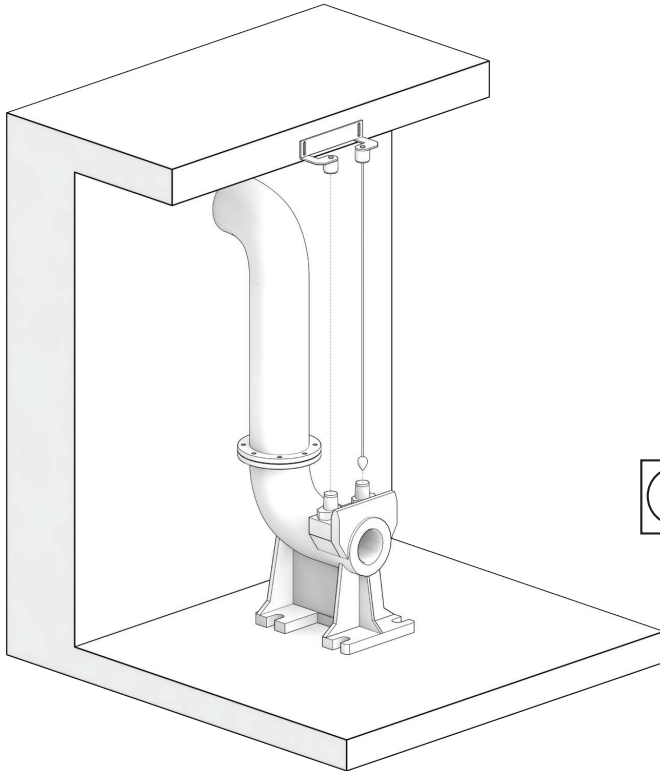

A Remove the upper bracket from top of turret.

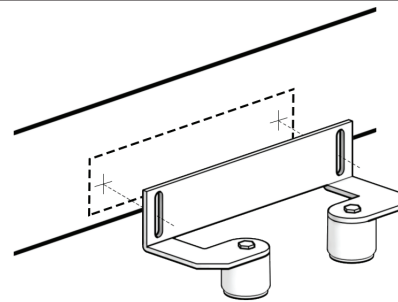

B Slot the rails onto the the guide(s) on the upper bracket.

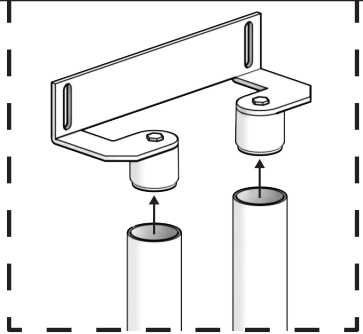

C Then position the other end of the rails down onto the guide(s) of the lower pedestal.

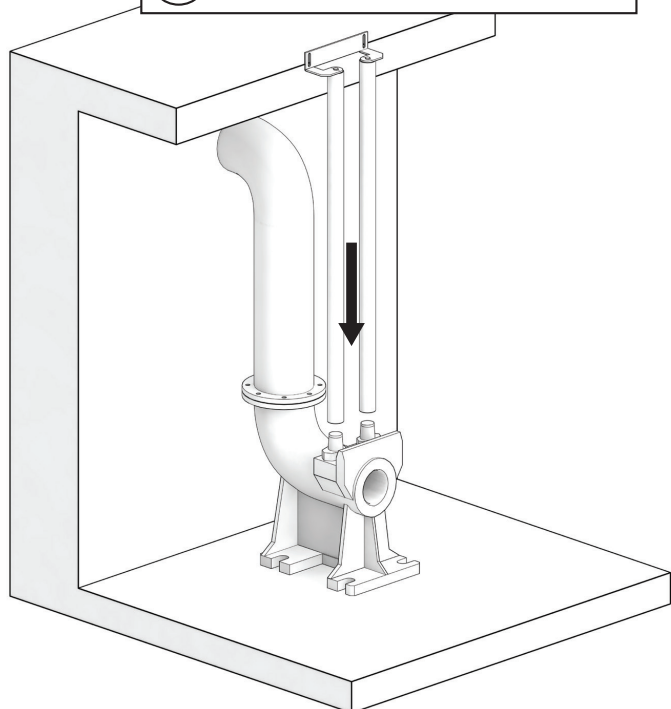

D Once the rails are fully seated, bolt the upper bracket in place so that they are secure.

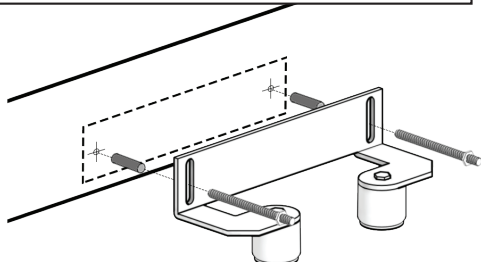

PUMP INSTALLATION GUIDELINES

The following notes are a guideline for the installation of the pumps and electrical connections. We recommend that the installation is supervised by a qualified engineer.

- The float switch counterweight (if applicable) should be set in position as per the accompanying instructions, roughly 100mm along the cable from the float.
- Suspend the float switches by their cables from the float bracket at the top of the chamber, mark the cable ends for easy identification.
- The float switch levels should be adjusted to suit the size of your chamber. The general guideline is as follows:
 - **STOP FLOAT** - level with base of the pump motor
 - **START FLOAT** - level with the top of the pump motor
 - **STANDBY/ALARM FLOAT** - above the top of the pump
- Draw the float switch cables through the cable duct to the control panel position (do not install the control panel inside the pumping station).
- Allow enough slack for the adjustment of the float switches, easy installation and removal of the pump(s).
- Ensure that all electrical cables are secured and cannot be drawn into the pump.
- Stand the pump alongside the chamber and check that the pump impellers are free to rotate.
- Connect the pump and float switches to the control panel terminals using the wiring diagram provided with the control panel.
- Switch the pump controls to manual to check for correct pump rotation. The pump body will 'kick' in the opposite direction to the pump rotation. If rotation is incorrect on a three phase (400v) installation, reverse any two phase wires in the control panel.
- Using the lifting chains provided, lower the pump(s) down the guide rail(s) and into position on the pedestal(s) at the base of the chamber.
- Attach the free end of the lifting chain to the top of the chamber.
- Switch the pump controls to auto and check the operation of the float switches is correct.

ELECTRICAL INSTALLATION GUIDELINES

- The pump control panel should be mounted indoors on a wall or vertical surface, or if situated outdoors it should be placed inside a dry weatherproof kiosk.
- The pump power supply and float cabling should be drawn back to your control panel position through the underground cable duct. The cabling should not be cleated to surfaces but should be tidied by cable ties for easy removal for maintenance at a later date.
- The float switch cables are to be connected using only two of the cable cores, the colour coding can be found inside the instructions manual provided with the float(s). The core that isn't used should be cut off and isolated. It is also advisable to mark each cable before drawing it through the duct to aid in easy identification when connecting to the control panel.
- The mains power supply is to be connected into the control panel through a cable gland as indicated on the wiring diagram provided inside the control panel, connecting the earth lead to the main earth terminal.

WIRING CONNECTIONS SHOULD ALWAYS BE MADE BY A QUALIFIED ELECTRICIAN

MECHANICAL & ELECTRICAL SETUP GUIDELINES

- Only two cores of the float switch cable are used (check the packaging/instructions with the float switch to see which colours should be used for emptying). In this condition, a contact closes in the float switch when raised.
- The float switch for pump operation needs to hang no longer than halfway down the pump, and below the inlet level. The pump must not 'run dry' before the float switch reaches its 'off position'.
- The alarm float switch needs to activate above the pumps float switch level and below the inlet level.
- The pump lifting chain should be attached to the handle using the shackle provided so you're able to lift the pump up without draining the tank. The other end will need to be attached at the top of the tank.

Single Pump

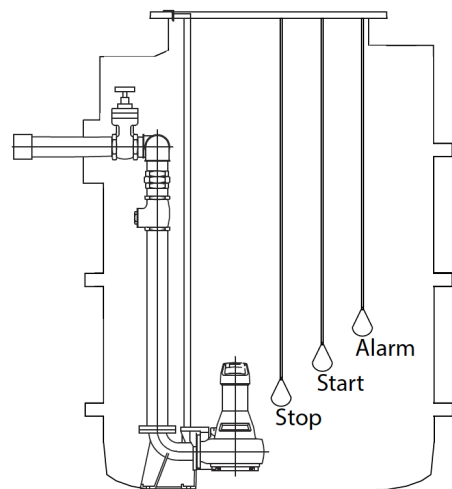
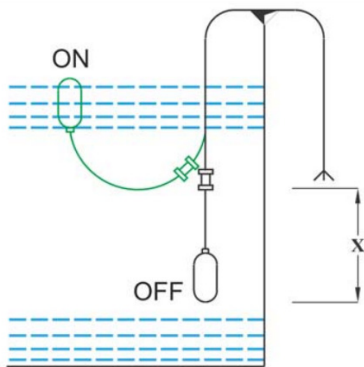

Twin Pumps

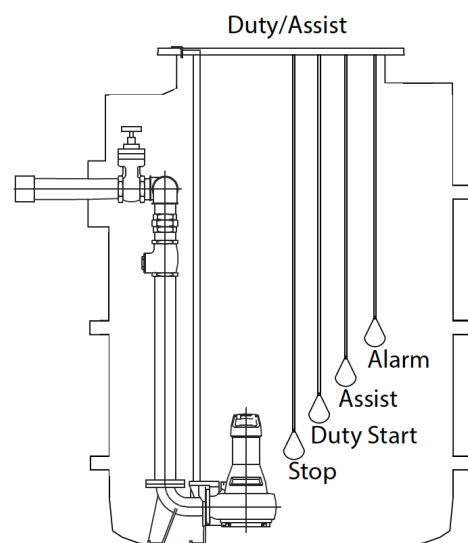
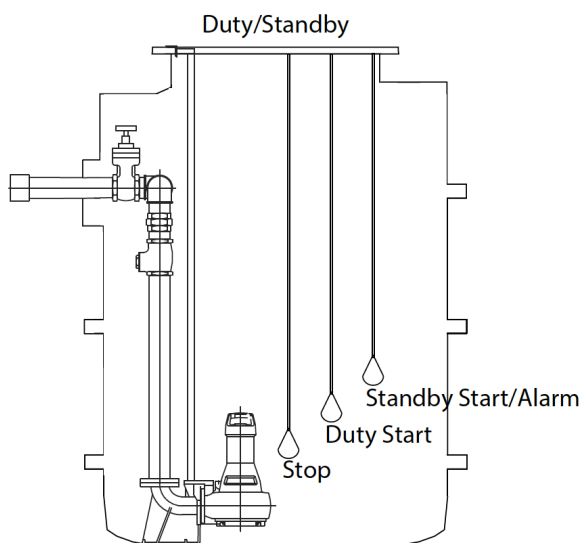

OPERATING GUIDELINES

Before filling the sump you should first check that the system is operating correctly:

1. Switch the control panel to AUTO
2. Hold the STOP level floatswitch in the UP position (Nothing should happen)
3. Hold the START level floatswitch in the UP position (Pump should start)
4. Lower the START level floatswitch (Pump should continue to run)
5. Lower the STOP level floatswitch (Pump should stop)

CAUTION: MANUAL OPERATION

The pump(s) can be set to run continuously by setting the control panel selector to manual. This setting is for maintenance and testing purposes only and should not be left on unattended. You should take care to ensure that the pumps aren't allowed to run dry for any extended period of time.

AUTOMATIC OPERATION

The packaged pumping station has a fully automatic operation and once setup it should need no further adjustment. The working parts of the pumping chamber comprise of the pump(s), the level regulating float switches and control panel.

BEFORE SWITCHING ON

- The float switches should be set at the levels shown in the installation instructions. The pump(s) should be fully lowered down the guiderails onto the base pedestal, or lowered to sit upright at the bottom of the tank if freestanding.
- The electrical supply should be checked that it is connected to the to the control panel, and that the cover is secured.

SWITCHING ON

- Set the pump(s) operating switch on the front of the control panel to OFF, then switch on the electrical supply at the main isolating switch.
- Turn the selector switch to AUTO (or ON). Providing sufficient water is in the chamber the pump should start. For twin pump systems only one of the pumps should run at a time.
- If there is insufficient water in the chamber the pump will not run.
- Allow water to enter the chamber until the START float switch is reached and fully tilted. The pump should now run.
- The pump will continue to run until sufficient water has left the chamber to allow the STOP float to hang vertically. Once this level has been reached the pump should stop.
- Once sufficient water has again flowed into the chamber, the above cycle will repeat. On twin pump systems the pumps will alternate each cycle to share the wear.

FAULT FINDING

The pump control panel is fitted with indicator lights to show whether the pump is running or tripped. If a tripped light is illuminated, this means that an overload has occurred and the pump has been isolated. A qualified engineer should be called to check any faults.

("Water in the chamber will not go down")

1. There is insufficient water to fully tilt the START float switch. Add more water.
2. Inflow to the chamber is too great for the pump to cope with. Check the cause of the excessive inflow and rectify.
3. The pump is blocked. Switch the mains supply off, lift the pump from the chamber and remove the blockage.
4. Outlet pipe is blocked. Call an engineer.
5. Electrical supply has failed. Check mains supply and setting of control panel switches.

("Water goes down but pump keeps running")

1. The STOP level float switch is set too low. Check the setting level and adjust if necessary.
2. The pump selector switch is set to MANUAL. Set switch to AUTO (for control panels with AUTO – OFF – MANUAL switches only)

ROUTINE MAINTENANCE

No routine maintenance is necessary on the pump itself, as the motor bearings are generally permanently lubricated. It is however recommended that the pump(s) are checked every six to twelve months to ensure that the oil chamber is free from contamination (as per the manufacturer's instructions), and to check the pump(s) for any blockages and to clean away any build up of fat/dirt.

1. Lift manhole cover and secure the site for Health & Safety reasons.
2. Check the pumps are operational by switching each pump to manual from AUTO.
3. Check the start level float switch is operational by lifting the float switch on each pump.
4. Check they are not contaminated with grease or other debris.
5. Check pumps are secure visually.
6. Ensure high-level alarm is operational by lifting the float switch.
7. Remove any large objects which may have found their way into the chamber.
8. Check panel is secure.
9. Ensure the pump(s) control panel is switched on and both switches are restarted on auto.
10. Close manhole and electrical cabinet.

WIRING DIAGRAM(S)

The wiring diagram(s) for the control panel or alarm unit (if applicable) are usually contained within the panel or alarm unit for the convenience of your installer. A copy of this wiring diagram should be placed with this manual for future reference.

PUMP HANDBOOK

Each pump is supplied with its own handbook, which will normally be found within the pump packaging. A copy of this handbook should be placed with this manual for future reference.

Packaged Pumping Station User Guide

By following a few simple guidelines your packaged pumping station will provide many years of reliable service.

This Automated Environmental Systems Packaged Pumping Station is designed to handle domestic waste water and sewage only.

The following items should be disposed of in a waste bin and should not be flushed down a toilet or sink and into the system:

- Glass or metal
- Nappies
- Sanitary towels, tampons or similar
- Facial wipes, antibacterial wipes or similar
- Any material such as rags or cloth
- Plastic objects
- Sand, rock, stones or other debris

Failure to follow these guidelines may invalidate your warranty, in which case any service visits and replacement pumps/parts as a result of misuse would be chargeable.

In addition to the items listed above you must never introduce the following into ANY sewer system:

- Explosives
- Flammable material
- Lubricating oil or grease
- Strong chemicals
- Petrol, diesel or similar
- Cooking Oils or Fats

Power Failure

In the event of power failure, the system will not be able to pump wastewater and sewage out of the tank, in this instance try to minimise the use of toilets, sinks and showers/baths until electrical power is restored.