

# HGM-ST Series

## Self Priming Dirty Water/Sewage Pumps

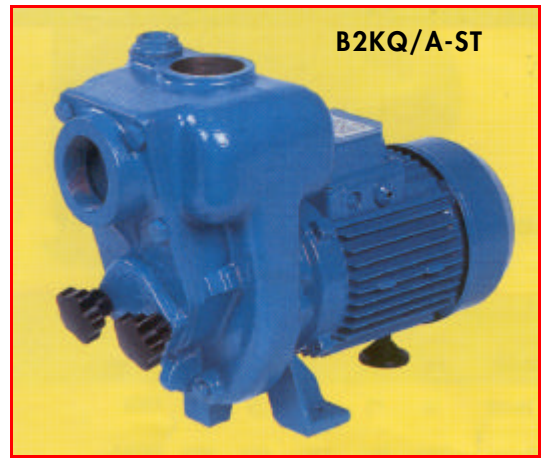

Available in 230/1/50 and 400/3/50 models, these pumps have a special three blade impeller designed for arduous dirty water and sewage type applications.

These 'Semi-Trash' pumps feature high specification mechanical seals and stainless steel wear discs. A quick access inspection door under the suction valve facilitates checking and removal of any clogging material.

An additional 4"/5.5HP model, not illustrated, is also available. It has a closed valve head of 14m and a max. flow of 2000 l/m.

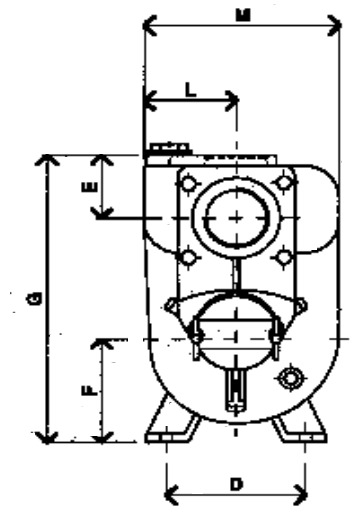
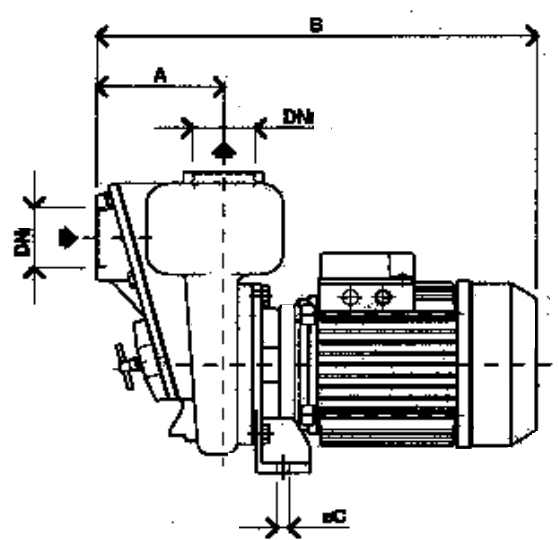

**SOLIDS HANDLING**  
 B1½ = 8.5MM  
 B2 = 15MM  
 B3 = 24MM

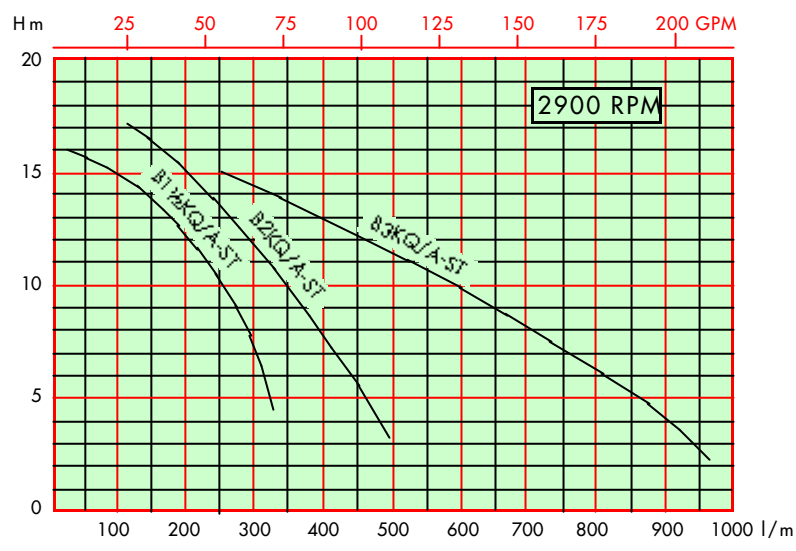

MODEL	NOMINAL		DIMENSIONS mm											WEIGHT Kg
	kW	HP	DN	A	B	diaC	D	E	F	G	L	M		
B1½KQ/A-ST	0.75	1.0	1½"	104	375	11	132	56	106	300	80	178	20	
B2KQ/A-ST	1.50	2.0	2"	122	410	11	132	64	106	300	87	184	24	
B3KQ/A-ST	2.20	3.0	3"	147	445	11	132	67	106	300	88	184	29	

© Descriptions, technical data and features contained in this leaflet are not binding. We reserve the right to make any necessary modifications without prior notice.