

## Cast Iron Foot Valve & Strainer

40mm - 150mm Flanged PN16  
200mm and above Flanged PN10

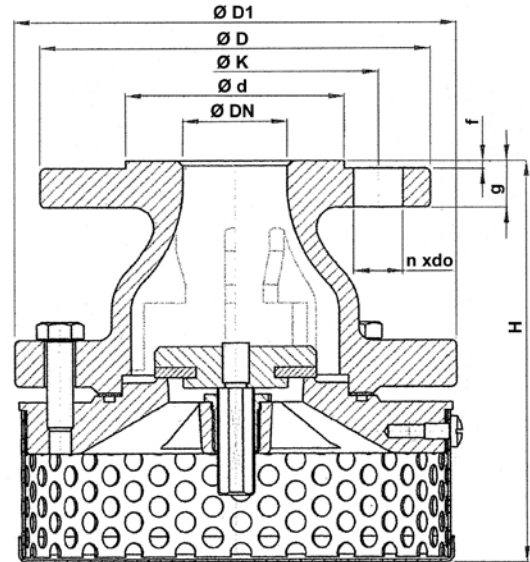

### Pressure/Temperature Ratings

Max Pressure	10 Bar
Temperature	-10°C to 90°C

### PN 10

Pressure test of the body	1.5 MPa
Pressure test of the closure	1.1 MPa
Flanges	EN 1092-2

### Material List

Body	Cast Iron – EN-GJL-250
Bonnet	Cast Iron – EN-GJL-250
Disc	Cast Iron – EN-GJL-250
Gasket	EPDM
Screen (Mesh = Ø 8mm)	X 5CrNi 18-10 Stainless Steel (AISI 304)

### Specifications

DN	D1	D	d	K	g	f	do	n	H	Weight
	mm							-	mm	Kg
40	170	150	84	110	18	3	19	4	155	8.5
50	180	165	99	125	20	3	19	4	175	9.5
65	200	185	118	145	20	3	19	4	215	12.5
80	240	200	132	160	22	3	19	8	265	18.0
100	270	220	156	180	22	3	19	8	315	26.0
125	310	250	184	210	24	3	19	8	335	32.5
150	360	285	211	240	24	3	23	8	415	43.0
200	440	340	266	295	26	3	23	8	500	74.0
250	520	395	319	350	28	3	23	12	625	107.0
300	570	445	370	400	28	4	23	12	785	150.0