

"500KG WLL Surface Mounted Davit Socket "

Finish Ref; Galvanised

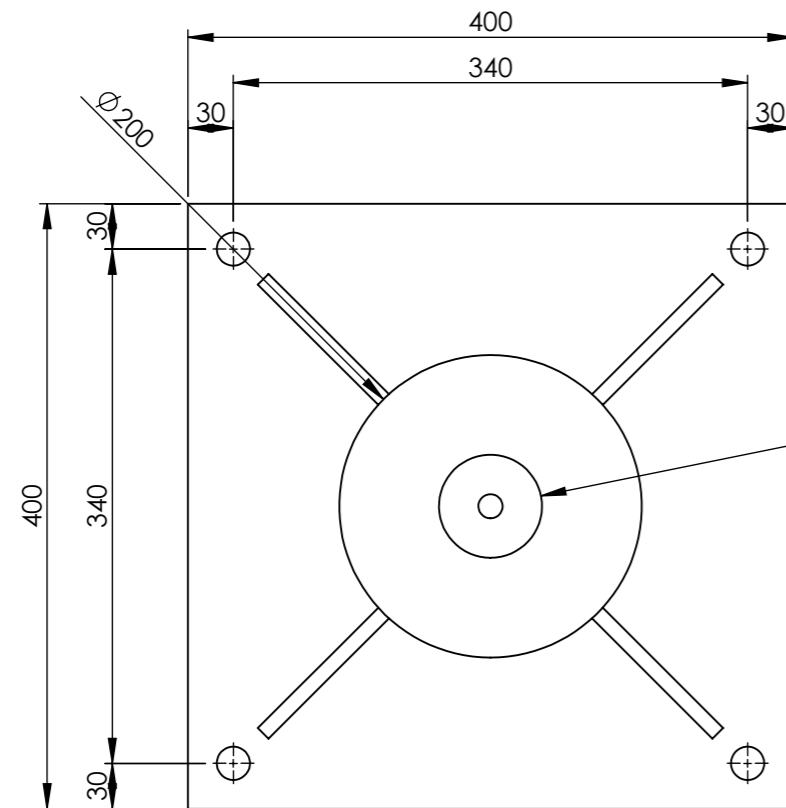

Plan View

Ø 68.10mm
Hole to accept 65mm Pin

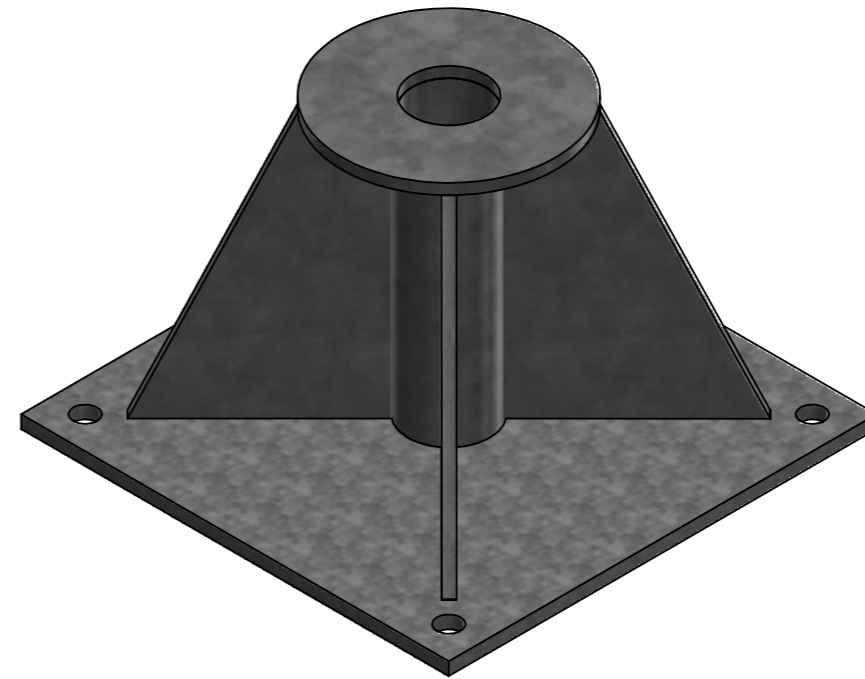

Isometric View

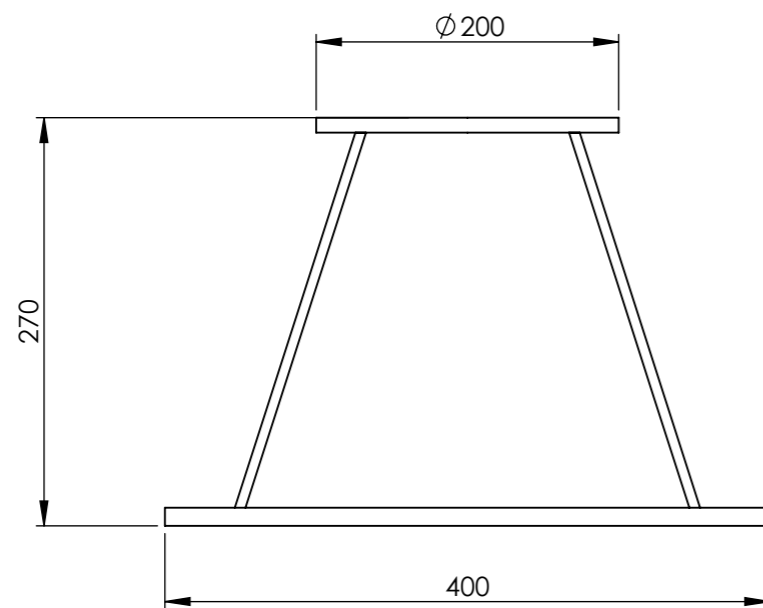

Front Elevation

General Notes / Revisions

- Mild Steel construction with a galvanised finish to BSEN 1461
- 4 qty fixing holes to accept M20 fixings
- Can be mounted directly to concrete or steel work
- Cover plate can be supplied as an extra if required

This drawing remains the property of T Allen Engineering Services Ltd and may not be copied or distributed, wholly or partially, without express permission in writing. If in doubt, ask. Unless otherwise stated, the structural integrity of the supporting substrate or superstructure should be ascertained by the customer. T Allen Engineering Services Ltd takes no responsibility

DO NOT SCALE OFF THIS DRAWING

Drawing No.	TAE-101-01		
Description	500KG WLL Davit Socket		
Revision	A		
Drawn By	D.Johnson		
Scale	1:5 @ A3	Sheet	1 of 1
Date	23/02/2017		

